

Study Unit

Four-Stroke Internal-Combustion Engines

By

Ed Abdo

About the Author

Edward Abdo has been actively involved in the motorcycle and ATV industry for over 25 years. He received factory training from Honda, Kawasaki, Suzuki, and Yamaha training schools. He has worked as a motorcycle technician, service manager, and Service/Parts department director.

After being a chief instructor for several years, Ed is now the Curriculum Development Manager for the Motorcycle Mechanics Institute in Phoenix, Arizona. He is also a contract instructor and administrator for American Honda's Motorcycle Service Education Department.

Preview

In the previous study unit you learned about the various motorcycle and ATV engine configurations. Now we'll focus on how motorcycle and ATV engines operate. We'll begin by discussing certain physical laws that pertain to engines. Next we'll describe the theory of operation for a basic internal-combustion engine. After you understand basic engine operation, we'll focus on the four-stroke engine. We'll discuss the basic components used in a four-stroke engine and then take an in-depth look at how the four-stroke engine operates.

When you complete this study unit, you'll be able to

- Explain the physical laws associated with motorcycle and ATV engines
- Describe the operation of a basic internal-combustion engine
- Explain how fuel and air are used to make an engine operate
- Identify the component parts used in a four-stroke engine
- Describe the theory of operation for a four-stroke engine

Contents

0330 INTRODUCTION	1
Matter	
Viscosity	
Boyle's Law	
Pressure Differences	
Momentum	
Laws of Motion	
Energy	
BASIC INTERNAL-COMBUSTION ENGINE OPERATION	5
Types of Combustion Engines	
Basic Construction of the Internal-Combustion Engine	
Methods of Internal Combustion	
Results of Combustion	
Internal-Combustion Engine Operation	
BASIC FOUR-STROKE ENGINE COMPONENTS	11
Four-Stroke Engine Cylinder Heads	
Four-Stroke Engine Camshafts	
Valve Train	
Four-Stroke Engine Cylinders	
Crankshafts	
Multicylinder Crankshafts	
Connecting Rods	
Crankcases	
FOUR-STROKE ENGINE THEORY OF OPERATION	32
Valve Operation	
Carburetor	
The Intake Stroke	
The Compression Stroke	
The Power Stroke	
The Exhaust Stroke	
ROAD TEST ANSWERS	37
EXAMINATION	39

Four-Stroke Internal-Combustion Engines

INTRODUCTION

As you've previously learned, there are two basic types of gasoline engines used in today's motorcycles and ATVs: the two-stroke engine and the four-stroke engine. The engine type is determined by the number of piston strokes needed to complete one full engine cycle.

One full engine cycle consists of four stages of operation: intake, compression, power, and exhaust. The two-stroke engine takes only two piston strokes to complete the cycle. The four-stroke engine takes four piston strokes to complete the cycle. However, both two-stroke and four-stroke engines are similar in that they both change heat energy into mechanical energy which is used to power the motorcycle or ATV.

Before we go into detail on how engines operate, it's important that you understand certain terms and principles related to gasoline engines and the combustion process.

Matter

Matter can be described as any substance that occupies space and has weight. Matter can't be created or destroyed but can be changed from one form to another by a chemical or physical process. An example of matter changing from one form to another is a block of ice. The ice turns to water if not kept at a freezing temperature. Also, if enough heat is applied, the water can be changed to steam.

Matter can be in the form of a solid, liquid, or gas. The block of ice in the previous example is considered to be solid matter because it has three dimensions (length, width, and depth) that can be measured.

When the ice melts, it changes from a solid form into a liquid form (water). A liquid has no definite shape and conforms to the shape of the container holding it. A liquid has the ability to transmit pressure but can't be compressed. Another interesting fact about a liquid is that it won't burn! The following are two terms describing liquids that relate to engine operation.

- An *atomized liquid* consists of liquid drops suspended in air. An example of an atomized liquid is an early morning fog. Because an atomized liquid is still a liquid, it won't burn.
- A *vaporized liquid* is a liquid that's converted to a gaseous state through a heating process. A vaporized liquid has the ability to burn. Vaporized liquids are used to make an engine run.

Steam is a gas or gaseous matter. Keep in mind that we aren't talking about gasoline when we talk about gas. Gasoline is a liquid. A gas has no definite shape and, like a liquid, conforms to the shape of its container. A gas can transmit pressure but is lighter than a liquid when compared in equal volumes. Unlike a liquid, a gas is highly compressible.

An excellent example of a gas is the air we breathe. Air is made up of approximately 78% nitrogen, 21% oxygen, and 1% inert or inactive gases. The oxygen in the air keeps us alive and also helps an engine run at its best.

Air density can be described as the amount of oxygen per given volume of space—or in other words, the thickness of air. The air all around us is actually compressed. At sea level the air pressure is 14.7 pounds per square inch (psi). Air density decreases as we increase altitude or when the temperature rises. When the air density decreases there are fewer oxygen molecules in the air. It's more difficult for you to work at the same level of intensity at 10,000 feet above sea level than at 1,000 feet above sea level. It's also more difficult to work at the same level of intensity on a very hot and humid day than on a cool and dry day. The same changes affect how an engine runs! As air density decreases, there are fewer oxygen molecules in the air for you and your engine to breathe.

Viscosity

A liquid will flow through a path such as a water hose. How fast a liquid flows is affected by its path of flow. For example, a liquid won't flow uphill without some sort of pressure behind it. The temperature of a liquid also affects its ability to flow. As the temperature of a liquid increases, the liquid has a tendency to get thinner. This change is known as *viscosity*. Viscosity is the measure of a liquid's resistance to flow. You'll normally see the word viscosity when referring to oil used in engines. A viscosity with a high number has a greater resistance to flow as compared to a low viscosity number.

Boyle's Law

As we stated earlier, a gas, like air, can be compressed. There's a physical law known as *Boyle's law* which states that "the product of the pressure and the volume of a given mass of gas is constant if the temperature isn't changed." Boyle's law tells us that when a gas is compressed, its temperature and pressure increase. The more a gas is compressed, the greater its temperature and pressure. Each time you decrease the volume of a gas by one half, you double the pressure.

Pressure Differences

Pressure differences result in movement of a gas from a high-pressure area to a low-pressure area, moving any matter that may be in the way along with it. High pressure always seeks low pressure. A common example of pressure differences can be seen every day in the weather around us. In engines, carburetion and the intake or induction phase take advantage of pressure differences for operation. You'll learn more about this later.

Momentum

Velocity is the speed of an object. Mass is the weight of any form of matter. *Momentum* is the driving force that's the result of motion or movement. Momentum is determined by multiplying mass (weight) times velocity. (Momentum = Mass × Velocity)

Laws of Motion

Two laws of motion concerned with understanding engine operation are the *law of inertia* and the *law of action and reaction*. The law of inertia states that anything at rest or in motion tends to remain at rest or in motion until acted upon by an outside force. The law of action and reaction states that for every action there's an equal and opposite reaction.

Energy

Energy is the ability to do work. If we have lots of energy, we can do lots of work. Energy itself can't be seen; however, the results of energy can be seen. An example is lifting a box and setting it on a table. Only the physical movement of the box can be seen.

Energy exists in many forms and can be changed from one form to another. For example, a battery changes chemical energy to electrical energy. No conversion of energy is 100% efficient. An example is your home heating system. As your heating system burns fuel, most of the heat is used to warm your home; however, some of the heat is lost up the chimney. The same is true in a motorcycle engine. Burning fuel in the engine provides the energy to move the motorcycle, but some energy is lost in friction and heat produced by the engine.

There are two types of energy:

- *Potential energy* is stored energy, such as in a charged battery or a can of gasoline.

- *Active energy* (or *kinetic energy*) is energy in use or in motion, such as when a battery is used to light a lamp or when gasoline is used to run an engine.

Road Test 1

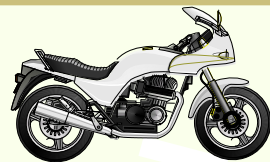

At the end of each section of *Four-Stroke Internal-Combustion Engines*, you'll be asked to check your understanding of what you've just read by completing a "Road Test." Writing the answers to these questions will help you review what you've learned so far. Please complete *Road Test 1* now.

1. If you travel from sea level to 5000 feet above sea level, what happens to the air density?

2. What does "viscosity" measure?

3. Can a liquid be compressed?

4. *True or False?* Energy can be changed from one form to another.

5. Define the "law of inertia."

6. What are the two types of energy?

7. If a gas is compressed, what happens to its temperature?

8. What type of liquid has the ability to burn?

Check your answers with those on page 37.

BASIC INTERNAL-COMBUSTION ENGINE OPERATION

Previously we discussed the basic components and operation of an engine. Now we'll discuss these topics again but in greater detail.

Motorcycle and ATV engines use a principle called *combustion* to operate. Combustion is the rapid combining of oxygen molecules with other elements. Chemical changes can result in the release of heat when elements are combined with oxygen. Heat usually speeds up any chemical changes and can act as a catalyst. A *catalyst* speeds up the chemical reaction of something without undergoing any change itself. Cold usually slows down most chemical changes. This is why engines tend to run better when warmed up than when they're first started.

Types of Combustion Engines

The engines found in all modern motorcycles and ATVs are internal-combustion engines. In an internal-combustion engine, compressed fuel and air is burned inside the engine to produce power. The internal-combustion engine produces mechanical energy by burning fuel. In a motorcycle engine, fuel is sent to the engine through an induction system, where it's burned inside to produce the power that's used to help make the engine run. In contrast, an external-combustion engine burns fuel outside of the engine. A steam engine with a boiler is an example of an external-combustion engine. We won't discuss the external-combustion engine design here because it's not relevant to motorcycle use.

Basic Construction of the Internal-Combustion Engine

Let's begin by reviewing some of the common parts in an engine (Figure 1). The *cylinder* is a hollow metal tube. The top end of the cylinder is sealed by a metal cover that's called a *cylinder head*. The cylinder head is bolted onto the top of the cylinder. The *piston* is a can-shaped metal component that can move up and down inside the cylinder. The piston is the main moving part in an engine.

The area above the piston and below the cylinder head is called the *combustion chamber*. In this chamber, a mixture of air and gasoline is compressed and burned to produce power. A *spark plug* is screwed into a threaded hole in the cylinder head. The end of the spark plug protrudes through the cylinder head and into the combustion chamber. The spark plug is used to ignite the compressed air-and-fuel mixture in the cylinder and cause it to burn. The sparking action of the spark plug is controlled by the engine's *ignition system*, which we'll discuss in detail in a later study unit.

FIGURE 1—This drawing shows a simplified cutaway view of an engine. During operation, the piston moves up and down inside the cylinder. This movement is transferred to the crankshaft through the connecting rod.

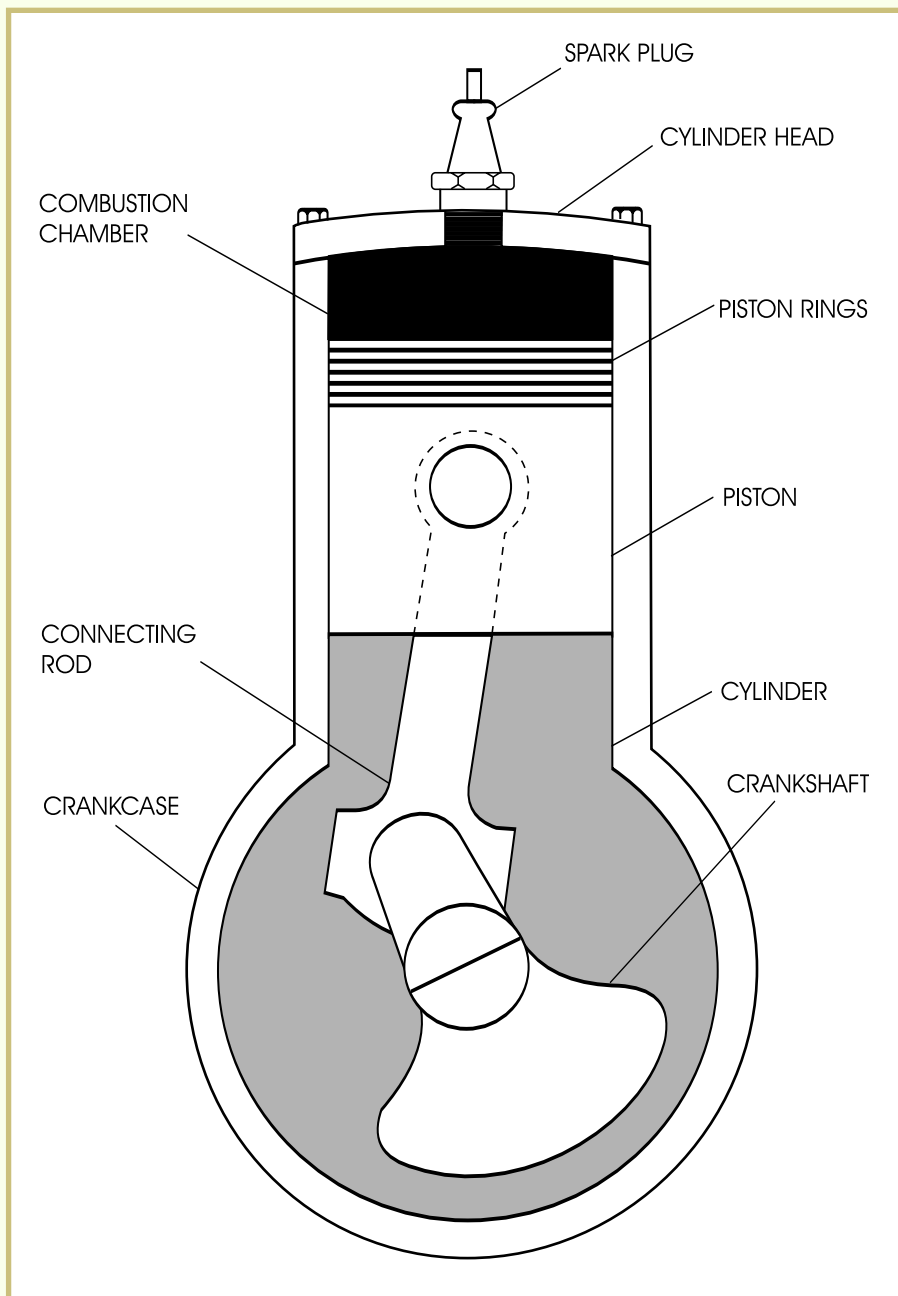

When the air-and-fuel mixture burns in the combustion chamber, it produces a small, contained explosion. The expansion of the gases due to this explosion is enough to force the piston downward into the cylinder. The bottom end of the piston is attached to a *connecting rod* and *crankshaft* assembly. When the piston is forced downward in the cylinder, the piston's downward motion is transferred to the rod and crankshaft. The rod and crankshaft then convert the up-and-down (or *reciprocating*) motion of the piston into circular or rotary motion.

Now, let's take a few minutes to review a few terms that were presented earlier. When a piston is at its highest position in the cylinder, it's said to be at *top dead center (TDC)* (Figure 2). When the piston is at its lowest position in the cylinder, it's said to be at *bottom dead center (BDC)*. The total distance that the piston moves from the top of the cylinder to the bottom of the cylinder is called the *stroke*.

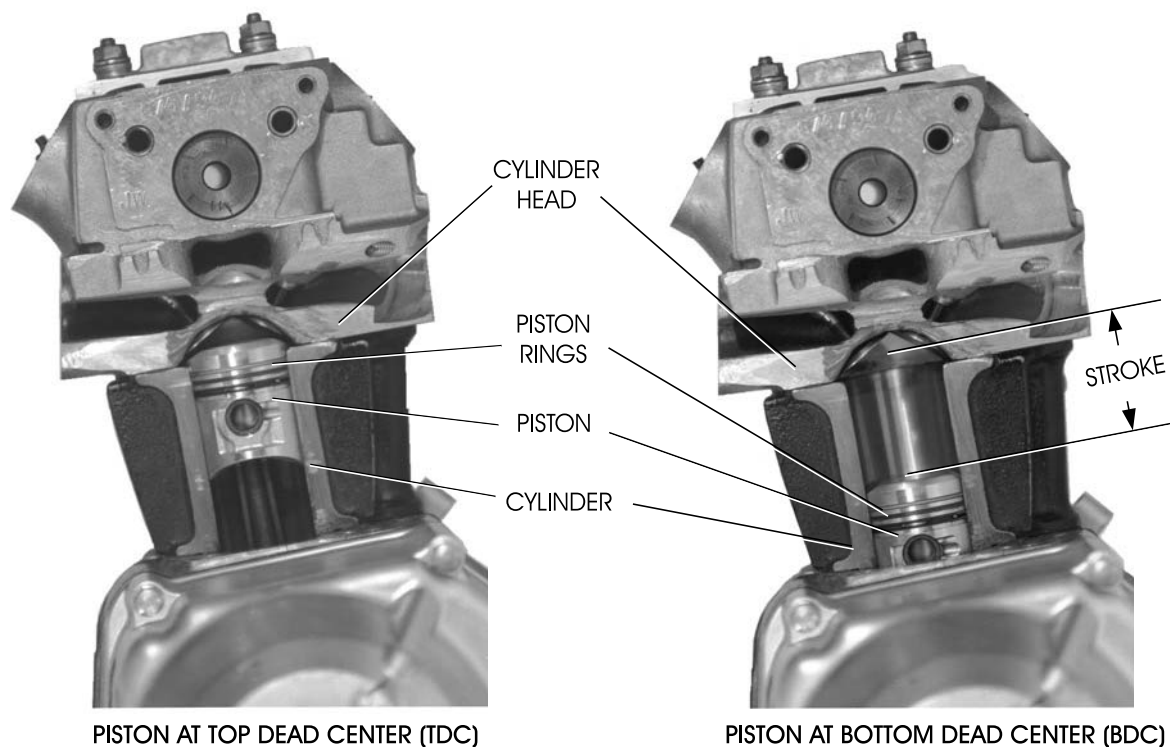

FIGURE 2—This illustration shows a cutaway view of an actual engine with the piston located at top dead center (left) and at bottom dead center (right).

The outside surface of a piston has several horizontal grooves cut into it. Each groove holds a metal ring called a piston ring. A *piston ring* is a metal ring that's split at one point and is designed to be springy. The piston rings slip over the outside of the piston and fit into the piston ring grooves. Once they're in place, the rings stick out like ridges on the surface of the piston. When a piston is inside a cylinder, the piston rings press outward against the walls of the cylinder. This helps form a tight seal between the piston and the cylinder, which is necessary for proper engine operation.

Methods of Internal Combustion

There are two methods of initiating normal combustion in an engine. The first method is *ignition*, which is the contact of a fuel with a spark. The second method is by reducing the space confining oxygen and a

combustible material, which produces heat. Motorcycle and ATV engines use a combination of these two methods. The air-and-fuel mixture is compressed into a very small space. An ignition spark begins the combustion process. As the air-and-fuel mixture burns, the hot expanding gases push the piston down. The combustion process changes potential energy in the form of the air-and-gas mixture (chemical energy) to active (kinetic) energy in the form of heat. There are three phases of combustion that occur during the power stroke of the internal-combustion engine.

Combustion Lag

The first phase of the internal-combustion engine process starts after the piston compresses the air-and-fuel mixture. The spark plug ignites a small portion of this mixture. A ball of fire spreads outward and begins to consume the remaining compressed air-and-fuel mixture. However, this ball of fire that initiates combustion doesn't immediately spread outward. Before the chain reaction spreads to the outside area of the combustion chamber, a short period of relatively slow burning takes place. This slow burning is known as *combustion lag*.

Active Combustion

The second phase of the internal-combustion engine process begins when the initial combustion lag is overcome and the chain reaction begins to spread quickly outward. A rapid temperature and pressure buildup occurs as the charge is consumed. The chain reaction of burning molecules accelerates and the chemical conversion causes heat to be released very quickly. This increase in temperature causes the pressure in the cylinder to increase. This phase is known as *active combustion*.

Post Combustion

As the piston moves down and the volume inside the cylinder increases, the pressure drops and power is absorbed by the piston. The cylinder now eliminates spent gases to prepare for the next cycle of fresh air-and-fuel mixture. All engines begin to release exhaust gases out of the cylinder well before the piston reaches bottom dead center. This is known as *post combustion*.

Results of Combustion

The heat and power generated within the combustion chamber produce work which is realized through the crankshaft and eventually through the drive system of the motorcycle or ATV. Although most four-stroke engines run at lower temperatures, cylinder head temperatures can be as high as 300–375° Fahrenheit (F). Combustion

chamber gas temperatures within the engine are known to be as high as 4000° F. This relates to cylinder pressures reaching 800–1000 pounds per square inch (psi). The heat produced expands the gases in the combustion chamber and pushes the piston towards BDC.

Chemical changes occur during combustion which convert the fuel-and-air mixture into the following chemicals:

- Carbon monoxide (CO), which results from partially burned fuel or fuel that's not completely burned during the combustion process. As mentioned in a previous study unit, remember that carbon monoxide is a colorless, odorless, poisonous, and deadly gas.
- Hydrocarbons (HC), which result from unburned or raw fuel
- Carbon dioxide (CO₂), which is the result of complete combustion
- Oxides of nitrogen (NO_x), which are forms of oxidized nitrogen resulting from extremely high combustion temperatures
- Water (H₂O), which also results from complete combustion. Believe it or not, for every gallon of fuel burned, approximately one gallon of water is produced in a vaporized form.

In the United States, the Environmental Protection Agency (EPA) has developed emission standards for street-legal motorcycles. Since 1978, motorcycles designed to be ridden on the street must comply with EPA emission standards. The two key emissions produced by motorcycles and monitored by the EPA are HC and CO. The EPA also monitors noise emissions.

Internal-Combustion Engine Operation

So far, we've looked at the basic internal-combustion process of a typical engine. Now, let's take a look at how combustion is used to allow the engine to operate. In order to work, all internal-combustion engines must do four basic things. An engine must

- Take in air and fuel
- Squeeze or compress the air-and-fuel mixture
- Ignite and burn the mixture
- Get rid of the burned gases

The engine actions we've just described are the four stages of engine operation. The proper names for these stages are *intake*, *compression*, *power*, and *exhaust*. When an engine is operating, it continually runs through these four stages, over and over again.

Intake Stage. Air that has been mixed with fuel is drawn into the cylinder.

Compression Stage. The piston rises and compresses the air-and-fuel mixture trapped inside the combustion chamber.

Power Stage. The air-and-fuel mixture is ignited. The contained explosion of the fuel pushes the piston back down the cylinder. The downward motion of the piston is transferred through the connecting rod to the crankshaft.

Exhaust Stage. The exhaust gases are released from the cylinder. The four stages then begin all over again.

One *engine cycle* is a complete run through all four stages of operation: intake, compression, power, and exhaust. Keep in mind that the four stages of operation we've described occur very quickly, and they repeat continually for as long as the engine is running. All motorcycle and ATV engines operate in these same four basic stages, and all the stages must occur in order for the engine to run properly. To understand how an engine works, one of the most important things you can do is memorize the four stages of engine operation. Once you understand these four stages, everything else we discuss about engine operation will fall into place.

Road Test 2

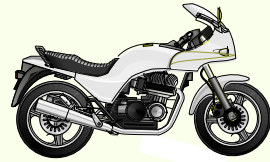

1. What are the four stages of engine operation?
 - a. Stage #1 _____
 - b. Stage #2 _____
 - c. Stage #3 _____
 - d. Stage #4 _____

2. Explain what occurs during each of the four stages of engine operation.
 - a. Stage #1 _____
 - b. Stage #2 _____
 - c. Stage #3 _____
 - d. Stage #4 _____

3. What type of combustion engine is found on all modern-day motorcycles and ATVs?

4. The piston moves up and down in the _____.

5. _____ are used to form a tight seal between the piston and the cylinder.

(Continued)

Road Test 2



6. The _____ ignites the air-and-fuel mixture in the combustion chamber.
7. _____ is a deadly gas that results from fuel that wasn't completely burned during combustion.
8. What term is used to describe the location of the piston when it's at the highest point, closest to the spark plug?

Check your answers with those on page 37.

BASIC FOUR-STROKE ENGINE COMPONENTS

Now that we've reviewed the important basics of engine operation, let's look at the four-stroke motorcycle and ATV engine components in more detail. We'll cover all the basic parts of an engine and explain how they're used. Many of these basic parts are found in both four-stroke engines and two-stroke engines. Refer to the illustrations for reference as we discuss each component. Be aware that not all engines look exactly alike. However, the illustrations provided are typical of many motorcycle and ATV four-stroke engines you'll see.

Four-Stroke Engine Cylinder Heads

Cylinder heads are constructed of aluminum alloy or cast iron (Figure 3). The four-stroke cylinder head holds the intake and exhaust valve train components and the spark plug. The cylinder head also seals the top end of the cylinder for compression of the air-and-gas fuel mixture under the spark plug to increase combustion efficiency. Holes in the cylinder head that are called *ports* provide for the air-and-fuel intake and exhaust. Cylinder heads also aid in the transfer of heat from the engine by the use of fins on air-cooled engines or by using water jackets on liquid-cooled engines.

Many modern four-stroke motorcycles and ATVs use multivalve cylinder heads. Cylinder heads may have anywhere from two valves to eight valves per cylinder. The intake valve area is usually larger than the exhaust valve area on the four-stroke engine.

FIGURE 3—This illustration shows a typical water-cooled engine cylinder head attached to the cylinder. (Copyright by American Honda Motor Co., Inc. and reprinted with permission)

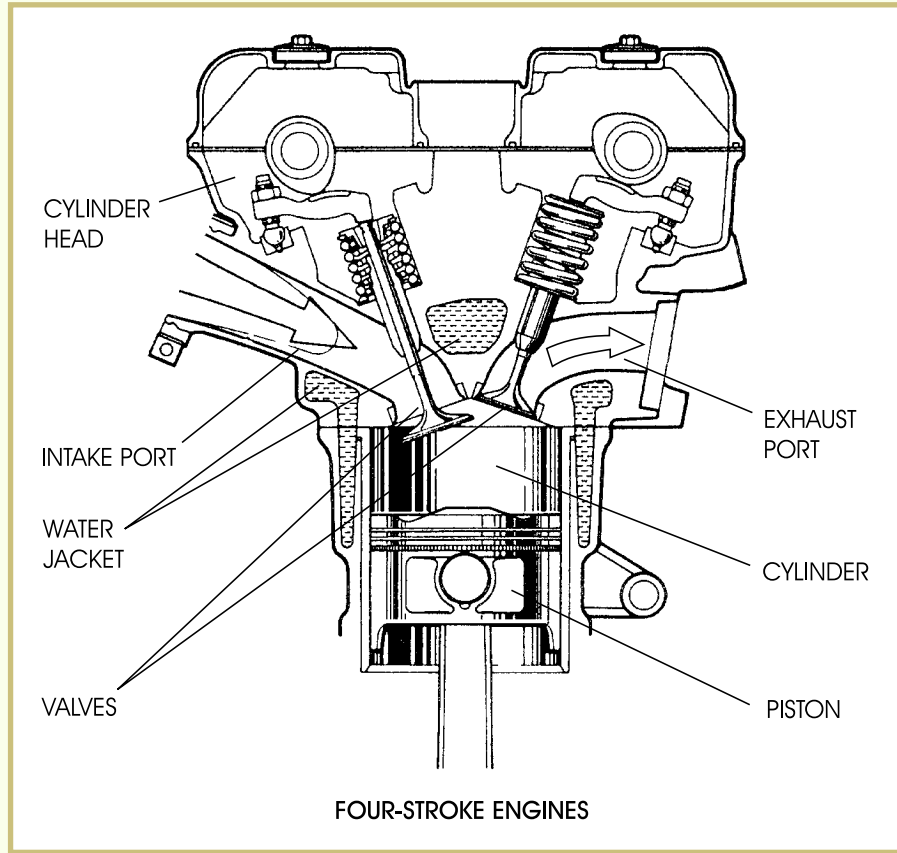

Poppet Valves

Four-stroke engines use mechanical valves called *poppet valves* to control the gases coming into and going out of the engine. Poppet valves, which are tulip-shaped, open and close every other crankshaft revolution. The poppet valve may be made from stainless steel, carbon steel, or titanium. The various parts of the valve are shown in [Figure 4](#).

FIGURE 4—The Parts of a Valve

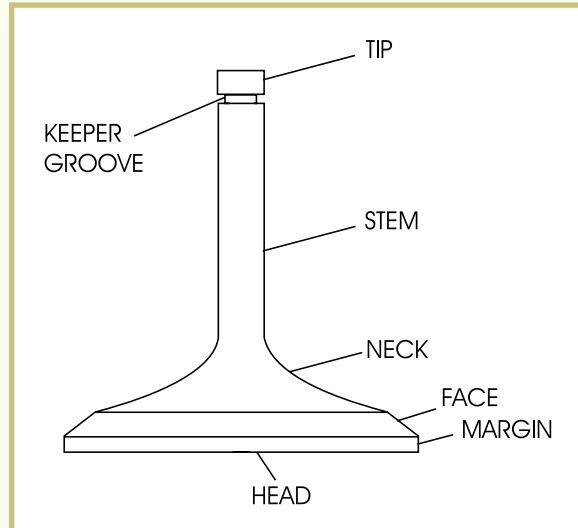

- The *valve tip* is the part of the valve that rides against the valve-opening device. Most valve tips are stellite-plated for wear. Stellite is an extremely hard metal alloy that resists wear and won't soften at high temperatures.
- The *keeper groove* is where keepers lock the valve and spring retainer in place.
- The *valve stem* is the thrust surface for the valve guide and is considered to be a major wear area. If the stem is worn, excessive amounts of oil can pass between the stem and guide into the combustion chamber. If oil leaks into the combustion chamber, smoke appears in the exhaust.
- The *valve neck* is the sloped area of the valve that connects the valve stem to the valve head.
- The *valve face* mates with the cylinder head valve seat to seal gases in the combustion chamber and aid in heat transfer. The valve face is often coated with stellite to reduce wear and prolong the life of the valve.
- The *margin* supports the valve face and shields the face from high combustion temperatures.
- The *valve head* is the bottom portion of the valve and forms a part of the combustion chamber.

The common wear areas of the valve are the tip, face, stem, and keeper groove.

Valve Seats

Cylinder head *valve seats* (Figure 5) are stationary in the cylinder head and are the sealing surface for the valve face. There are normally at least three angles cut into the valve seat to allow for better air-and-fuel flow into the cylinder through the valve opening.

Valve Guides

Valve guides (Figure 5) are installed in the four-stroke cylinder head. Valve guides provide a bushing surface for the valve stem.

Valve Stem Seals

Valve stem seals (Figure 6) are installed on the valve guides and are used to prevent excessive oil from entering between the inside of the valve guide and valve stem.

FIGURE 5—Valve seats and guides are located in the cylinder head. (Copyright by American Honda Motor Co., Inc. and reprinted with permission)

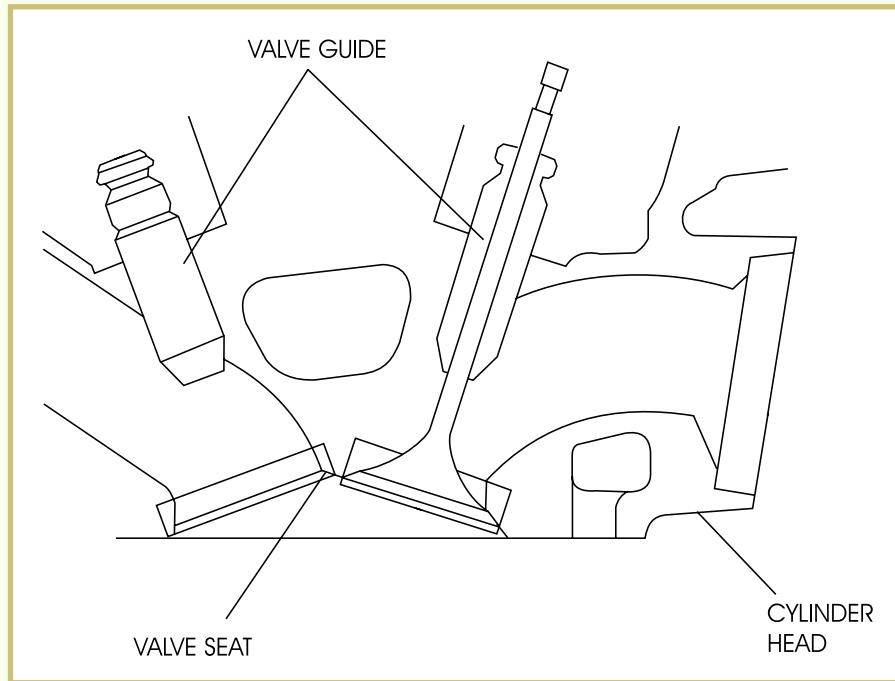

Valve-Closing Devices

Valve-closing devices keep the valve closed when required. The most common method to close a valve is with the use of coil springs (Figure 6) attached between the valve and the cylinder head. The springs are held in place with valve spring retainers and valve keepers that fit into the valve keeper grooves. There are usually two coil springs per valve to reduce the chance of valve float. Valve float is the point at

FIGURE 6—This illustration shows the valve stem and components used to close the valve.

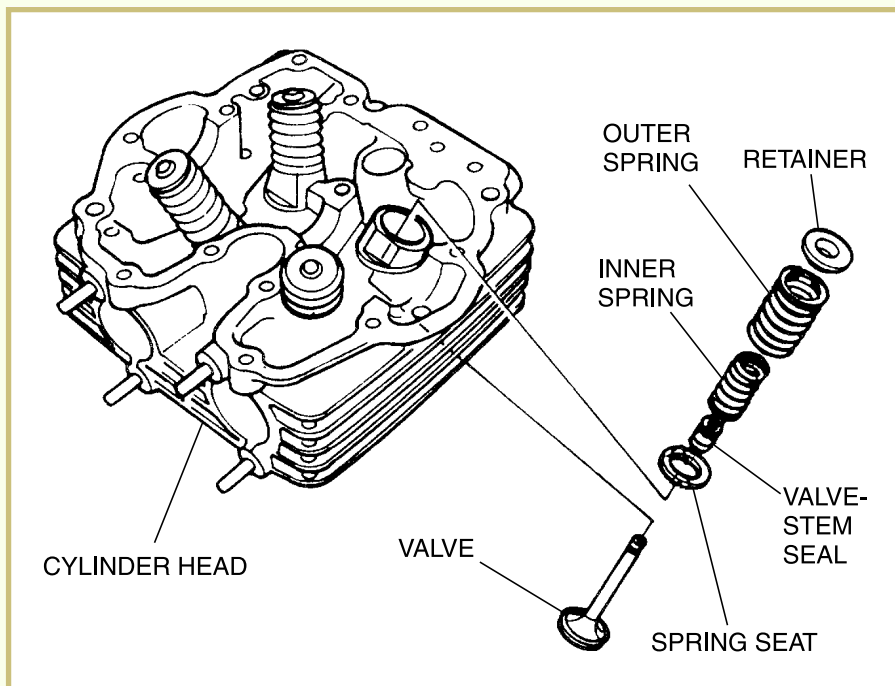

which the valve doesn't stay in constant contact with the valve train. Valve float can occur when the valve springs are weak or during excessively high engine speed. Other devices have been used in the past, such as torsion bars and hairpin springs, but aren't seen in today's modern motorcycle or ATV engines.

Valve-Opening Devices

The main *valve-opening device* is the cam follower. The *cam follower* contacts the valve tip and is used to transfer motion from the cam shaft to the valve. There are two types of valve-opening devices used on the four-stroke motorcycle and ATV.

One type of valve-opening device is a *rocker arm*. The rocker arm is a lever that can gain a mechanical advantage and change the direction of force applied to it (Figure 7). The rocker arm can also open more than one valve. There are various rocker arm designs used on the four-stroke engine but they all perform the same function. A disadvantage of rocker arms is that they create side loads on valve stems and guides which can cause excessive wear.

FIGURE 7—This illustration shows a simple diagram of a rocker arm.

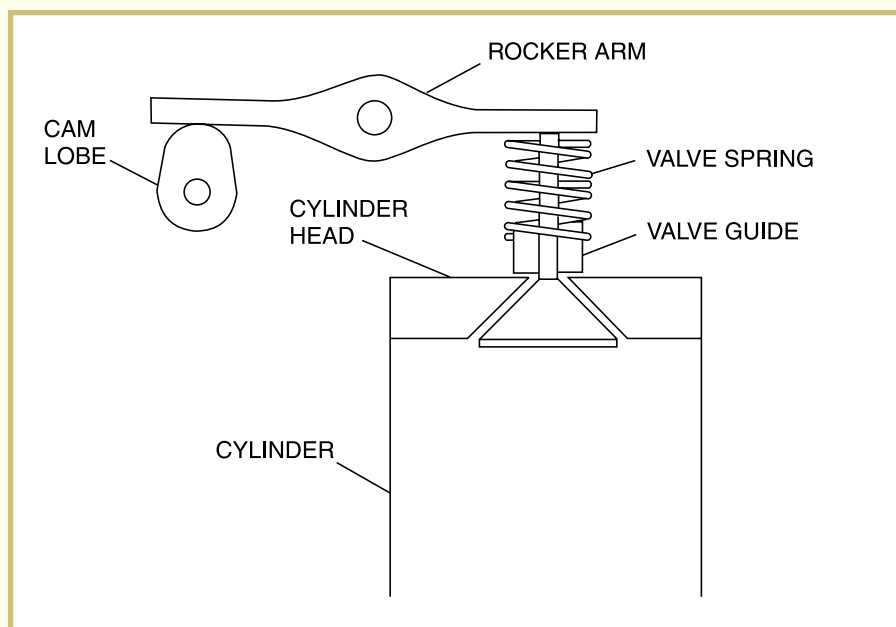

The second type of valve-opening device is the *shim and bucket*. The bucket is located above the valve in the cylinder head. The shim may be located either above or below the bucket. This type of valve-opening device doesn't create side loads and allows for a lighter mass in the valve train because it has fewer moving parts.

Valve clearance or lash (Figure 8) is necessary to allow for heat expansion, oil clearance, and for proper sealing of the valve. Too little clearance causes improper sealing of the valve and excessive heat. Too much clearance causes excessive wear and noise.

FIGURE 8—This illustration shows valve clearance with a screw and lock nut for adjustment. Valve clearance is important to allow for heat expansion, oil clearance, and proper sealing of the valve. (Copyright by American Honda Motor Co., Inc. and reprinted with permission)

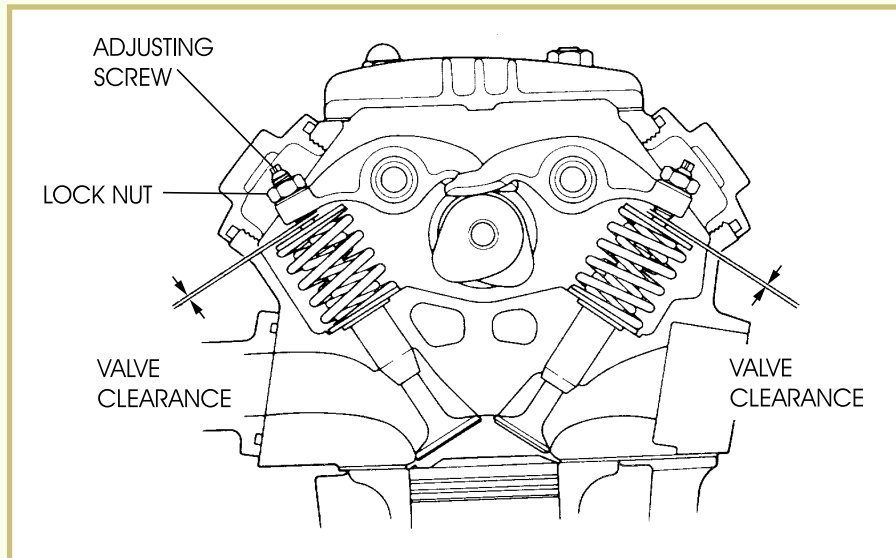

There are different types of valve lash adjusters used to adjust valves on motorcycles and ATVs. Three of the most popular types are as follows:

- The *screw and lock nut* (Figure 8) uses a screw that can be turned in or out to change the clearance. After the adjustment has been made, a lock nut holds the screw in place. The screw and lock nut may be located on the rocker arm, on a push rod, or on a valve lifter.
- The *shim and bucket* is used for both a valve-opening device and an adjustment device. The shims are used to adjust the valves for proper clearances. Clearances are changed by changing the size of the shim. The two popular types of shim-and-bucket adjusters are shim-over-bucket, where the shim rests on top of the bucket and shim-under-bucket, where the shim rests under the bucket (Figure 9). You must remove the camshaft to replace a shim with this design.
- *Hydraulic valve lash adjusters* (Figure 10) automatically adjust for the proper clearance by using oil pressure to maintain zero lash at all engine temperatures and speeds.

FIGURE 9—This illustration shows the location of the shims in the shim-over-bucket design and the shim-under-bucket design valve adjustments. (Copyright by American Honda Motor Co., Inc. and reprinted with permission)

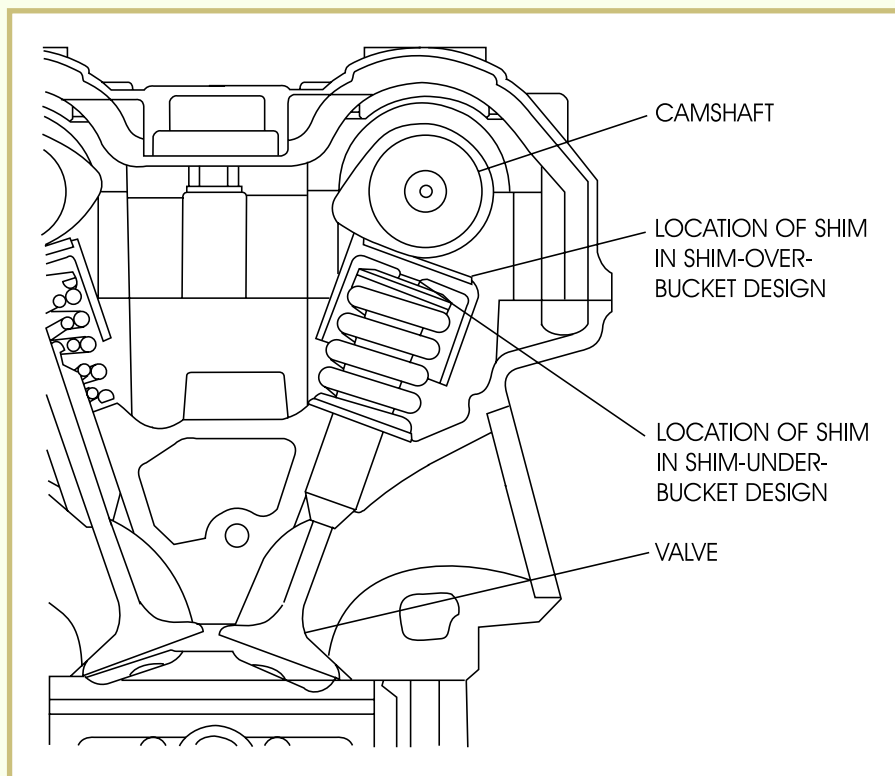
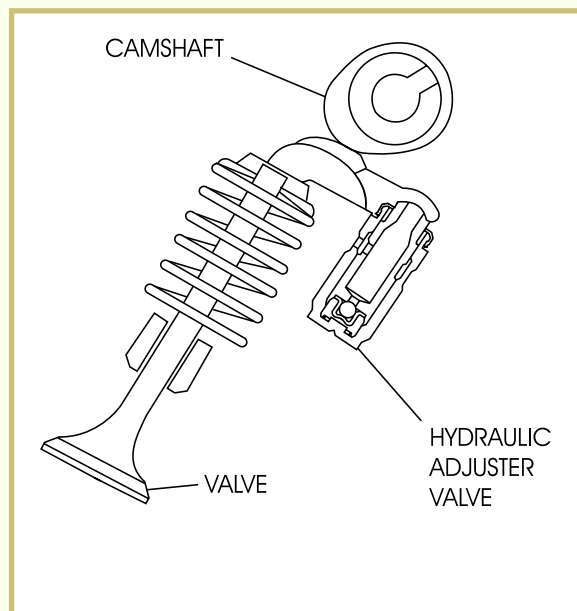

FIGURE 10—This illustration shows a hydraulic adjuster valve which automatically adjusts for proper valve clearance. (Courtesy of American Suzuki Motor Corporation)



Four-Stroke Engine Camshafts

The purpose of the *camshaft* (also known as the *cam*) is to change rotary motion to reciprocating motion. The camshaft is also a mechanical valve timer that controls

- When to open
- How fast to open
- How far to open
- How long to stay open
- When to close
- How fast to close
- How long to stay closed

There are various parts of a camshaft that are important to its ability to function properly in the four-stroke motorcycle and ATV engine (Figure 11).

FIGURE 11—The Parts of a Camshaft

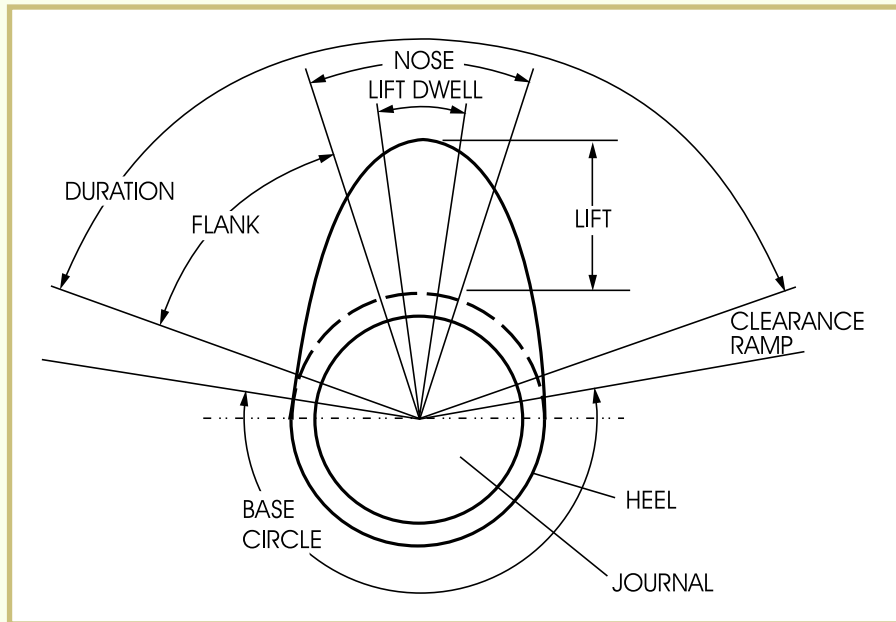

- The *base circle* is the area of the camshaft that forms a constant radius from the centerline of the journal to the heel. The *heel* is the part of the cam that allows the valve to seat onto the cylinder head and seal off the combustion chamber.
- *Clearance ramps* take up the valve clearance and open and close the valve. These ramps act similarly to a shock absorber and are used to gently (relatively speaking) open and close the valve.
- The *flanks* of the cam determine and control the acceleration of the opening and closing of the valve.

- The *nose* is the area of the camshaft where the valve is opened the greatest distance from the cylinder head area; it controls lift dwell. *Lift dwell* is the amount of time in crankshaft degrees that the valve stays open at maximum lift.
- *Camshaft lift* is a measure of the difference between the base circle and the nose. Depending on the type of engine, this may or may not translate into the *actual valve lift*, which is the distance that the valve actually moves away from the cylinder head.
- The *duration* of a camshaft is a measure of how long the valve is held open. Duration is measured in crankshaft degrees.

Most camshafts have what's known as valve overlap built into them. Valve overlap occurs between the exhaust and intake strokes. *Valve overlap* is the time that both valves are open simultaneously and is measured in crankshaft degrees. High-performance engines generally have more valve overlap to allow for more air-and-fuel mixture to be packed into the cylinder combustion chamber. While this allows for higher peak power, an engine with a camshaft exceeding 30 degrees of valve overlap will lack efficiency in the low- and mid-range power areas of the engine.

Camshaft Drives

The camshaft rotates at one-half the speed of the crankshaft to properly time the intake and exhaust valves with the piston as it moves up and down the cylinder. There are three methods used to drive a camshaft on a four-stroke motorcycle or ATV engine.

- The *chain type* of camshaft drive normally operates in an oil bath to maintain lubrication (Figure 12).
- The *gear type* of camshaft drive also operates in an oil bath for lubrication and to reduce noise (Figure 13).
- The *toothed-belt type* of camshaft drive runs on pulleys with teeth. This system is very quiet and requires no lubrication; however, proper alignment and tension are critical (Figure 14).

Camshaft Drive Tensioners

The purpose of a *camshaft drive tensioner* is to keep the proper tension on the cam chain or cam belt (Figures 12 and 14). There are manual tensioners that require adjustment and automatic tensioners which automatically adjust the tension while the engine is running.

FIGURE 12—Example of a Chain-Driven Camshaft

(Copyright by American Honda Motor Co., Inc. and reprinted with permission)

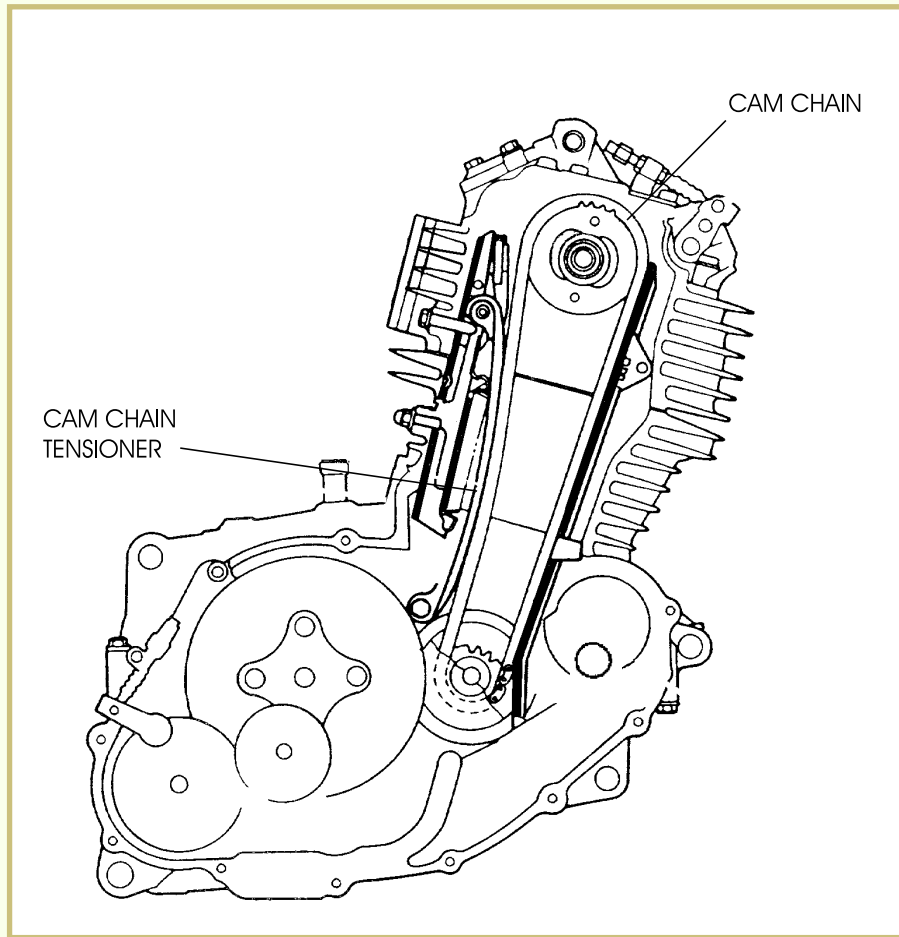

Valve Train

The *valve train* consists of the valve components in the cylinder head and the valve drive components previously discussed. These components are used to provide the different types of valve trains found on four-stroke motorcycle and ATV engines.

- A pushrod with rocker arm is shown in [Figure 15A](#).
- A single overhead cam with rocker arms is shown in [Figure 15B](#).
- A dual overhead cam with rocker arms is shown in [Figure 15C](#).
- A dual overhead cam with shim and buckets is shown in [Figure 15D](#).

FIGURE 13—Example of a Gear-Driven Camshaft (Copyright by American Honda Motor Co., Inc. and reprinted with permission)

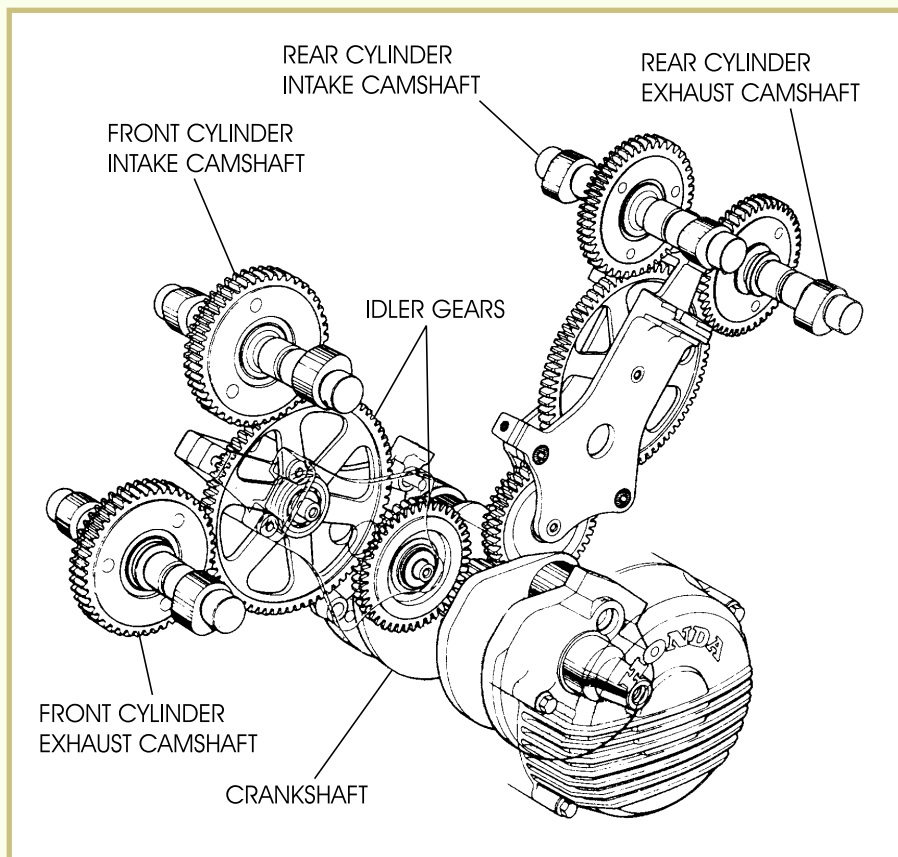
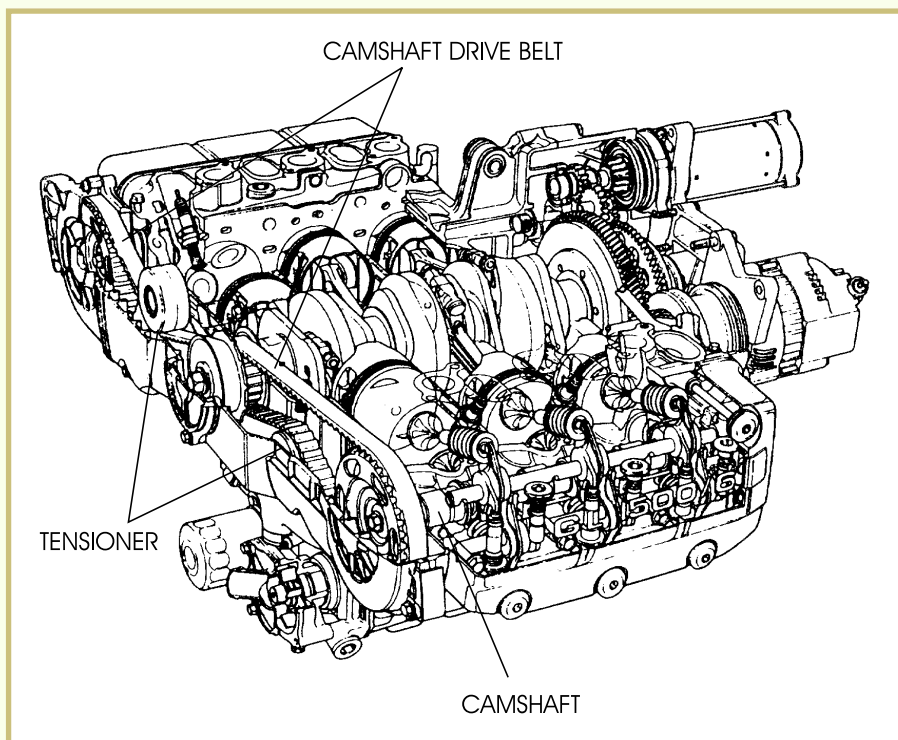
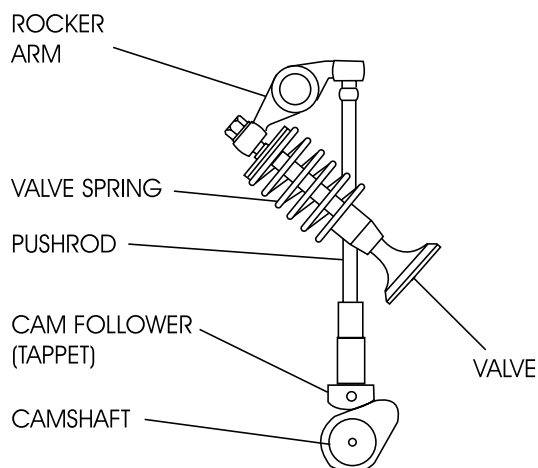
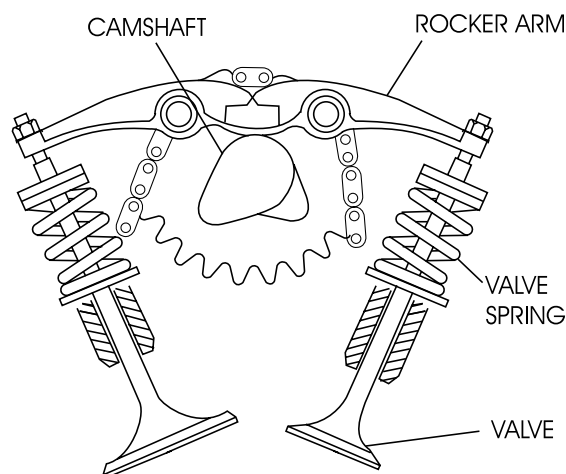

FIGURE 14—Example of a Belt-Driven Camshaft (Copyright by American Honda Motor Co., Inc. and reprinted with permission)





(A) PUSHROD WITH ROCKER ARM



(B) SINGLE OVERHEAD CAM WITH ROCKER ARMS

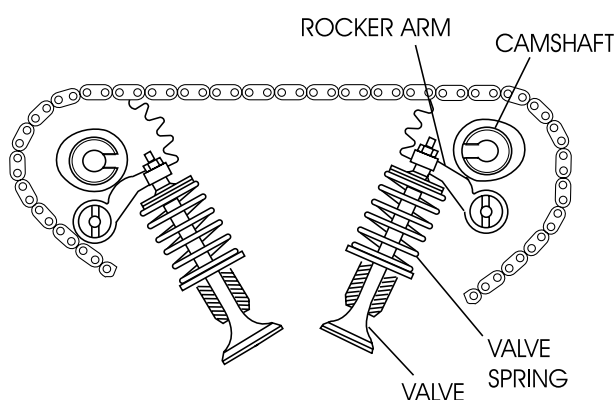

(C) DUAL OVERHEAD CAM WITH ROCKER ARMS

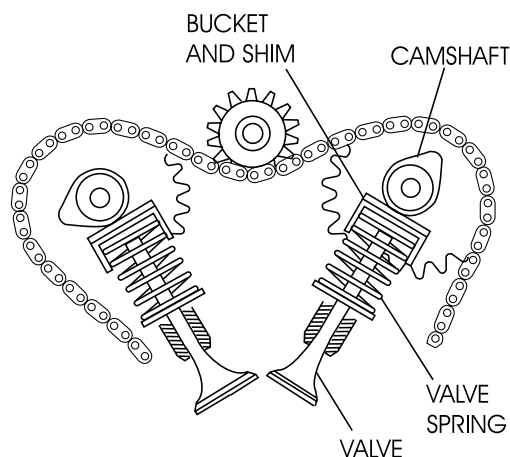

(D) DUAL OVERHEAD CAM WITH SHIM AND BUCKETS

FIGURE 15—Types of Valve Trains (Courtesy of American Suzuki Motor Corporation)

Four-Stroke Engine Cylinders

The purpose of the four-stroke engine cylinder is to guide the piston as it travels up and down. The cylinder helps to transfer engine heat and may be either air cooled or liquid cooled (Figure 16).

There are different types of materials used in the construction of a cylinder. Each material has its advantages and disadvantages.

FIGURE 16—This is a typical liquid-cooled cylinder. A liquid-cooled cylinder uses water jackets as opposed to the cylinder fins used on an air-cooled cylinder.

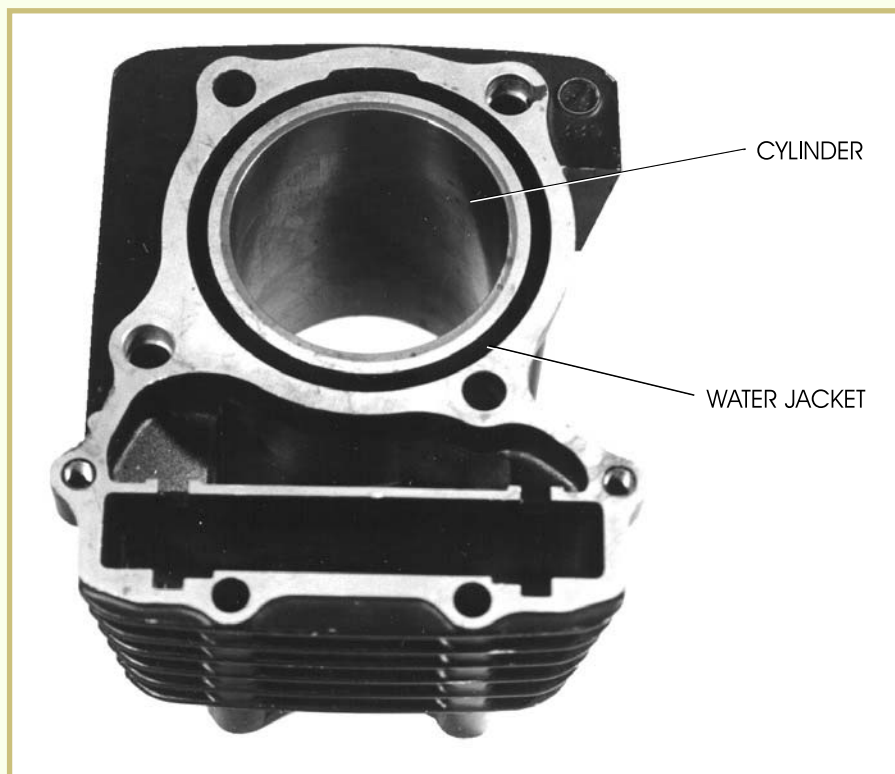

- *Cast-iron cylinders* have a one-piece design and can be fit with oversize pistons by boring to a larger size. When a cylinder is bored, material is removed from the cylinder to enlarge the hole. A larger “oversized” piston is then used in place of the previous piston. The cast-iron cylinder is inexpensive to manufacture but has poor heat transfer characteristics when compared to other materials used to construct cylinders. Cast-iron cylinders are also very heavy.
- *Aluminum cylinders* with cast-iron or steel sleeves have much better heat transfer abilities than cast-iron cylinders and are much lighter in weight. These cylinders can also be bored to a larger diameter. In most cases, the sleeve can be replaced if needed.
- *Plated-aluminum cylinders*, which are also called *Nikasil* or *composite cylinders*, have the best heat transfer characteristics of any cylinder produced today. They’re the lightest-weight cylinders available and when properly maintained are the longest-lasting cylinders. The disadvantage of plated-aluminum cylinders is that they can’t be bored to a larger diameter and therefore must be replaced when damaged. These cylinders are expensive to replace when compared to the other types of cylinders.

Cylinders have tiny scratches purposely installed into the cylinder wall called *crosshatching*. This crosshatching is created by honing the cylinder wall with a cylinder hone. The purpose of honing is to help

seat the piston rings and retain a very thin layer of oil on the cylinder walls to keep them properly lubricated.

Cylinders must be round from top to bottom to work properly. They shouldn't have any taper or out-of-roundness. We'll discuss how to measure cylinders in a future study unit.

Pistons

The purpose of the piston is to transfer power produced in the combustion chamber to the connecting rod. The piston is manufactured in a way that makes it *directional*. This makes it necessary to install the piston in the specific manner indicated in the service manual.

Pistons are tapered from top to bottom. The top of the piston is smaller than the bottom to allow for different heat expansion rates of the piston. To allow for further heat expansion, pistons are *cam ground* so they're oval in shape when cold. When the piston reaches operating temperature, it becomes round to match the cylinder.

There are two common piston-manufacturing methods: cast aluminum and forged. *Cast-aluminum pistons* are the more common. *Forged pistons* use aluminum alloy forced into a die under extreme pressures. This manufacturing method produces a stronger piston, but makes the piston more expensive.

A piston has several parts ([Figure 17](#)).

FIGURE 17—The Parts of a Typical Four-Stroke Piston

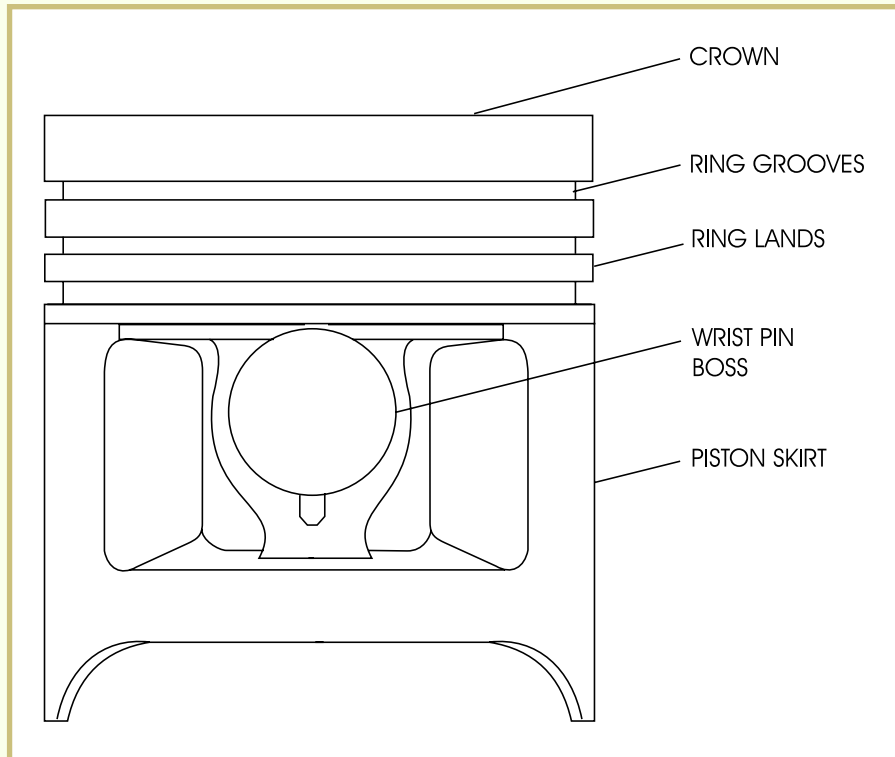

- The *crown* is the top of the piston and acts as the bottom of the combustion chamber. The crown is the hottest part of the piston, due to combustion chamber temperatures. The crown area expands more than the rest of the piston because it's hotter and has more mass. The piston crown may have a positive dome, flat top, or negative dome. There also may be notches in the crown to allow for valve relief.
- The *ring grooves* allow for installation of piston rings. The bottom ring groove of the four-stroke piston has holes or slots for oil return that help remove oil from the cylinder wall. This also helps to lubricate the wrist pin. The *piston ring lands* support the piston rings.
- The *wrist pin boss* is where the piston attaches to the small end of the connecting rod. A hardened tool-steel *wrist pin* attaches the piston to the rod. The wrist pin is normally held in place with retaining clips to prevent it from contacting the cylinder wall.
- The *piston skirt* is the load-bearing surface of the piston. The piston skirt contacts the cylinder wall and is the primary wiping surface for the cylinder wall. The largest diameter of the piston is usually at or close to the bottom of the skirt and 90 degrees from the wrist pin. This is where the piston is normally measured.

Piston Rings

The purpose of *piston rings* is to aid in heat transfer from the piston to the cylinder wall, seal in the combustion gases, and prevent excessive oil consumption. There are three types of piston rings used on the four-stroke piston (Figure 18).

- The *compression ring* is closest to the piston crown and is used to seal most of the combustion chamber gases. The compression ring is usually made of cast iron and may be chrome plated, teflon, or moly coated.
- The *scraper ring* is the middle ring and aids in sealing the combustion chamber gases. The scraper ring scrapes excessive oil from the cylinder wall. Like the compression ring, the scraper ring is made of cast iron, but in most cases has no coating.
- The *oil control ring* is the ring closest to the piston skirt. The oil control ring removes the oil from the cylinder walls left behind by the piston skirt.

Piston rings have an *end gap* to allow for heat expansion. The end gap is measured by using a feeler gauge after fitting the ring squarely in the cylinder (Figure 19).

FIGURE 18—Types of Piston Rings on Four-Stroke Engine Pistons (Courtesy of American Suzuki Motor Corporation)

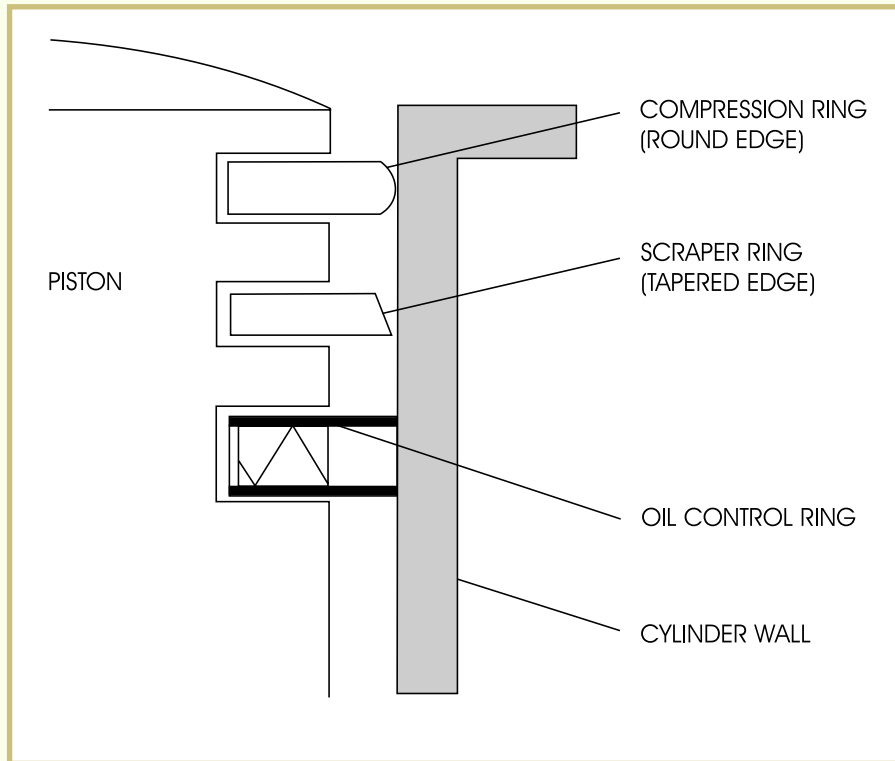
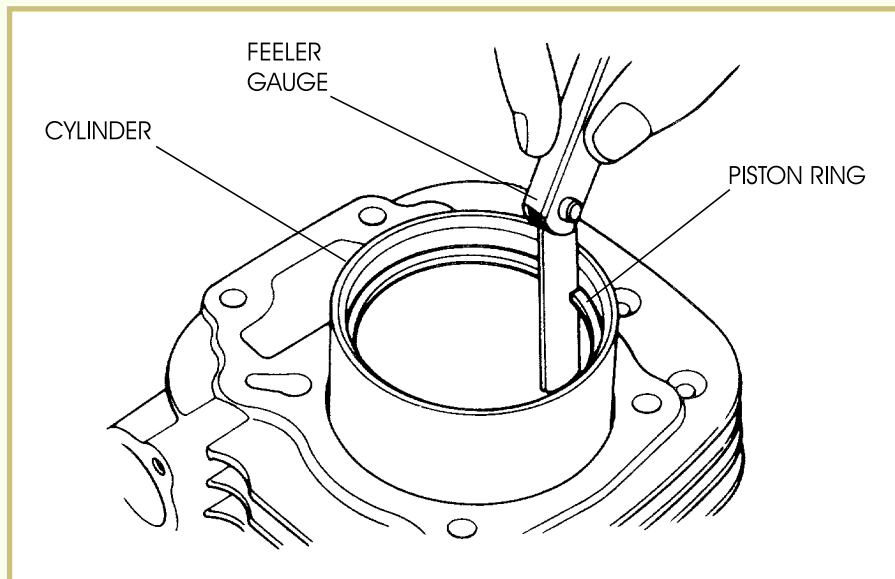

FIGURE 19—The piston ring end gap is measured using a feeler gauge. (Copyright by American Honda Motor Co., Inc. and reprinted with permission)



Crankshafts

As we discussed earlier, the purpose of a crankshaft is to change the reciprocating motion from the piston into a rotary motion. The main parts of a crankshaft include journals and counterweights ([Figure 20](#)).

Journals give bearing support. Main journals support the mass of the crankshaft and are located at the center of the rotating axis.

FIGURE 20—One-Piece Crankshaft Used on Four-Stroke Engine (Copyright by American Honda Motor Co., Inc. and reprinted with permission)

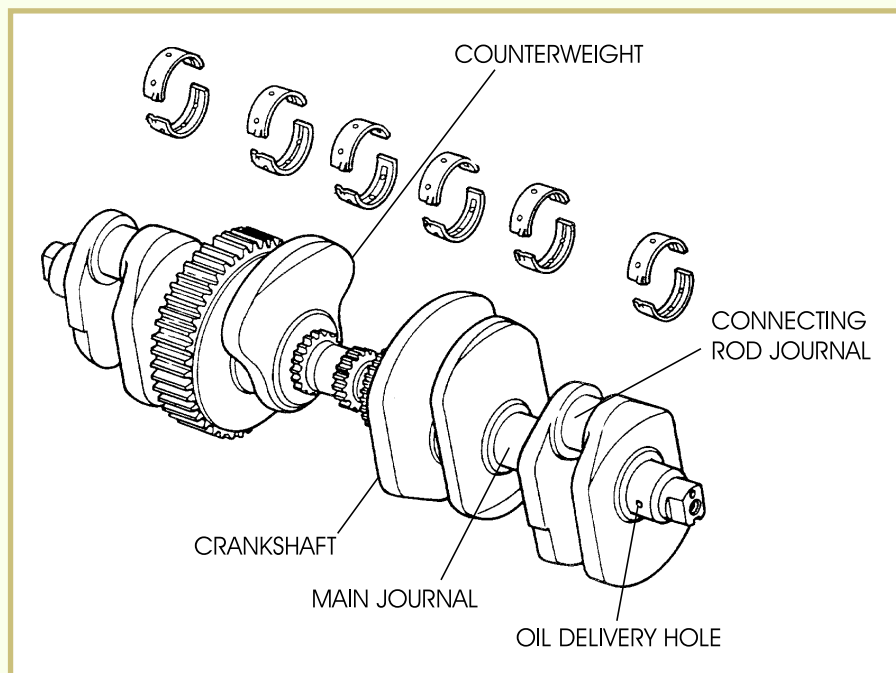

Connecting-rod journals support the connecting rods and are offset from the main journals.

Counterweights add momentum to the crankshaft. The counterweights assist in keeping the crankshaft rotating and the engine running smoothly by counterbalancing the reciprocating masses from the piston and connecting rod. Some engines use remote counterweights, which are located on a separate shaft and are chain or gear driven. Remote counterweights must be timed properly with the crankshaft.

There are two different types of crankshafts used in four-stroke engines.

- The *one-piece crankshaft* is cast or forged as one part (Figure 20). The one-piece crankshaft is the stronger in design but must be used with a multipiece connecting rod. Most one-piece crankshafts are cross-drilled for oil delivery to the connecting rod journals and use plain bearings at the main and connecting-rod journals. Most one-piece crankshafts use high oil volume and pressure to the bearings. Generally, you can't rebuild these crankshafts.
- The *multipiece crankshaft* uses crankshaft halves which are cast or forged (Figure 21). The connecting-rod journal is a pin (crank-pin) that's pressfit into the halves. A one-piece connecting rod uses a roller bearing at the connecting-rod journal. The multipiece crankshaft generally uses ball bearings on the main journals. Most multipiece crankshafts can be rebuilt. Figure 22 shows an assembled multipiece four-stroke engine crankshaft with connecting rod.

FIGURE 21—Multipiece Crankshaft Used on Four-Stroke Engine

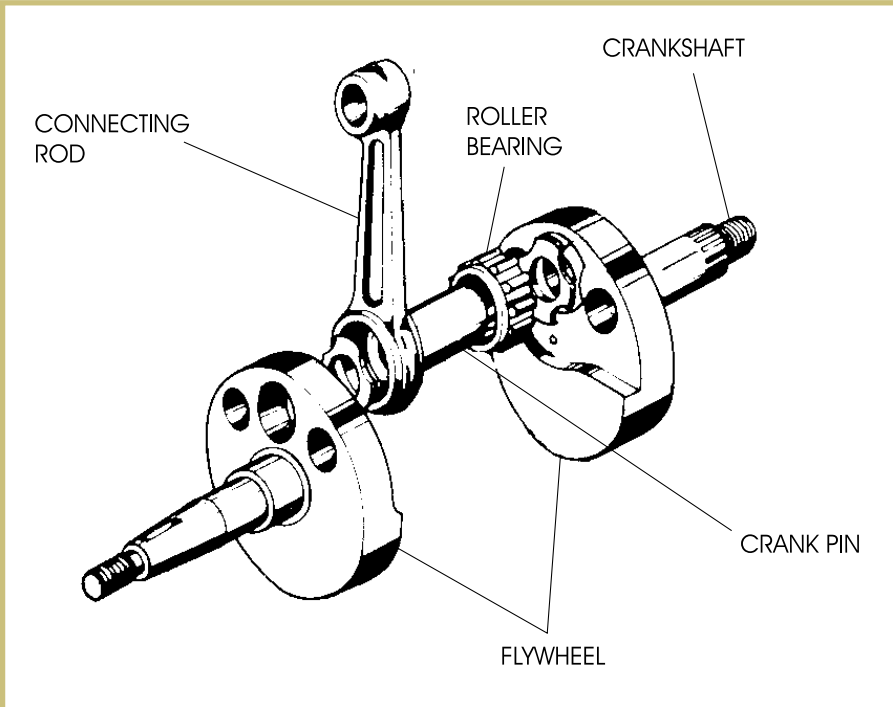
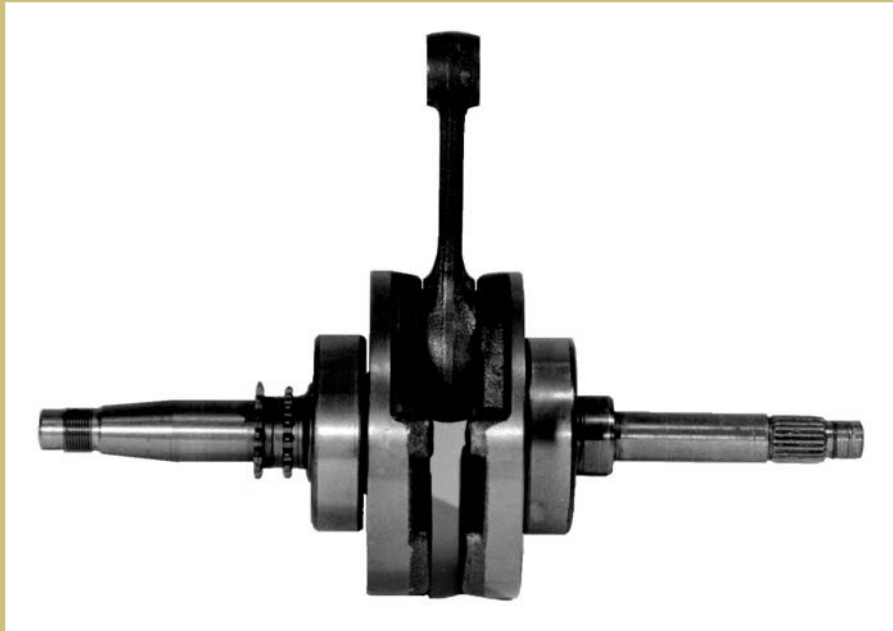

FIGURE 22—An Assembled Multipiece Four-Stroke Engine Crankshaft



Multicylinder Crankshafts

Multicylinder crankshafts use different offset positions for each cylinder, depending on the design (Figure 23).

- In the 360° design, both pistons move up and down together. This design requires more counterweight and tends to vibrate at higher engine speeds.
- In the 180° design, the pistons move in opposite directions. This design requires less counterweight and has less vibration at higher engine speeds. When this design is used on an in-line four-cylinder engine, a pair of 180° crankshafts are used.
- In the 120° design, the pistons move 120° apart from each other. This design is used on three- and six-cylinder engines. Six-cylinder engines use a pair of 120° crankshafts.

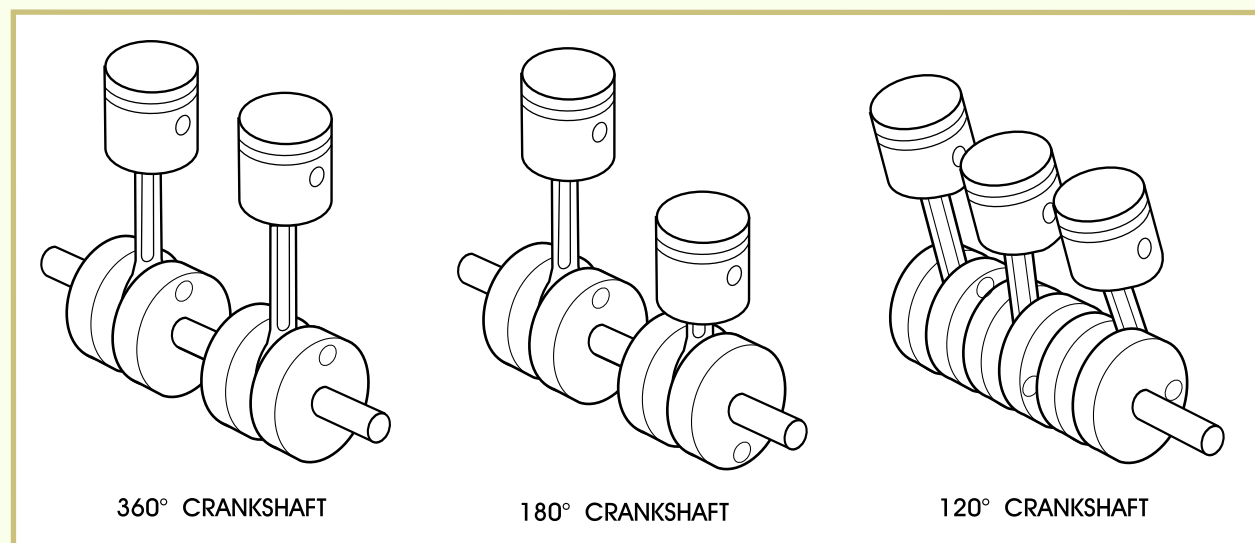

FIGURE 23—Multicylinder Crankshaft Designs (Courtesy of American Suzuki Motor Corporation)

Connecting Rods

The *connecting rod* is a lever that transfers power from the piston to the crankshaft. Connecting rods are usually made of forged steel, titanium, or aluminum and use an I-beam construction. There are two types of connecting rods used on four-stroke motorcycle and ATV engines.

- The *one-piece connecting rod* (Figure 24A) is the stronger in design. It uses a roller bearing at the larger end and must be used with a multipiece crankshaft. The one-piece connecting rod normally has holes or slots on both ends for added lubrication.
- The *multipiece connecting rod* (Figure 24B) is somewhat weaker in design when compared to the one-piece rod. The parts of the

multi-piece connecting rod consist of the connecting rod, connecting-rod end cap, and connecting-rod bolts and nuts. The multi-piece connecting rod uses a two-piece plain bearing at the larger end which normally requires high oil pressure for proper lubrication. The multi-piece connecting rod is normally used with a one-piece crankshaft.



FIGURE 24—This illustration shows the two types of connecting rods. Figure 24A shows a one-piece connecting rod with the piston attached. Figure 24B shows a multi-piece connecting rod with the piston detached.

Crankcases

The purpose of the *crankcase* is to contain and support the major engine components. These components can include the crankshaft, oil pump, cylinder, primary shaft, primary drive, transmission, and camshaft. The four-stroke crankcase must be vented to the atmosphere to prevent excessive pressure from building up inside the engine. Today, government regulations require that crankcase ventilation recirculate back through the combustion chamber.

There are three types of crankcases on four-stroke engines.

- *One-piece crankcases* consist of a case that's a single-piece construction with a separate access cover to remove parts.
- *Vertically split crankcases* consist of two case halves that separate vertically (Figure 25). This design requires the removal of the cylinders before the case halves can be split.
- *Horizontally split crankcases* consist of two case halves that separate horizontally. This design allows the bottom halves to be removed with the cylinder(s) still attached to the top half.

FIGURE 25—This engine has a vertically split crankcase design. The cylinder and cylinder head assemblies must be removed to split the crankcase halves.

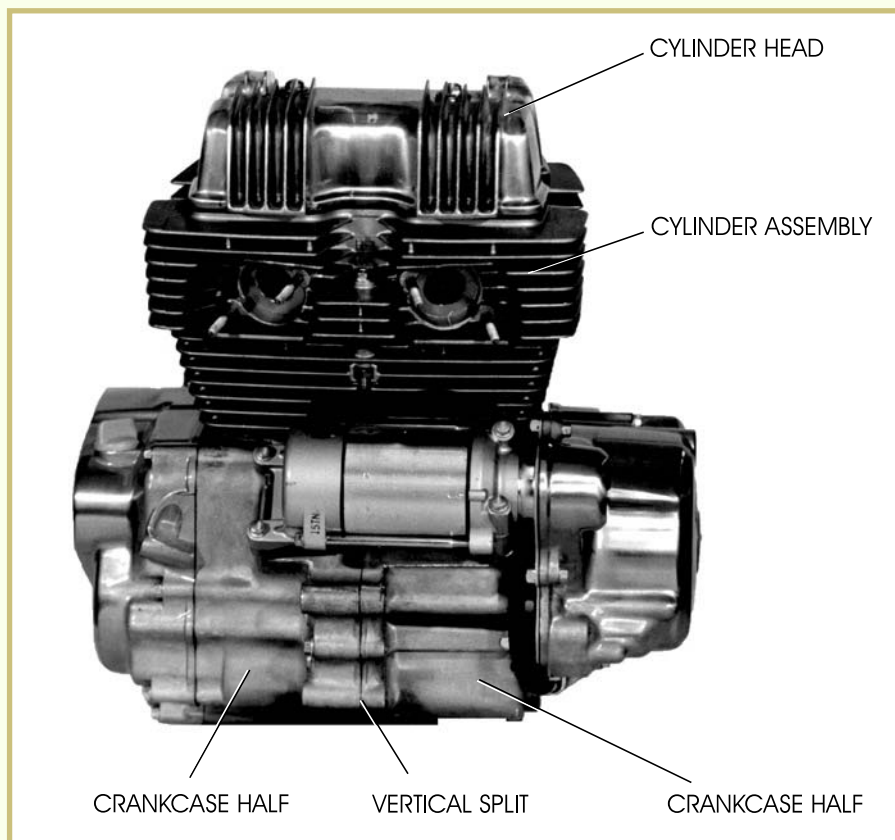

Road Test 3

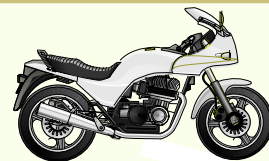

1. Piston ring end gap is measured using a _____.
2. The _____ attaches the piston to the connecting rod.
3. What type of valve lash adjuster automatically adjusts for proper clearances?

4. What are the three types of camshaft drives found on four-stroke motorcycle and ATV engines?

5. What's the purpose of honing a cylinder?

(Continued)

Road Test 3



6. The _____ ring is located closest to the piston crown.
7. What type of cylinder can't be bored to a larger diameter?

8. The camshaft in a four-stroke engine rotates at _____ the speed of the crankshaft.
9. What's valve overlap?

10. What crankcase design allows the bottom half to be removed and the cylinders to remain attached?

11. What part of the valve is considered a major wear area and if worn will allow excessive oil to pass into the combustion chamber?

12. *True or False?* The one-piece connecting rod is used with a multipiece crankshaft.

[Check your answers with those on page 37.](#)

FOUR-STROKE ENGINE THEORY OF OPERATION

Although the four-stroke engine is somewhat complex in design due to the parts necessary for it to function, it's relatively simple in terms of operation. The engine runs by repeatedly completing a cycle of operation. Each cycle of operation consists of two crankshaft revolutions in which four piston strokes occur. Each of the four piston strokes performs a distinct operation. The four operations (or stages) that are required for the engine to produce power are: intake, compression, power, and exhaust. These operations must occur in the proper order for the engine to run correctly.

Valve Operation

As we mentioned earlier, the four-stroke engine uses mechanical valves: the intake valve and the exhaust valve (Figure 26). These valves move up and down to open and close during engine operation. The *intake valve* opens to allow the air-and-fuel mixture to flow into the combustion chamber. The *exhaust valve* opens to allow exhaust

gases to flow out of the combustion chamber after the air-and-fuel mixture is burned.

The intake and exhaust valves are mechanically lifted to make them open and close. The valves are lifted by a valve-lifting device that rests on the lobes of the camshaft. As the camshaft turns, the lobes open the valves in a timed sequence to match up properly with the up-and-down motion of the piston. The valve springs hold the valves closed when they aren't being forced open by the camshaft and lifting device.

FIGURE 26—This illustration shows the intake and exhaust valves. These mechanical valves open and close to allow the air-and-fuel mixture into the engine, and the exhaust gases to leave the engine. The camshaft rotates with the crankshaft to push the valves open and allow them to close at the proper times. (Copyright by American Honda Motor Co., Inc. and reprinted with permission)

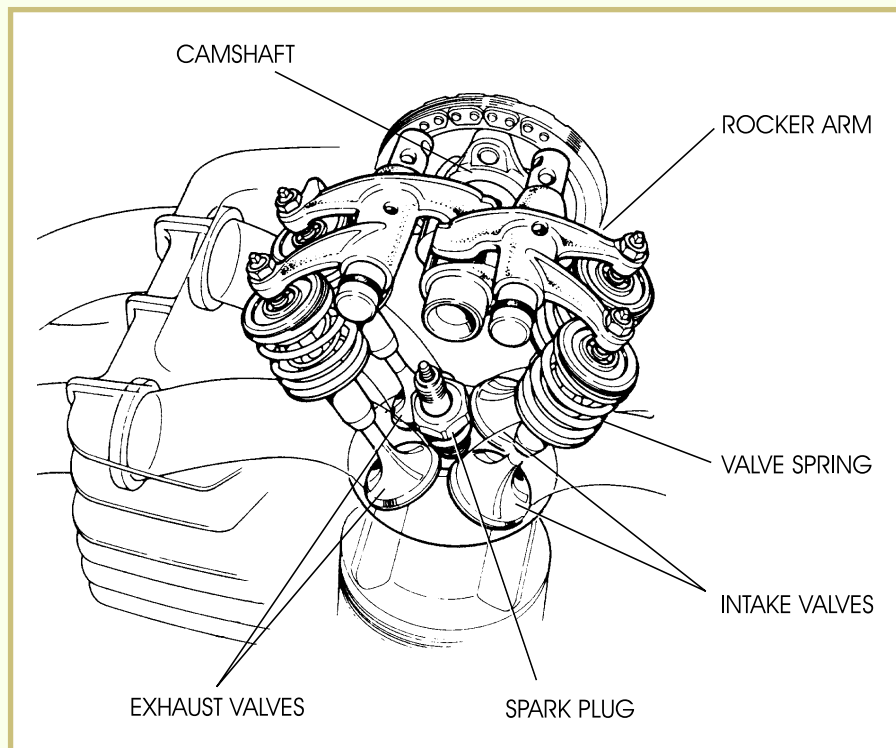

Carburetor

In order to burn properly in an engine, fuel must be mixed with air. The component that mixes the fuel and air is called a *carburetor*. Fuel moves from the fuel tank into the carburetor, where it's atomized and mixed with air. The air-and-fuel mixture is then transferred out of the carburetor and into the cylinder through the intake valve, where it's vaporized. We'll discuss the specific functions and details of the carburetor in a future study unit.

Now, let's take a closer look at the individual operations, known as strokes, that occur in the four-stroke engine (Figure 27).

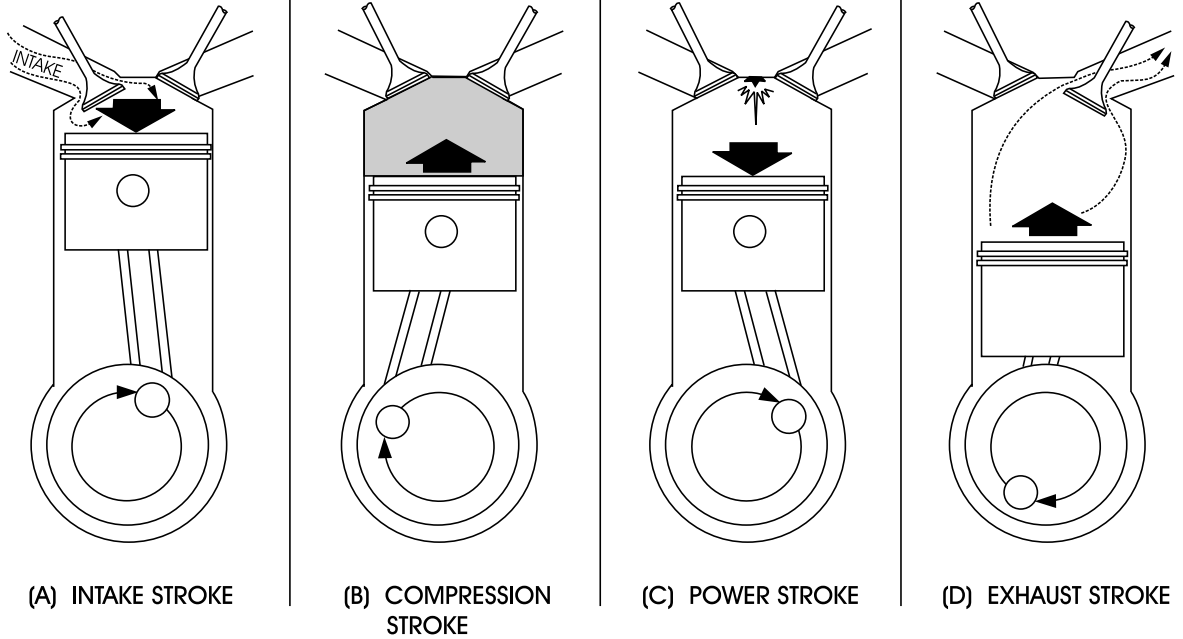

FIGURE 27—This illustration shows the four piston strokes in the sequence needed to complete one cycle of operation. An engine runs by repeatedly completing this cycle. (Courtesy Kawasaki Motor Corp., U.S.A.)

The Intake Stroke

On the *intake stroke*, the air-and-fuel mixture enters the cylinder. The intake sequence starts when the intake valve begins to open. As the piston moves downward in the cylinder away from the cylinder head, the volume of the cylinder above the piston expands. This increase in volume creates a low-pressure area which develops less-than-atmospheric pressure inside the cylinder. With the intake valve open, a path is completed through the intake manifold and carburetor. In an effort to balance the pressure difference between the atmospheric pressure of the outside air and the less-than-atmospheric pressure inside the cylinder, the outside air moves through the carburetor towards the cylinder. (Remember, a high-pressure area will always seek a low-pressure area.) The intake valve closes and seals the combustion chamber when the piston is near the bottom of its stroke near the crankshaft.

The Compression Stroke

When the piston approaches bottom dead center, both valves are closed. The air-and-fuel mixture is now trapped inside the sealed combustion chamber. At this point the piston begins to rise, which compresses the air-and-fuel mixture very tightly in the combustion chamber. This is known as the *compression stroke*.

The Power Stroke

Just before the piston reaches TDC during the compression stroke, the engine's ignition system fires the spark plug. That is, the ignition system produces an electric current that causes a spark to jump across the two electrodes of the spark plug. When the spark is applied to the compressed air-and-fuel mixture, a contained explosion occurs and the compressed air-and-fuel mixture is burned.

When gases explode, they expand rapidly. The force of this contained explosion pushes the piston down in the cylinder. The connecting rod, which is connected between the piston and crankshaft, causes the downward motion of the piston to force the crankshaft to rotate. This is known as the *power stroke*.

The Exhaust Stroke

As the piston moves downward during the power stroke, the exhaust valve opens. By the time the piston reaches bottom dead center, the exhaust valve is completely open. As the piston moves up again, it pushes the burned gases out the exhaust valve. This is known as the *exhaust stroke*.

Once the exhaust stage is completed, the four stages of operation begin again. The movement of the camshaft closes the exhaust valve and opens the intake valve, and the piston moves down to begin a new intake stage.

The four stages of operation continue as long as the engine is operating. Keep in mind that these cycles are repeated at a very high rate of speed. An average motorcycle engine crankshaft rotates anywhere from 1000 to 10,000 revolutions every minute. This means that these engine cycles are repeated thousands of times in a single minute.

Road Test 4

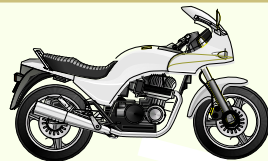

1. If the piston is rising towards TDC and both valves are closed, the engine is on the _____ stroke.
2. During the _____ stroke, the piston is moving down in the cylinder and the intake valve is open.
3. Hot gases are released from the engine during the _____ stroke.
4. During the _____ stroke, the air-and-fuel mixture is ignited and the explosion pushes the piston down in the cylinder.
5. The typical four-stroke engine contains mechanical valves called the _____ valve and the _____ valve.
6. In a four-stroke engine, the item that mixes the air and fuel together is called the _____.

Check your answers with those on page 37.

Road Test Answers

1

1. The air density will be reduced.
2. A liquid's resistance to flow
3. No
4. True
5. Anything at rest tends to remain at rest, and anything in motion tends to remain in motion, until acted upon by an outside force.
6. Active (or kinetic) energy and potential energy
7. The temperature increases.
8. Vaporized liquid

2

1.
 - a. Intake
 - b. Compression
 - c. Power
 - d. Exhaust
2. Air and fuel is drawn into the cylinder. The mixture is compressed. The mixture is ignited and burns. The gases are released.
3. Internal-combustion engines
4. cylinder
5. Piston rings
6. spark plug
7. Carbon monoxide (CO)
8. Top dead center (TDC)

3

1. feeler gauge
2. wrist pin
3. Hydraulic
4. Chain, belt, and gear
5. Honing helps to seat piston rings and retains oil on the cylinder wall for lubrication.
6. compression
7. Plated aluminum
8. one-half
9. The time that both the intake and exhaust valves are open simultaneously
10. Horizontally split
11. Valve stem
12. True

4

1. compression
2. intake
3. exhaust
4. power
5. intake, exhaust
6. carburetor



ONLINE EXAMINATION

For the online exam, you must use this

EXAMINATION NUMBER:

03300400

When you're confident that you've mastered the material in your studies, you can complete your examination online. Follow these instructions:

1. Write down the eight-digit examination number shown in the box above.
2. Click the **Back** button on your browser.
3. Click the **Take an Exam** button near the top of the screen.
4. Type in the eight-digit examination number.