

Study Unit

Introduction to Motorcycle and ATV Repair

By

Edward Abdo

Author Acknowledgment

Edward Abdo has been actively involved in the motorcycle and ATV industry for over 25 years. He received factory training from Honda, Kawasaki, Suzuki, and Yamaha training schools. He has worked as a motorcycle technician, service manager, and Service/Parts department director.

After being a chief instructor for several years, Ed is now the Curriculum Development Manager for the Motorcycle Mechanics Institute in Phoenix, Arizona. He is also a contract instructor and administrator for American Honda's Motorcycle Service Education Department.

Preview

Motorcycle and ATV (All-Terrain Vehicle) repair can provide an interesting career, a good income, and job security. To be successful at anything, you must set a goal and have the desire to achieve it. By enrolling in this program, you've already taken the first step on the path to success.

There are probably several reasons why you're interested in this program. You may be preparing to start a full-time career in the motorcycle repair field. Or, if you're already employed in another field, you may be interested in exploring new career opportunities. Perhaps you want to work only part-time, doing repair work occasionally to supplement your present income. Or maybe you're interested in saving money by repairing your own motorcycle or ATV. Whatever your goals and aspirations, welcome!

Whenever you start out to learn a new subject, it's very important to establish a solid base to build that learning on. This study unit will serve as an introductory base to the subject of motorcycle and ATV repair. This is your beginning step. Establish the solid base that will serve you throughout the program.

This study unit will introduce you to the expanding field of motorcycle repair and the increasing need for professionally trained motorcycle technicians. You'll learn about the many career opportunities available to trained technicians. You'll learn to identify the types of motorcycles and ATVs in operation today. You'll also learn about the different types of basic and specialized tools that motorcycle technicians use. Finally, you'll receive important instruction on safe work methods and the safe use of tools, equipment, and supplies related to motorcycle and ATV repair.

When you complete this study unit, you'll be able to

- List and describe the employment opportunities available in the motorcycle industry
- Identify the different types of motorcycles and ATVs
- Define the uses and advantages of each type of motorcycle and ATV
- Name the various hand, power, and specialized tools you'll use when working with motorcycles and ATVs
- State the safety concerns associated with hand and power tools
- Describe the safe work practices that you must observe when working on motorcycles and ATVs
- Explain how good housekeeping habits contribute to a safe workplace
- Identify the major classes of fires and describe how each should be extinguished

Contents

THE MOTORCYCLE AND ATV REPAIR FIELD	1
Introduction	
Dealership Opportunities	
Other Industry Opportunities	
TYPES OF MOTORCYCLES AND ATVs	8
Street Motorcycles	
Dual-Purpose Motorcycles	
Off-Road Motorcycles	
All-Terrain Vehicles (ATVs)	
TOOLS USED ON MOTORCYCLES AND ATVs	17
Basic Hand Tools	
Power Tools	
Special Tools	
Purchasing Tools	
Storing Tools	
Service Manuals	
KEY SAFETY ISSUES	56
The Safety Attitude	
Fire	
Hazardous Chemicals	
Electricity	
Exhaust Gases	
Safe Operation of Equipment	
Good Housekeeping Practices	
Handling Heavy Objects and Materials	
Using Personal Protective Equipment (PPE)	
Safe Riding Practices	
ROAD TEST ANSWERS	79
EXAMINATION	81

Introduction to Motorcycle and ATV Repair

THE MOTORCYCLE AND ATV REPAIR FIELD

Introduction

This section introduces you to the opportunities available in the motorcycle and ATV repair industry. Upon completing their training, many students obtain their first job as entry-level motorcycle and ATV repair technicians at motorcycle dealerships. There are several positions available at a motorcycle dealership for individuals with a motorcycle and ATV repair background. Even if you're not interested in a motorcycle repair industry career at this time, this section will give you an idea of what the industry is all about. To obtain a better understanding of the positions available at a motorcycle dealership, let's take a close look at the dealership.

Dealership Opportunities

A motorcycle and ATV dealership is an excellent place to begin a motorcycle and ATV repair career. Often, prospective employees must be willing to start at an entry-level position and work their way up the ladder. Most franchised and independent dealerships have three main departments:

- Sales department
- Parts department
- Service department

Before we discuss the service department, let's take a look at the other two departments first. It's possible that your entry job may be in the sales or parts departments. You can gain valuable experience in these departments until a position opens in the service department.

The ability to get along with people is a key requirement for working in any area of a motorcycle dealership. This is particularly true in the sales department. As a skilled salesperson, you must also be able to discuss the technical features of the different motorcycle and ATV models with customers. An education in motorcycle repair provides you with a definite advantage as a member of the sales staff. If you possess the ability to deal directly with customers, the sales department is an excellent place to learn how a motorcycle dealership operates. The sales area provides valuable exposure to business-related

activities. The experience can be very beneficial, especially if you plan to run your own business someday.

The parts department is also a great place to use your people skills. As a member of the parts department, you'll have constant contact with retail customers, the sales department, and the service department. You'll be dealing directly with customers, both in person and on the telephone.

The parts department is more closely related to the service department than to the sales department, especially if you work as a parts technician. A parts technician is responsible for supplying the service department technicians with the parts that they need to complete their service and repair work.

The third department within a motorcycle dealership is the service department. A small shop may have a service department that employs only one or two technicians. A medium-sized shop might employ three or four technicians plus a service manager. It's not unusual to find a significant number of employees in the service department of a large motorcycle dealership. A large motorcycle dealership typically employs the following personnel in the service department:

- Lot attendants
- Set-up technicians (motorcycle assemblers)
- Motorcycle technicians
- Service writers
- Service managers

If you're fortunate enough to get a job in the service department, but not as a technician, you may be employed as a lot attendant. A *lot attendant* is usually responsible for cleaning up the display lot and shop areas; rearranging, cleaning, and detailing motorcycles; picking up and delivering motorcycles and supplies; and performing other related tasks. If you start out as a lot attendant, the dealership management will have a chance to evaluate your job performance before assigning you additional responsibilities.

A *set-up technician* (also known as a *motorcycle assembler*) is a step closer to becoming a motorcycle technician. The set-up technician position requires certain mechanical skills. The set-up technician unpacks and assembles all of the new motorcycles received at a dealership. The set-up activity often includes the initial service of the motorcycle (oil, gas, adjustments, and power checks).

The *motorcycle technician* is frequently considered the backbone of the service department. It's not unusual to find motorcycle technicians who started in sales, in the parts department, as lot attendants, or as set-up technicians and worked their way up. As a motorcycle technician, you'll need a technical background, factory training (which the

dealership can arrange for you), tools, and usually some prior mechanical experience. Some of the job assignments and responsibilities of a motorcycle technician include

- Warranty service
- Preventive and scheduled maintenance
- General repair activities
- Staying current with new products, accessories, and service procedures
- Maintaining accurate repair records
- Alerting the service manager to actual or potential problems

In addition to the direct repair activity involvement of the motorcycle technician, there are other related positions available in most service departments for those who wish to try other assignments in the motorcycle service career field.

Another key employee in the service department is the service writer. The *service writer* is responsible for writing the repair orders for service work. He or she must be technically trained and must have a complete understanding of the service process. When writing a repair order, the service writer must obtain detailed failure information from the customer, verify the customer's input, and then provide the customer with an estimate of the services that might be required to correct the problem. In most dealerships, the service writer creates the repair orders, which are then distributed to the motorcycle repair technicians. The service writer also has a hand in job scheduling, ensuring that the repair process flows smoothly.

The *service manager* is the highest position in the service department. Most service managers are responsible for the following:

- Customer transactions
- Warranty claims
- Product update and information publications
- Technician training
- Employee hiring and dismissal
- Equipment needs
- Building maintenance
- Service policy changes
- Service files and records

Service managers usually have an extensive service background and prior management experience including

- Technical training
- Factory service school training
- Lot attendant experience
- Set-up/assembly experience
- Motorcycle repair experience
- Customer relations skills
- Management experience

The service manager has the overall responsibility for the service department. He or she must see that everything in the service department is well organized, that all necessary parts are in stock, and that the service work is performed correctly and completed on time. The service manager must handle all customer complaints and any technical questions from both customers and technicians. The service manager needs an extensive amount of motorcycle repair experience and excellent management skills.

Finally, the top position in a motorcycle dealership is the general manager. The *general manager* has the overall responsibility for the sales, parts, and service departments. He or she oversees the day-to-day operations of the entire business. A general manager is likely to have had experience in all of the other departments.

Other Industry Opportunities

Some individuals with motorcycle repair backgrounds (for example, motorcycle technicians and service managers) have found challenging career opportunities as motorcycle repair instructors. To be a *motorcycle repair instructor*, you must meet certain requirements. These requirements vary by locality. For example, in California a technical instructor must be certified. To be certified in California, a technician can apply for teaching credentials if he or she has qualified in one of the following ways:

- Seven years experience in the trade
- Five years experience in the trade plus two years of college (with a major in the specific trade)

Because of the growing popularity of motorcycles for sport and utility purposes, more motorcycle technical trade schools are opening every year. The demand for qualified motorcycle repair instructors is growing, especially at the post-high school, technical vocational level.

There are also teaching positions in most motorcycle manufacturing training schools.

Before seriously considering a career as a motorcycle repair instructor, be sure that you enjoy explaining the details of how something works, that you feel comfortable working directly with groups of people, and that you have an abundance of patience. The pay and benefits for the instructor position are usually good, but to some instructors the greatest single reward can be watching the students develop the ability to apply their newly acquired knowledge.

If you enjoy motorcycle repair theory more than you enjoy actually repairing motorcycles, it's quite possible that you would enjoy a career as a *technical writer*. Almost everything that you've read about motorcycle repair was written by one or more technical writers. Technical writers in the motorcycle industry are constantly in demand, especially if they're skilled at transforming technical ideas and concepts into everyday language.

Most technical writers have the following:

- Technical training
- Higher education (college)
- Writing experience

Most motorcycle photographs and illustrations contained in service manuals, sales brochures, and other printed matter are created by *technical illustrators*, who work closely with technical writers. Although most of the illustrations are created by the technical illustrators, in certain cases the illustrations are created by the technical writers themselves. At the very least, technical writers should be able to define the illustrations or photographs needed to support the text that they've developed, and to verify that the completed illustrations support the text. There's usually a close working relationship between technical writers and the technical illustrators to develop the finished printed material.

Most technical illustrators usually have the following:

- Technical training
- Some writing experience
- Photographic experience
- Technical illustration and layout experience

Another possibility worth exploring is in the area of motorcycle manufacturing. Companies in the manufacturing industry offer numerous career opportunities. Although the complete list is long and varied, these positions include

- Technical advisor
- District service manager
- District sales manager
- District parts manager
- Technical writer
- Technical illustrator
- Warranty coordinator
- Service training instructor
- Customer service coordinator
- Quality control specialist
- Research and development engineer
- Race team support technician
- Advertising and marketing specialist

Most motorcycle manufacturing company employees enjoy competitive salaries and generous company benefits. Before seriously considering a career with a motorcycle manufacturer, make sure that you've had most of the following:

- Related mechanical experience
- Employment at a dealership
- Technical training in a related field (small engines or electrical circuits)
- Factory service school training in motorcycle repair
- Higher education (college or vocational school)

We've explored several career opportunity options for someone who has the necessary skills and training in motorcycle repair. What about the person who wants to be self-employed? Are the days of the independent service technician over?

Not at all! With adequate financial backing, a person with the proper skills and background could start any type of related business, including a full motorcycle dealership, a parts and accessories store, or a major service and repair business.

It's possible for a trained motorcycle or ATV repair technician to start a small repair and service business with little available capital. Many of today's thriving repair and service businesses started out in the back of a garage. If self-employment is your goal, you might start out by using that spare space in your garage!

These are just some of the possibilities that await you in the exciting and challenging field of motorcycle and ATV repair. As you've discovered in this section, a wide range of career opportunities are available to qualified individuals.

Road Test 1

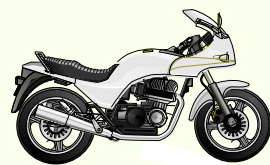

At the end of each section of *Introduction to Motorcycle and ATV Repair*, you'll be asked to pause and check your understanding of what you've just read by completing a "Road Test." Writing the answers will help you review what you've studied so far. Please take time to complete *Road Test 1* now.

1. Name some of the positions available in a motorcycle and ATV service department.

_____.

2. Name the three main areas/ departments in a motorcycle dealership.

_____.

3. Identify four of the areas that a service manager has probably had experience in.

_____.

4. The three things that service writers must do with a customer when they write repair orders are _____, _____, and _____.

5. A _____ is also known as a motorcycle assembler.

6. Name some of the service manager's responsibilities.

_____.

7. What types of experience is a motorcycle technical writer likely to have?

_____.

8. List five of the positions available in the motorcycle manufacturing field.

_____.

Check your answers with those on page 79.

TYPES OF MOTORCYCLES AND ATVs

Note: In our discussion of motorcycles and ATVs, when we use the generic term *motorcycles*, it's meant to include ATVs. The only exceptions will be when we're discussing ATVs exclusively. At those times, we'll specify *ATVs* in the discussion.

Motorcycles are available in a variety of models and sizes. The model that a customer purchases depends primarily on the intended use and personal choice. However, all motorcycles have basic similarities. They all contain common components such as

- Engines
- Electrical systems
- Tires and wheels
- Handlebars with controls
- Fuel tanks
- Brakes
- Seats
- Frames
- Suspension systems

These components form systems that must work together to provide a dependable and safe means of transportation. Each system performs a specific function. For example, the fuel system supplies the correct ratio of air-to-fuel mixture for proper engine operation. The ignition system provides timed electrical sparks to ignite the air-and-fuel mixture in the engine's internal combustion chamber(s). The drive train mechanism transfers the energy from the engine to the drive wheel(s). The brake system stops the motorcycle quickly and safely. Finally, the frame and suspension system absorb vibration and shock, to give the rider a smoother, more comfortable ride over varying road surfaces.

Because of the numerous applications and uses, motorcycles are divided into categories by use. Each category is then subdivided by engine displacement.

Engine displacement is a size measurement given in *cubic centimeters (cc)*. For example, a 1000 cc engine has 1000 cubic centimeters of volume. If it's a four-cylinder engine, then each cylinder has 250 cc of volume. If it's a two-cylinder engine, then each cylinder has 500 cc of volume. We'll cover exactly how this measurement is calculated in another study unit.

Motorcycles are classified as

- Street
- Dual-purpose
- Off-road

ATVs are classified as

- Three-wheelers
- Four-wheelers

Now, let's look at the different classifications of motorcycles and ATVs.

Street Motorcycles

Street motorcycles are available in a wide variety of designs and sizes. As the name implies, *street motorcycles* are designed for use on paved roadways. The standard street motorcycle has an upright riding position, has easy-to-reach controls, and has no wind fairing (Figure 1). The *wind fairing* is a molded shield designed to reduce wind drag and provide wind shielding for the rider.

FIGURE 1—This is an example of 750 cc standard street motorcycle. (Courtesy of Kawasaki Motor Corp., U.S.A.)



Today's standard street motorcycles were initially designed by Japanese manufacturers in the late 1960s and early 1970s. They picked up the designation of *UJM* (*Universal Japanese Motorcycle*) after millions were built and sold. Although the current crop of standard street motorcycles is derived from the UJM version, early models of a very similar style were available from American manufacturers long before the UJM models were first imported here. These early American versions of the street motorcycles were customized by their owners into a unique class of vehicles known as custom cruisers.

The standard street motorcycle is still very popular. It's available in a variety of different engine and chassis sizes, to fit almost anyone's needs. The standard street motorcycle is often thought of as entry-level in motorcycling circles, although many experienced riders purchase them for their daily use.

A variation of the standard street motorcycle is the *custom cruiser* (Figure 2). The custom cruiser design began as a set of modifications to production models of the standard street motorcycle. Custom cruisers started to evolve when riders began to customize their standard street motorcycles. This customizing, which began in the United States, focused on modifying handlebar and seat design.

FIGURE 2—A medium (500 cc) custom cruiser. Note the laid-back riding position.
(Courtesy of Kawasaki Motor Corp., U.S.A.)



The motorcycle manufacturers recognized the growing popularity of the customized models, and started building factory versions. These manufactured custom cruisers have grown into one of the largest and most popular sales offerings of the motorcycle industry. A major difference between standard street models and custom cruisers is the riding position. Standard street models are ridden in the upright position, and custom cruisers have a laid-back riding position. Custom cruisers come in a variety of sizes and feature many different looks.

Hot-rod cruisers (Figure 3) are another spin-off of the standard street motorcycle, and are similar to custom cruisers. The riding position of hot-rod cruisers is slightly forward-leaning. Hot-rod cruisers are equipped with large, powerful engines. Although hot-rod cruisers aren't new to the industry, they're regaining popularity. Manufacturers have redesigned the chassis and suspension systems on the hot-rod cruisers to accommodate the larger engines and the increased power common with this class of motorcycles.

FIGURE 3—Shown is an example of a hot-rod cruiser.
(Courtesy of Kawasaki Motor Corp., U.S.A.)



From a performance standpoint, *sport motorcycles* (Figure 4) are the fastest, best-stopping, and best-handling members of the street-type motorcycles available to the public. They're available in a wide variety of sizes and power options. Many sport motorcycles are used in road racing.

FIGURE 4—A Kawasaki 250 Ninja is an example of a small sport motorcycle.
(Courtesy of Kawasaki Motor Corp., U.S.A.)

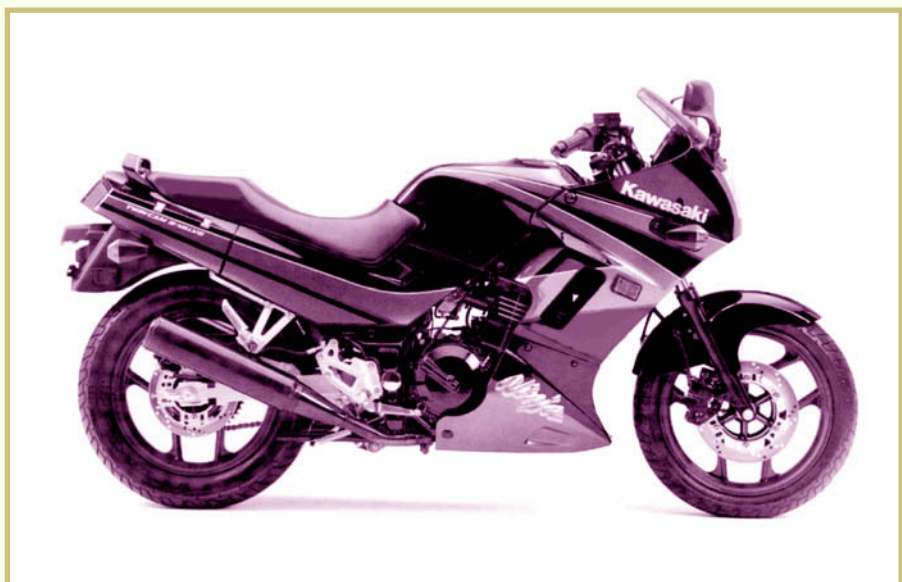

As the name suggests, *touring motorcycles* are large, well-equipped units designed for long-distance touring travel (Figure 5). Many are equipped with standard and optional features such as AM/FM and CB radios, tape players, and even cruise control. Most touring motorcycles come equipped with large *fairing units* (windshields and wrap-around side panels) to protect riders from the elements. They're also equipped with large, weatherproof saddlebags to carry and protect luggage.

FIGURE 5—The touring motorcycle comes equipped with everything needed for long, cross-country trips. (Courtesy of Kawasaki Motor Corp., U.S.A.)



Sport-touring motorcycles are designed for touring without some of the frills of the pure touring version (Figure 6). Options such as radios and cruise control aren't part of the sport-touring motorcycle design. Sport-touring motorcycles have high-performance engines, they handle very well at high speeds, and they provide a comfortable riding position (which is a must for long trips).

FIGURE 6—The sport-touring motorcycle is designed for a comfortable no-frills, long-distance ride. (Courtesy of Kawasaki Motor Corp., U.S.A.)



Motor scooters are the smallest members of the street category of motorcycles (Figure 7). They're offered with engine displacements from 50 cc to 250 cc. Because of their small design, they're very economical to operate and easy to park or store. The characteristics of the typical motor scooter make them excellent for daily, short-distance urban or suburban commuting. They can be equipped with saddlebags to provide limited space for carrying small parcels, books, and briefcases.

FIGURE 7—The motor scooter is available with various engine size options. (Copyright by American Honda Motor Co., Inc. and reprinted with permission)



Dual-Purpose Motorcycles

Dual-purpose motorcycles are exactly what the name suggests (Figure 8). They've been designed and manufactured to perform well both on and off paved highways. Dual-purpose motorcycles share mechanical characteristics with both street motorcycles and off-road motorcycles. These motorcycles are great for riders who might desire to take the conventional route to work or school and then choose to take the road less traveled on the return trip, using trails or fire roads instead of paved highways.

FIGURE 8—A Typical Dual-Purpose Motorcycle
(Courtesy of Kawasaki Motor Corp., U.S.A.)



Dual-purpose motorcycles are equipped with more shock-absorbing suspension systems than standard street motorcycles, to handle off-road conditions. They also have special tires for improved traction on all road (and non-road) surfaces. Dual-purpose motorcycles are becoming more popular with individuals who appreciate their versatility. Because of this growing popularity, an increasing number of specialized dual-purpose riding events, meets, and contests are being held each year. These events are designed to test the versatility of the dual-purpose motorcycles and the skills and handling techniques of the riders.

Off-Road Motorcycles

As the name implies, this category of motorcycles is specifically designed for off-road use. *Off-road motorcycles* are built to handle rough terrain. The frames, suspension systems, and wheels are considerably stronger than those found on standard street motorcycles. Off-road motorcycles are often used in extreme terrains such as deserts and mountain trails. Another use for off-road motorcycles that you may be familiar with is motocross. *Motocross* is defined as a motorcycle race on a tight, closed course over natural terrain that usually includes sharp turns, steep hills, and mud or water.

Because of their special use, off-road motorcycles have little need for lights, so most models aren't equipped with headlights and taillights. Certain special events such as 24-hour scrambles require lights, but this is the exception rather than the rule. Off-road motorcycles are available in a wide variety of sizes from small to large and powerful (Figure 9). They're offered with both two-stroke engines and four-stroke engines. The engine sizes vary from 50 cc to over 600 cc.

FIGURE 9—Off-road motorcycles come in various shapes and sizes. This is a small 50 cc off-road motorcycle. (Courtesy of Kawasaki Motor Corp., U.S.A.)



All-Terrain Vehicles (ATVs)

All-terrain vehicles (better known as *ATVs*), are a separate branch of the motorcycle family tree. ATVs are available in a variety of sizes and styles. They can be equipped with either two-stroke or four-stroke engines ranging from 50 cc to over 500 cc.

There are two subclasses of ATVs:

- Three-wheel, tricycle-style models, commonly referred to as *three-wheelers*
- Four-wheel models, commonly referred to as *four-wheelers*. Four-wheelers are further divided into two-wheel drive and four-wheel drive models.

ATVs are versatile. They can be used for pleasure, such as off-road and back-country touring/camping (Figure 10), for racing in both closed-course and straight-line sprints (Figure 11), or for work and utility purposes (Figure 12). There are design differences to support the different uses. An ATV model designed for pleasure isn't well suited for either racing or work. Likewise, a racing model isn't designed for work.

As mentioned earlier, ATVs have been produced as both three-wheelers and four-wheelers. Although thousands are still in use, three-wheelers are no longer in production. They have a tendency to be unstable, especially on rough and uneven terrain. For safety reasons, they've been discontinued. Owners of three-wheelers have been alerted to use caution when operating this type of ATV.

FIGURE 10—An ATV Built for Pleasure Riding (Image courtesy of Yamaha Motor Corporation, U.S.A.)



FIGURE 11—An ATV Built for Racing (Courtesy of American Suzuki Motor Corporation)



FIGURE 12—An ATV Built for Work (Courtesy of Kawasaki Motor Corp., U.S.A.)



Road Test 2

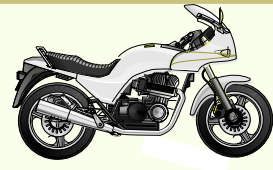

1. Name six similarities that all motorcycles and ATVs share.

2. The _____, _____, and the _____ are the three main classifications of motorcycles.
3. Although thousands are still in use today, the _____ ATV is no longer in production.
4. What size engines do ATVs usually have?

5. The _____ motorcycle is often used for road racing.
6. "UJM" stands for _____.
7. The _____ motorcycle is often factory equipped with radios, tape players, and even cruise control.
8. The _____ motorcycle usually has no lighting equipment.
9. What size engines do motor scooters usually have?

Check your answers with those on page 79.

TOOLS USED ON MOTORCYCLES AND ATVs

Motorcycle and ATV technicians use virtually hundreds of different tools to perform a wide variety of repair activities. In addition to the standard hand and power tools that you're already familiar with, there are specialized and precision repair tools that will probably be new to you. The assortment of tools that you'll use depends primarily on the types of vehicles you'll encounter, and the specific systems that you'll be responsible for. As an example, if you specialize in electrical systems, you'll need different tools than someone who specializes in internal engine repairs.

Skilled professionals, no matter what their trade or field, know how to use tools correctly and safely. Knowing exactly which tools to use for each task is essential for completing quality repair jobs quickly, safely, and most efficiently.

When you gain experience in the motorcycle and ATV repair field, you'll acquire the skills to do jobs faster and more efficiently. A large part of this skills development will focus on your ability to use the tools of the trade correctly.

Motorcycle and ATV repair tools can be divided into the following:

- Basic hand tools
- Power tools
- Special tools

It would be virtually impossible for us to discuss every type of motorcycle and ATV repair tool in this study unit. For this reason, we've limited our discussion to the tools that you'll use most often.

You've probably used many of the standard hand tools that we'll cover. But you may be totally unfamiliar with some of the specialized tools and measuring/testing instruments that we're going to introduce you to. We suggest that you take your time as you read about the various tools and instruments, and familiarize yourself with their use.

Basic Hand Tools

Basic hand tools are the common tools that are found in just about every workshop toolbox. Some of these basic hand tools include screwdrivers, hammers, pliers, wrenches, and socket sets. Because these tools are used so frequently, most motorcycle repair technicians own a complete set of hand tools similar to the example (Figure 13).

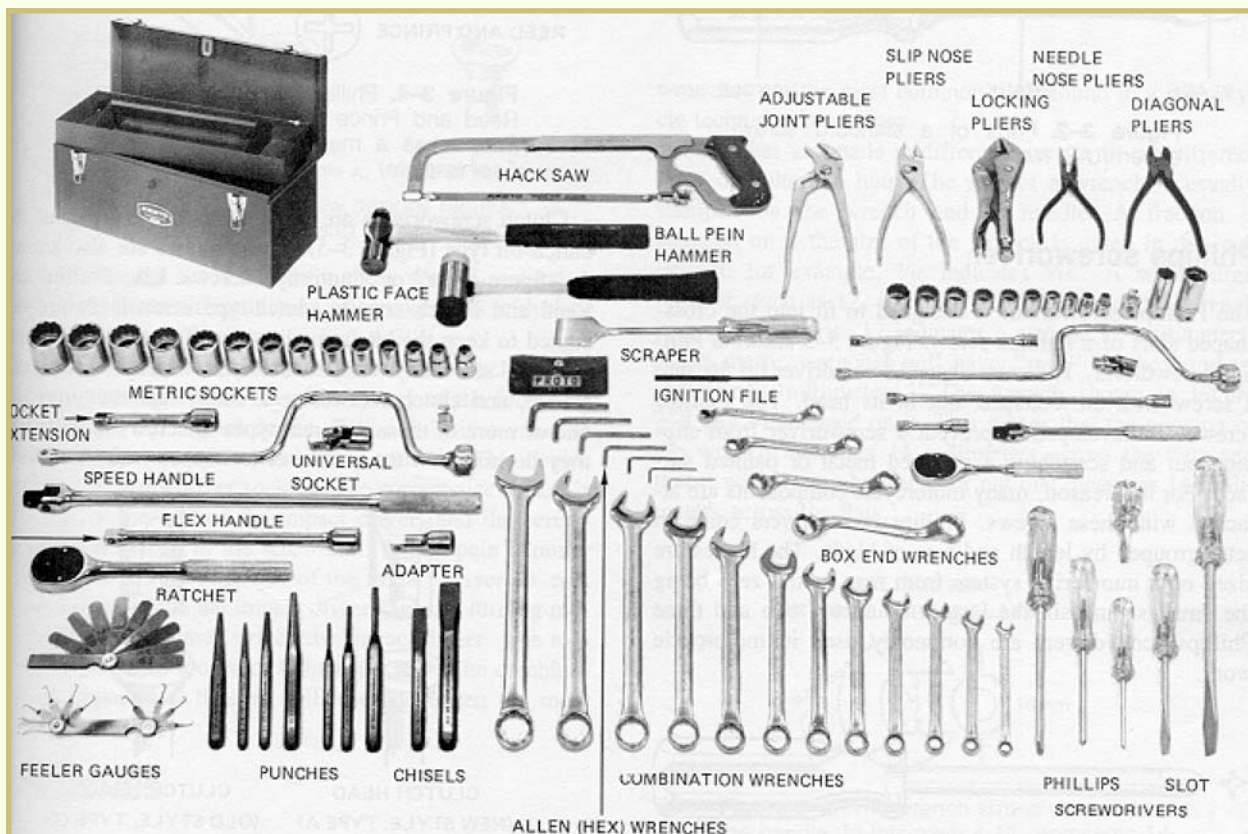

FIGURE 13—This illustration shows a typical set of hand tools that a motorcycle repair technician would probably own. This assortment of tools can be used for many purposes, and isn't limited to motorcycle repair.

Most of the basic hand tools are undoubtedly familiar to you. You've probably used them, and may even own most of them. To be sure that you understand the proper use of these tools, we'll take a brief look at each of them. Let's begin with the most commonly used of all hand tools, the wrench. The largest portion of your current tool collection probably consists of different types of wrenches.

Wrenches

Wrenches are used to tighten or loosen nut-and-bolt-type fasteners. As you probably know, wrenches come in a variety of sizes from very small to very large. The size of a wrench is determined by the width of the opening at the end of the wrench (Figure 14). Metric and SAE (Society of Automotive Engineers) are the general classifications of the wrenches found in a motorcycle technician's toolbox. *Metric wrenches* are measured in millimeters, such as 10 mm, 11 mm, and 12 mm. *SAE wrenches* are measured in fractions of an inch, such as $\frac{1}{2}$ inch, $\frac{1}{16}$ inch, and $\frac{5}{8}$ inch. As a rule of thumb, American-made motorcycles require SAE tools, and foreign-made (primarily Japanese) motorcycles require metric tools.

FIGURE 14—The width of the end opening is the wrench's size designation.

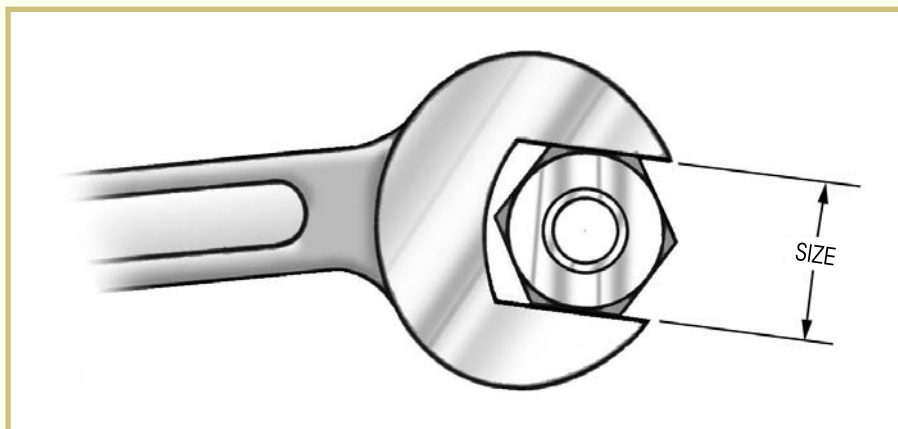

Wrenches are forged from strong, tempered steel. Each wrench size is designed to fit one particular-sized fastener. A common mistake when using wrenches is to use the wrong size (where the wrench *almost* fits). Using the wrong size wrench not only damages the fastener, it can also damage the wrench.

In addition to varying sizes, wrenches are also available in different styles (Figure 15). The five most common styles are the

- Open-end wrench
- Box-end wrench
- Combination wrench
- Adjustable wrench
- Socket wrench

FIGURE 15—This illustration shows four styles of wrenches.

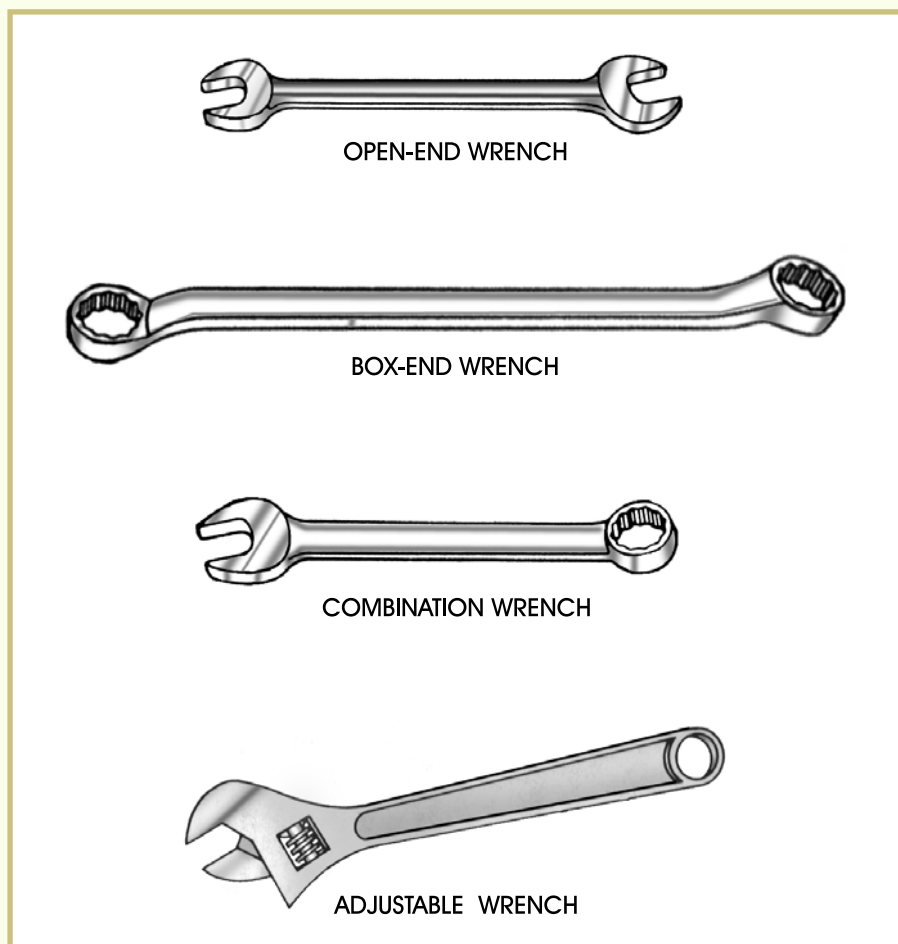

Open-end wrenches have U-shaped openings at the ends, and are designed so the length of each wrench is proportional to the size of its opening. The larger the opening, the longer the wrench handle, and the more rotational force that can be applied. *Rotational force* is referred to as *torque*. Because of the open-end wrench's design, you should never use an extension on a wrench handle to increase the torque. Using any type of handle extension could break the wrench and possibly cause an injury.

There are a number of different types of open-end wrenches. Some examples include:

- The *standard wrench* has a 15° head angle with a different size opening on each end.
- The *flare-nut* or *line wrench* is used for fuel/oil line fittings or brake lines. The head contacts 270° of the nut for a secure grip while allowing for access around fuel and oil lines.
- The *dual-angle wrench* usually has a 30° head angle on one end and a 60° angle on the other. The opening size is usually the same on both ends.

When using an open-end wrench, always place the wrench squarely on the nut or bolt and pull towards you. Using this position reduces the chance of injury. Open-end wrenches have a tendency to slip when high torque is applied. If you must use a pushing motion, push with the palm of your hand. Don't grip the wrench with your fingers. You've probably heard the term "knuckle buster." Guess where it came from! And always keep your wrenches clean to help prevent slipping.

Box-end wrenches should be used to loosen very tight bolts or nuts. The end of a box-end wrench encircles a nut or bolt head, providing more contact surface than an open-end wrench. Box-end wrenches have thin heads. This makes box-end wrenches useful in tight places where there's limited access space around the nut or bolt head. Box-end wrenches are available with 6-point and 12-point openings. The number of points refers to the inside shape of the box end (Figure 16).

FIGURE 16—This illustration shows 6-point and 12-point box-end wrenches.

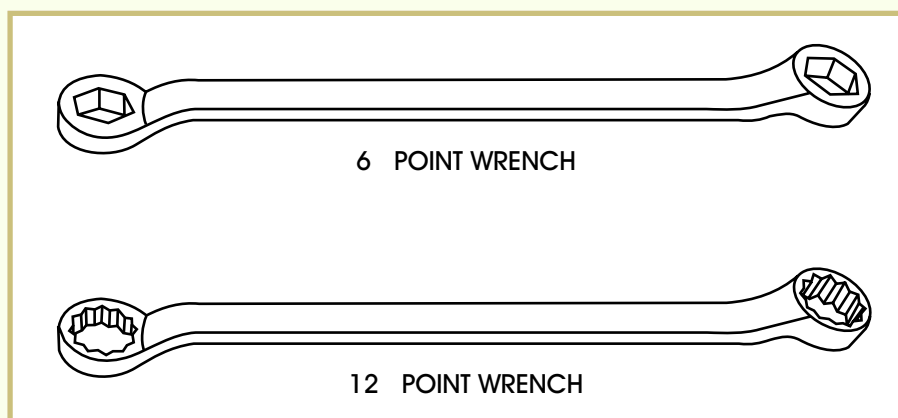

A 6-point box-end wrench provides more support to the head of a bolt than the 12-point box-end wrench. You should use a 6-point wrench on bolts and nuts that are very tight. The 6-point wrench is less likely to slip than a 12-point wrench. The main disadvantage of the 6-point wrench is that its head is thicker than that of a 12-point wrench. Also, a 6-point wrench can be placed on a bolt or nut in only six different positions.

Because its head is thinner and can be placed on the bolt or nut in 12 different positions, the 12-point style wrench is the better choice to use in tight places. You frequently can't get enough wrench *travel* in tight places to advance a 6-point wrench to the next turning position. With a 12-point wrench, the travel required to turn to the wrench to the next position is only half that required for the 6-point wrench. Remember, a 6-point box-end wrench is stronger and grips the fastener more securely, and a 12-point usually works better in tight spaces.

Combination wrenches combine the open-end wrench and the box-end wrench into one tool. In most cases, both ends of the combination wrench are the same size. This allows you to use the box-end to

loosen bolts or nuts that are tight, and the open-end to quickly remove them when they're loose.

Adjustable wrenches have movable jaws that allow you to adjust the opening to fit almost any size nut or bolt. But adjustable wrenches don't grip the fastener as tightly as other types of wrenches. Adjustable wrenches have a tendency to slip and round off the corners of nuts and bolt heads. Because of this limitation, adjustable wrenches should only be used to remove bolts or nuts that are already loosened. Adjustable wrenches can be used in a pinch, when the correct size of wrench isn't available. Remember that adjustable wrenches can slip! When using them, always pull towards you to save your knuckles!

Socket wrenches are among the more frequently used tools. Socket wrenches are usually purchased in sets (Figure 17). The individual sockets contained in a set are in graduated sizes. The size of the socket refers to the size of the bolt head or nut that the socket fits. Socket sizes range from small ($\frac{1}{8}$ inch or 3 mm), to very large (to match the largest available bolt and nut sizes).

FIGURE 17—This is a typical set of socket wrenches.
(Courtesy of Sears Craftsman)



There are two basic depths of sockets, standard and deep (Figure 18). *Deep sockets* allow access to recessed fasteners or nuts that are threaded onto studs. Sockets are available in 6- and 12-point configurations similar to box-end wrenches. The 6-point is the stronger. The 12-point is good for tight areas but is more likely to round off the nut

or bolt. Some sockets have fluted corners designed to place stress on the sides of the fastener. This design tolerates higher torque with less chance of rounding off the nuts or bolt heads.

FIGURE 18—Examples of Standard and Deep Socket Wrenches

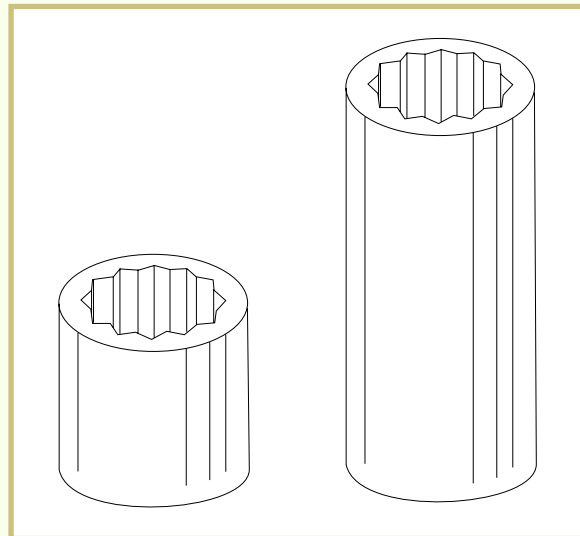

Sockets come in various degrees of hardness. The strongest are made for use with impact drivers and are usually black in color. Hand-type sockets are usually chrome-plated and aren't meant to be used with air or electric impact drivers.

Sockets can be installed onto different types of handles. The drive lug on the socket handle fits into the drive hole in the socket. Sockets come with different drive hole sizes: typically $\frac{1}{4}$ inch, $\frac{3}{8}$ inch, and $\frac{1}{2}$ inch.

The most common handle is the reversible ratchet handle (Figure 19). A lever on the handle allows you to change direction to either tighten or loosen fasteners (Figure 20). Reversible ratchet handles are great for removing and installing fasteners quickly. But they can be damaged if too much torque is placed on them. If you're using a socket to loosen an exceptionally tight fastener, use a breaker bar, not a ratchet handle, to turn the socket. A *breaker bar* is a non-ratchet solid handle with a socket drive fixed on its end. Because a breaker bar has no ratchet mechanism, it can withstand much more torque than a ratchet handle.

FIGURE 19—Different styles and sizes of reversible ratchet handles are shown here.

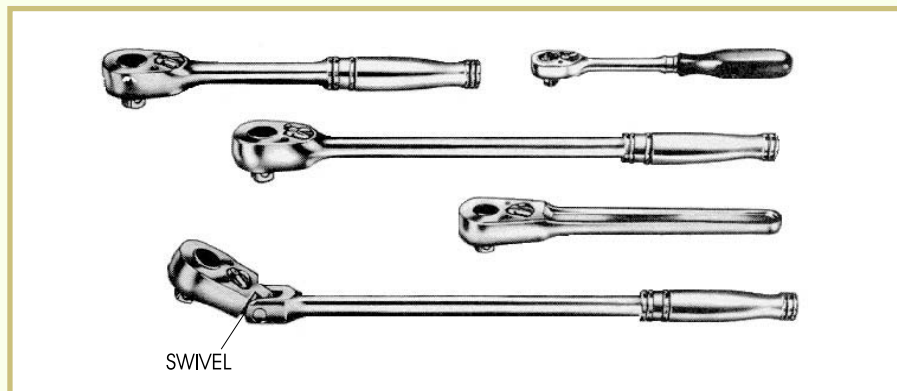
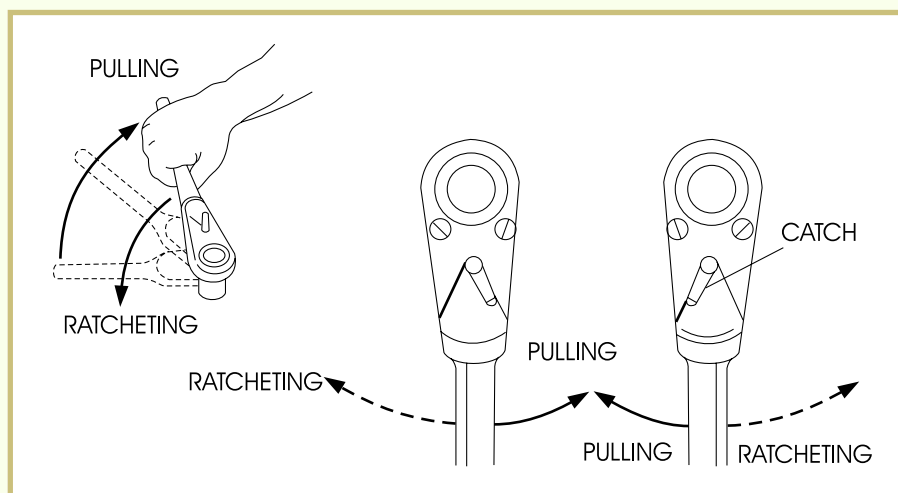
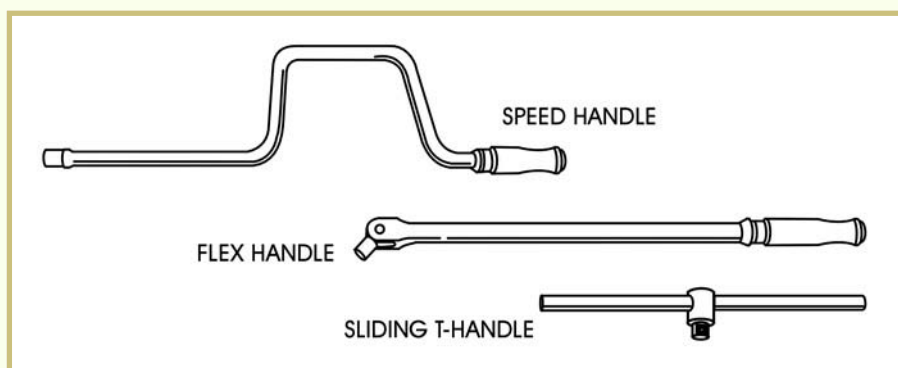

FIGURE 20—This illustration shows a reversible ratchet handle. Note the shift lever that's used to change the direction of the ratchet action.



Other popular handles include *speed handles*, *sliding T-handles* and *flex handles* (Figure 21). These handles are often used to turn sockets in tight spaces. Most socket sets also contain a variety of extension bars and adapters. These accessories allow the sockets to be used in many different situations.

FIGURE 21—Different types of socket drivers are shown here.



The *Allen wrench* or *hex wrench* is a short, six-sided rod that's used to tighten screws and bolts that contain similar six-sided (hex) indentations (Figure 22). A typical Allen wrench has a right-angle bend near one end. The bend forms a convenient handle. Certain special Allen wrenches are equipped with T-handles or screwdriver-style handles, and others are made to be used with a socket wrench drive handle. Allen wrenches can be purchased individually, but they're normally sold in sets that contain all of the commonly used sizes.

The *Torx wrench* is similar to the Allen wrench, except the end of the Torx wrench is star-shaped (Figure 22). Because they can handle more torque without slipping or stripping, Torx wrenches and bolts are used where higher fastening strengths are required. Torx bolts are ideally suited for use with impact tools. Torx wrenches are also available with T- or screwdriver-type handles, or attachable to socket wrench drive handles.

FIGURE 22—This illustration shows an Allen wrench and a Torx wrench. (Courtesy of Eklind Tool Co.)

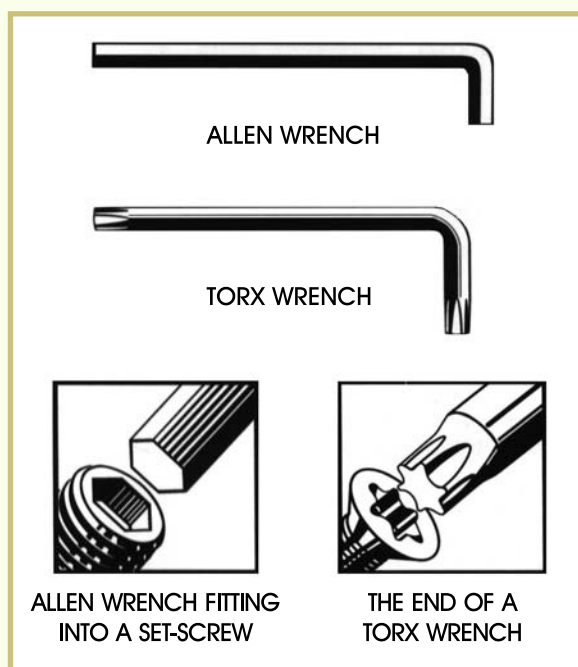

Screwdrivers

Even though just about everyone is familiar with the standard screwdriver (Figure 23), let's do a quick review. A standard screwdriver has the following:

- A handle which is usually made from plastic or wood
- A shaft which can be round, square, or hex. If it's square or hex, you can use a wrench on the shaft to increase torque.
- A tip or blade which you insert into the screw head slot

FIGURE 23—The basic parts of the standard screwdriver are shown here.

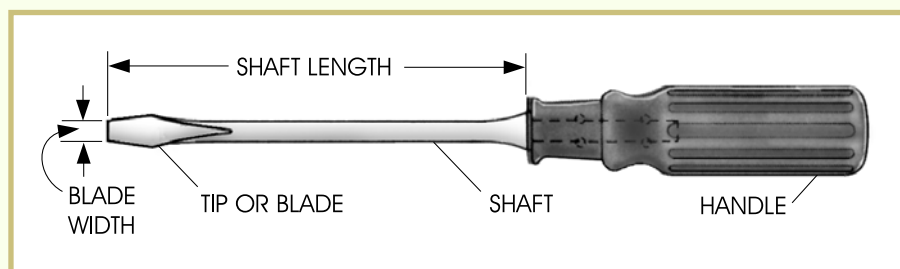

The screwdriver is one of the most abused hand tools. Have you ever

- Used a screwdriver as a pry bar or chisel?
- Used a screwdriver handle as a hammer?
- Hammered directly on a screwdriver handle?
- Used the wrong size screwdriver?
- Used the wrong type of screwdriver?

See what we mean? There are so many opportunities to misuse screwdrivers. Almost every one of us has done one or more of these things at one time or another! If used improperly, the screwdriver can cause damage. It can even injure you!

Screwdrivers are available in a variety of shaft lengths and tips (Figure 24). Here are the most common:

FIGURE 24—These screw head shapes are used in many different applications.

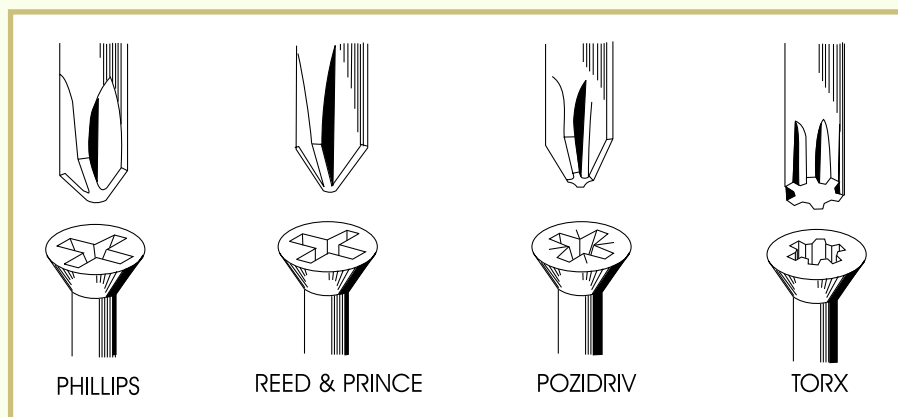

- *Flat or slot tips* range in size from very small ($\frac{1}{16}$ inch wide) to large ($\frac{3}{4}$ inch or wider). Choose the correct size for the fastener (Figure 25).
- *Phillips screwdriver tips* have a crossed point but a somewhat blunt end. These tips have good holding power and are less likely to slip than slotted tips. The common sizes of Phillips screw head slots used in motorcycle work are #1, #2, and #3.
- *Reed and Prince tips* are similar to Phillips but have a sharper tip. Reed and Prince tips aren't interchangeable with Phillips tipped screwdrivers.
- *Pozidrive tips* are similar to the Phillips and Reed and Prince tips.
- *Torx tips* are used when higher fastening strengths are required, because they can handle more turning force without slipping.

Screwdrivers are also available in special shapes to provide access in restricted areas. Several of the special-shaped screwdrivers are described here.

Offset screwdrivers are a special-purpose tool with an angled tip to allow access where space is limited. The offset screwdriver comes with either slotted or Phillips tips and is available in different sizes.

Stubby screwdrivers have a short shaft and a short, fat handle. Like the offset style, the “stubby” is used in cases where there's limited access space. The stubby screwdriver is available with either slotted or Phillips tips.

FIGURE 25—The blade of a screwdriver should fit the screw slot snugly to prevent slipping and slot damage.

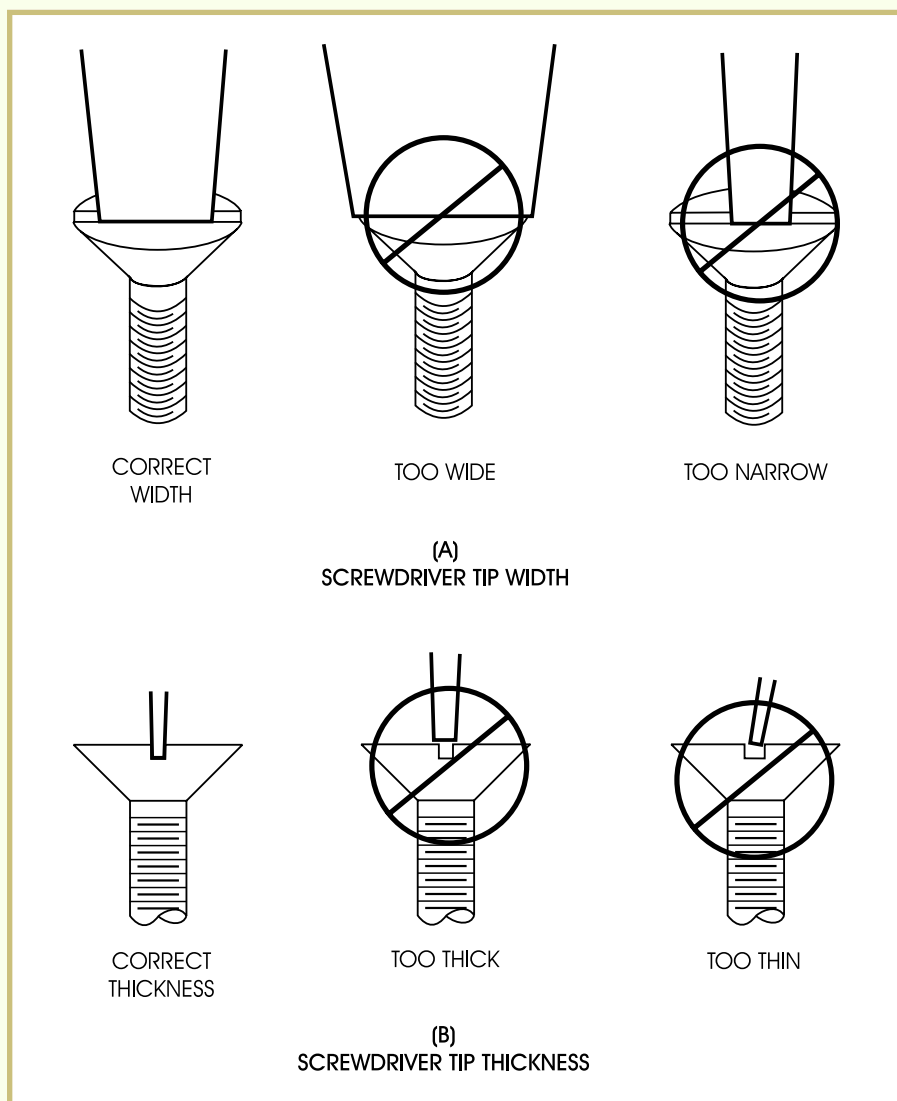

Angled or remote screwdrivers have a hollow tube with a handle on one end and a bit on the other end. They're used for jobs where you can't get hand access. Some are curved or angled. Deluxe versions may have a $\frac{1}{4}$ -inch square drive end to accommodate interchangeable tips.

Impact screwdrivers are used to remove and install fasteners where hand or wrench torque is insufficient (Figure 26). The drive mechanism of the impact screwdriver converts the impact force of a hammer blow to rotational torque. This torque is transferred to the screwdriver tip. The end of the impact screwdriver is designed to accept a variety of tips.

FIGURE 26—This illustration shows a typical impact screwdriver.



When using the impact screwdriver, always

- Use the correct size bit
- Use a bit that was designed for impact use
- Use eye protection
- First install the tip onto the fastener and twist the tool in the desired direction
- Hold the tool firmly and keep the tip squarely on the fastener
- Strike the tool sharply with a hammer

Observe the following rules when you're using any screwdriver.

- Always clean the slot(s) in a screw head before attempting to remove the screw.
- Always hold a screwdriver so the shaft is at a 90° angle to the screw slot.
- Make sure that the screwdriver blade fits a screw slot snugly to prevent slipping and possible damage to the screw and/or screwdriver.
- Never use a screwdriver to cut or remove metal, to punch holes, to pry, or for any other unintended purposes. This could damage the tool and could cause an injury.
- Never hammer on the handle of the screwdriver (except for impact screwdrivers).
- Never use a screwdriver to work on an object that you're holding in your hand. The screwdriver could slip and cause a painful injury. Use a bench vise to support the object that you're working on.

Pliers

Pliers are another commonly used hand tool. There are a variety of different types of pliers. They vary in size and shape, depending on their intended function. Certain pliers are designed for holding or gripping, others are designed for shaping, and others are used for cutting. Some pliers incorporate two or more functions in a single tool. These are referred to as *combination pliers*.

Combination slip-joint pliers are generally used to hold parts when you work on them, or to twist and bend materials (Figure 27A). Combination slip-joint pliers have a slip joint that lets you open the jaws wide to grip large-diameter items. The jaws have gripping teeth. The outside end of the jaw set is for grasping flat objects, the middle is for grasping curved objects such as tubing, and the inside section of the jaw set has wire-cutting edges. Larger combination slip-joint pliers have longer handles to increase leverage.

FIGURE 27—This illustration shows combination slip-joint pliers (A); locking pliers (B); and long nose pliers (C).



Locking pliers are functionally similar to combination slip-joint pliers. Locking pliers are used to get a firm holding grip on items (Figure 27B). Locking pliers can be locked in place to hold parts tightly while keeping both of your hands free. They can function as a small, portable vise. For example, you can use locking pliers to hold two metal parts in position while you install screws, washers, or bolts.

Long nose and needle nose pliers are useful for gripping or twisting small parts and for reaching parts in limited access spaces (Figure 27C). The jaws of needle nose pliers are smaller and thinner than those of long nose pliers. Needle nose pliers allow you to easily move and position parts that are too small to be handled properly with your fingers. We point out here that you can easily damage these pliers by using them for heavy work. The tips of the jaws will break if you apply too much pressure on them.

Retaining-ring pliers are used to spread or compress retaining rings when these rings are being removed or installed. There are two main types of retaining-ring pliers: those used for internal retaining rings (Figure 28A), and those used for external retaining rings (Figure 28B). These pliers are normally either long nose or angle nose to allow for varying access angles. Some models of retaining-ring pliers come with replacement tips. External retaining rings fit into grooves machined in the outer surfaces of shafts. Internal snap rings are used to retain components on the inside of hollow shafts.

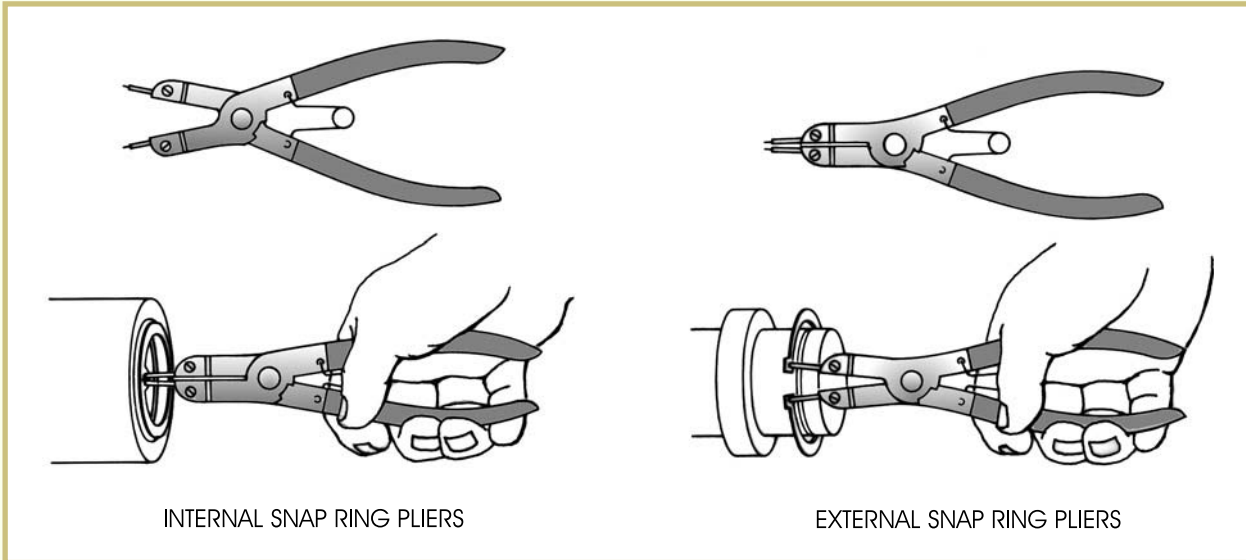

INTERNAL SNAP RING PLIERS

EXTERNAL SNAP RING PLIERS

FIGURE 28—This illustration shows internal retaining-ring pliers (A); and external retaining-ring pliers (B).

The following is a list of some other types of pliers that you may occasionally use:

- *Wire hose clamp pliers* have grooves cut into the jaws to provide positive gripping when removing or installing wire hose clamps.
- *Diagonal cutting pliers* are used to cut wire and to remove cotter pins.
- *Wire stripper/crimper pliers* (commonly referred to as *electrical pliers*) are used to remove insulation from wire and install crimp-type electrical connectors.
- *Snips or shears* are used for cutting sheet metal and metal gasket material. They come in several styles and sizes to match the material being cut.
- *Aviation snips* are used for cutting sheet metal and come in left, right, and straight cutting styles.

Hammers

Motorcycle technicians use a wide variety of hammers in their daily activities that range in size from 2 ounces to 48 ounces. Ball-peen and rubber mallet (or soft-faced) hammers are two of the most common types (Figure 29).

FIGURE 29—The ball peen hammer and rubber mallet are among the most common hammers in a motorcycle technician's tool collection.

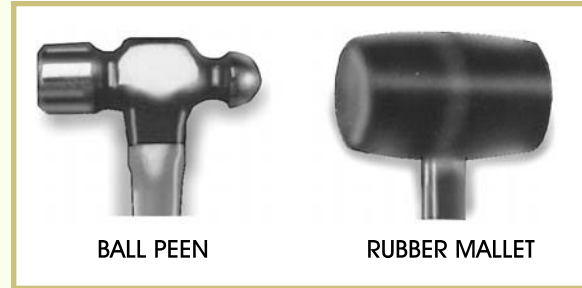

The head of a *ball peen hammer* has two opposing striking surfaces, a flat-faced surface and a rounded surface. The flat-faced surface is used for regular hammering. The ball end is used primarily for shaping cold metal.

You should use a soft-faced hammer if a ball peen hammer might damage the part that you're working on. Several types of *soft-faced hammers* are commonly used in a motorcycle repair shop (Figure 30).

FIGURE 30—This illustration shows several popular soft-faced hammers.

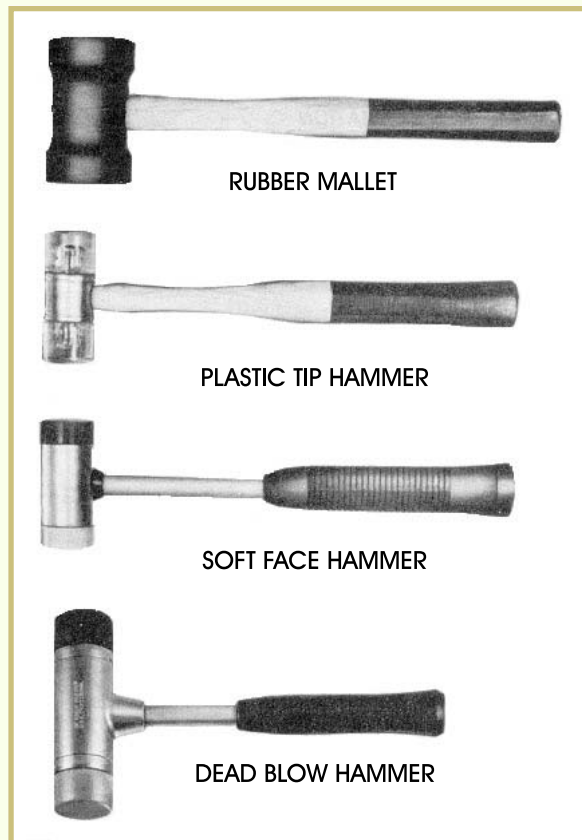

Rubber hammers are used to help seat tire beads and to do sheet metal work. If you're concerned about damaging a part, use a plastic-faced hammer.

Plastic-faced hammers are available with replaceable heads of varying densities (hardness).

Almost all *deadblow hammers* are made from high impact plastic. The plastic shell is filled with lead shot that helps direct the force from the hammer blow and prevents the hammer from bouncing on impact. They're frequently used where a heavy, nondamaging blow is needed, such as installing a bearing.

Here are a few things to remember when using a hammer:

- Make sure that the head is securely attached to the handle.
- Wooden hammer handles should be replaced if damaged. Be sure that the handle fits the hammer head securely. The handle requires the correct-size wedge to properly retain the head.
- You can't repair fiberglass or steel hammer handles. Replace the hammer if the head becomes loose or damaged, or if the handle is cracked.
- Grip the hammer close to the end of the handle to provide better control of the tool and strike a stronger blow.
- Always strike the hammer face parallel with object being hit.
- Always wear safety goggles to protect your eyes.

Punches and Chisels

You'll use an assortment of *punches* when working on motorcycles and ATVs (Figure 31). The assortment usually includes

- *Starting or taper punches*. These punches have tapered shafts with flat tips. They're used to align holes or to start pins moving (Figure 32).
- *Drift (or pin) punches*. These punches have no taper. They have a flat tip and are used to drive out pins. If you use the correct-size drift punch, you won't enlarge the hole and you won't damage the end of the pin.
- *Center punches*. These punches have tempered ends with sharp points. They're used for punching indentation marks in metal. These marks are used as reference points for measuring or as starting points for drilling.

FIGURE 31—This illustration shows examples of the punches used on motorcycles and ATVs.

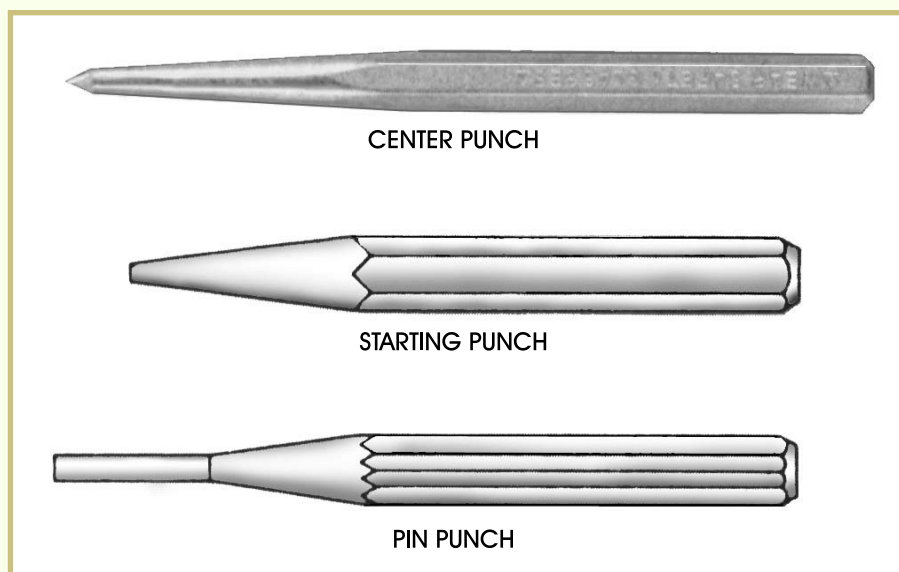
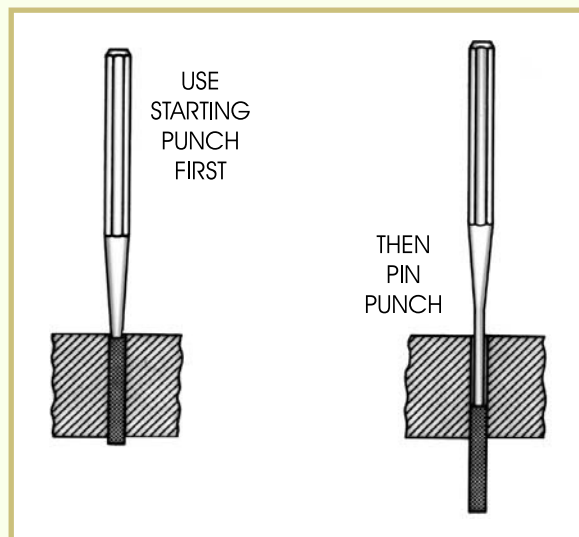

FIGURE 32—The two steps used to remove a pin are shown here.



Here are a few things to remember when using a punch:

- Hold the punch with a firm, but not overly tight grip.
- Hold the pointed end of the punch in place while striking the other end with a ball peen hammer.
- Strike the end of the punch squarely.
- Always wear approved eye protection when using punches.
- The ends of punches wear or get misshapen with use. When the end surface enlarges beyond its normal size or mushrooms, you should grind the bit end back to its original shape.

Chisels are another of those often misused and abused tools! They're not meant for opening paint cans, tightening or loosening screws, or prying things apart. Unfortunately, more than one chisel met an early end trying to perform one of these unintended functions! Chisels are meant to be used for cutting, shearing, and chipping.

The *flat chisel* is the most common type of chisel used in a motorcycle and ATV repair shop (Figure 33). The chisel has a bevel on both sides of the cutting edge. Like the punches that we just covered, the striking head on the chisel is softer than the cutting edge. Here are a few things to remember when using a chisel:

FIGURE 33—This illustration shows several different types of chisels.

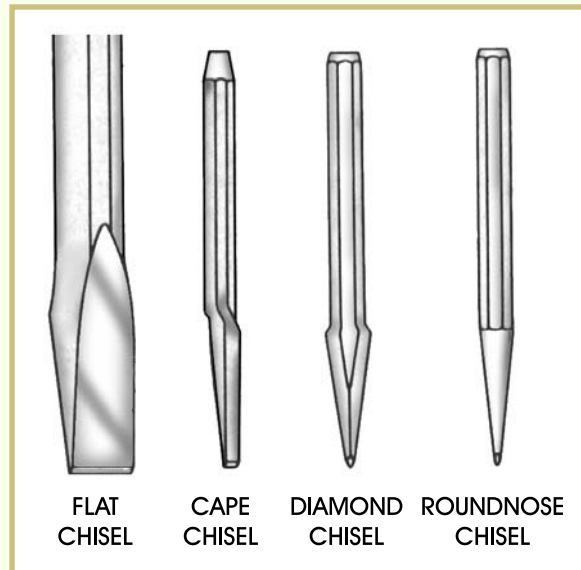

- The chisel head diameter should be approximately one half the diameter of the hammer head that you use for striking the chisel.
- Hold the chisel the same way you would hold a punch. Don't hold it too tightly, but use a firm grip.
- Chisels wear with use. You should grind the head when it shows signs of mushrooming.
- Always keep the cutting edges of chisels sharp. Grind the cutting edges to the original contours and angles.
- Always wear approved eye protection when using chisels.

Clamps and Vises

Clamps and *vises* are used to hold work pieces securely. This frees up both of your hands so that you're better able to handle tools. Clamps and vises are often referred to as an extra pair of hands. Proper and timely use of a vise or clamp can help prevent injuries and eliminate damage to expensive parts and components. If you're ever in doubt

as to whether or not you should use a vise, use it! It only takes one slip or accident to make you wish you did.

C-clamps are basically portable vises that you can use to hold pieces of material together while you work on them. C-clamps are available in a variety of sizes to accommodate a wide range of applications. Most motorcycle repair shops have a collection of C-clamps, with multiples of each size.

The *bench vise* is a useful holding device that clamps onto a workbench or table edge. The underside of the bench vise usually has a heavy-duty C-clamp to secure the vise to the bench or table. This allows you to move the bench vise from one workbench or table to another. This is handy for bringing the vise closer to your work. The jaws of the vise are operated by turning the handle. The jaws are usually covered with soft metal. This covering protects the piece being held in the vise from scratches and dents.

Cutting Tools

Hacksaws are used to cut metal stock that's too heavy to be cut with snips or cutting pliers (Figure 34). Hacksaws are available with adjustable frames to accommodate different-length blades. A wing nut on the blade retention bracket is used to tighten the blade to the correct tension. An improperly tensioned blade doesn't cut well, and dulls quickly.

FIGURE 34—This illustration shows a standard hacksaw.

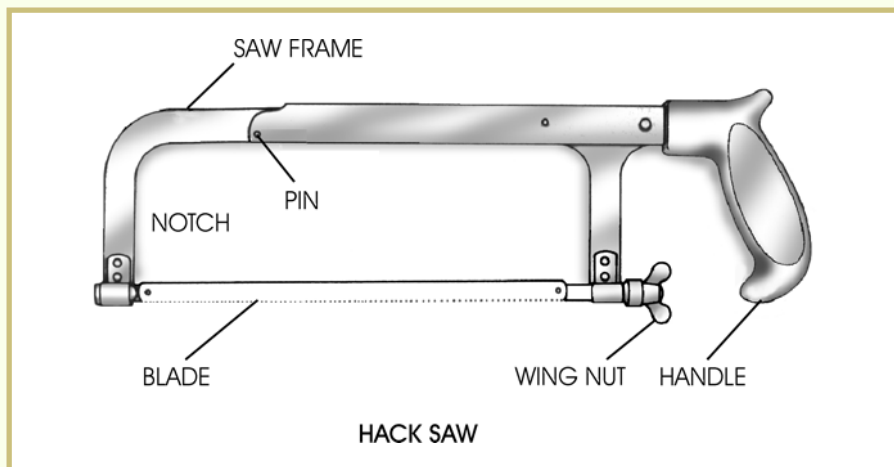

Hacksaw blades are available in a variety of lengths, hardnesses, and tooth patterns for cutting different materials. Generally speaking, harder and thicker materials require coarser, harder hacksaw blades. When using a hacksaw, it's important to apply pressure only on the forward stroke. Use little or no pressure on the back stroke.

Files are cutting tools used to smooth surfaces and edges. Files are classified by their cross-sectional shapes and by the types of teeth (Figure 35). The main parts of the file are

- The tang
- The heel
- The face
- The point

FIGURE 35—The basic parts of a file and several common file surfaces are shown here.

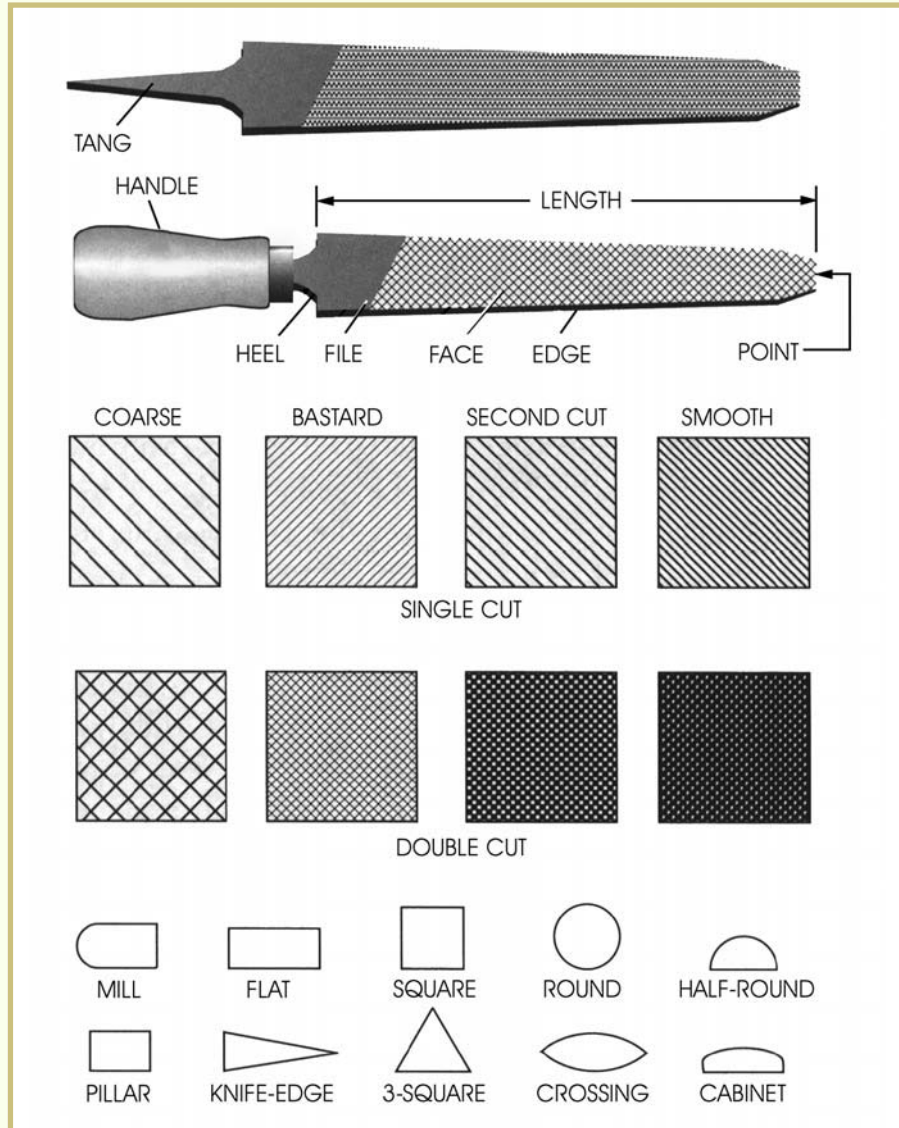

Taps and dies are used to cut threads in metal stock. A *tap* cuts “female” threads (equivalent to the threads in a nut). A *die* cuts “male” threads (like the threads on a screw or bolt). There are different types of taps for various uses (Figure 36). The tap is turned using a special wrench called a *tap wrench* (Figure 37). Dies are turned using a *die stock*.

FIGURE 36—This illustration shows three basic types of taps.

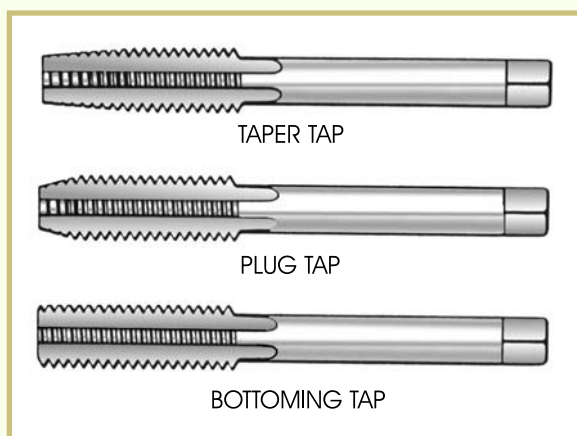
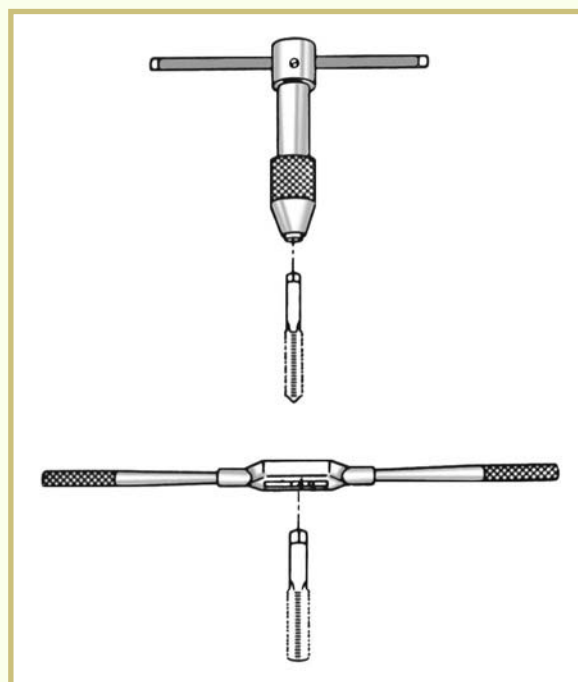

FIGURE 37—This illustration shows two types of common tap wrenches.



Here's a quick overview for using taps and dies. To use a tap, insert the proper-size tap into a predrilled hole in the metal stock, and screw in the tap until it stops. To use the die, clamp the bolt or screw stock into a vise, and screw down the die to cut the threads (Figure 38). Note that the actual use of these tools is complex, precision work that requires skill and experience. We've simplified the description so that you can distinguish between using a tap and using a die.

The *screw extractor* is a tool that's similar in operation to the tap and die. If a bolt or screw head has been accidentally sheared off, you can use a screw extractor to remove the screw. To use a screw extractor, start by drilling a small hole in the center of the broken screw. Then thread the screw extractor into the hole and twist it in a counterclockwise direction. The screw extractor self taps into the broken screw. Continue turning in the counterclockwise direction and the broken screw or bolt will be extracted.

FIGURE 38—This illustration shows the use of a die to cut threads.

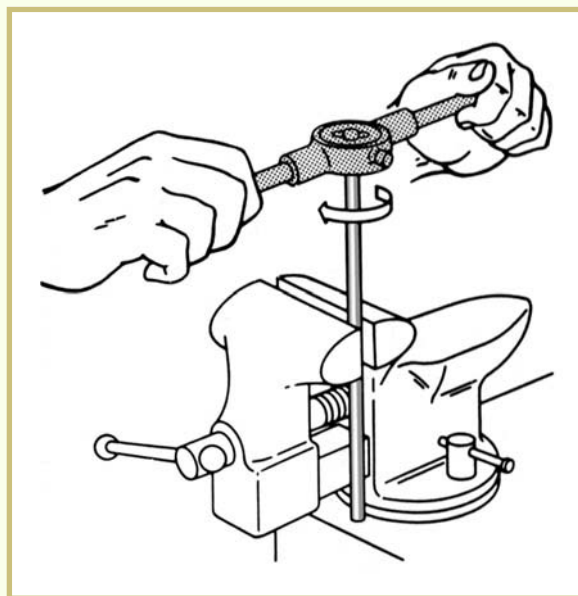

Power Tools

Power tools are essential to the motorcycle and ATV technician. The proper use of power tools will help to make you more efficient at your job. You must exercise extreme care when using power tools. Not only can they cause severe injuries (which we'll cover soon in the section on safety), they can also break fasteners, warp covers, strip threads, and permanently damage components. The power-operated hand tools that we'll cover are either driven by air pressure or powered by electricity.

Drills

One of the more common power tools is the drill. A *power drill* (sometimes referred to as a *drill motor*) is a handheld device that's used to drive a drill bit. The *drill bit* is the tool that bores through the material. The end of the bit that attaches to the power drill is the *shank*, and the power drill's socket that holds the drill bit is the *chuck*.

Power drills come in a variety of speeds. Speed is measured in *rpms* (*revolutions per minute*). You should consider rpm values before selecting a drill. Lower-speed drives are well suited for drilling large holes in certain types of metal. Higher-speed drives are better for drilling smaller holes. Drills with lower rpm values are often equipped with gripping handles. These handles are necessary because of the high rotational torque produced by these tools. Some drills are equipped with variable-speed motors that are controlled by movable triggers. These variable-speed drills are very handy for day-to-day use. Many drills also have a reverse feature that allows you to back a drill bit out of the material you're drilling.

Power drills come in two common shop sizes, $\frac{1}{2}$ and $\frac{3}{8}$ inch. These measurements refer to the maximum diameter of the drill bit shank that the chuck will accept. The larger $\frac{1}{2}$ -inch power drill is used for special low-speed, high-torque situations. The $\frac{3}{8}$ -inch drill is more commonly used for general-purpose applications in the shop.

Drill bits are manufactured from hardened steel rod stock. Drill bits are available in a variety of shapes and lengths. They're frequently sold in graduated-size sets, but each size is available separately. Drill bits are available in both SAE and metric sizes. A well-equipped repair shop has at least one complete set of each.

The drill bits used in a handheld power drill are the same as those used in a shop-style drill press. You must consider the type and thickness of the material you'll be drilling, and the type and size of power drill you'll be using when making a drill bit selection. Not all bits are made for cutting metal. Some are made for wood, plastics, and concrete.

Here's a safety tip when drilling metal. When the bit starts to break through the other side of the metal, the bit may catch and twist the power drill. That's why you should be sure that the piece you're drilling is properly secured and you have a firm grip on the power drill. This will help avoid damaging the part or the drill, and will reduce the risk of injury.

Rechargeable cordless drills are becoming very popular (Figure 39). These drills are quite powerful and they allow you to work in difficult places without being restrained by an electrical power cord. This is particularly handy if you ever have to work in a remote location where normal power isn't available.

FIGURE 39—This is an example of a cordless drill. (Courtesy of Sears Craftsman)

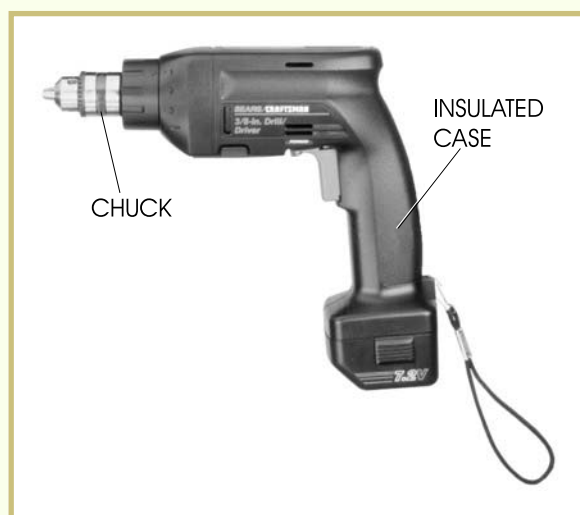

Rechargeable batteries are the power source for cordless drills. A fully charged battery may provide up to several hours of drill usage. Because they must be recharged periodically, you may want to keep

spare batteries handy. That way, when you're busy, the only time you'll lose is the time it takes to swap batteries.

Be sure to read the instruction manual for the proper use and care of these batteries. Some types should be used until they're completely discharged, and other types may be recharged at any time during use. If you recharge the first type before it's completely discharged, the battery will be damaged and its useful life will be shortened.

Always be cautious when using power drills. Be sure to follow these guidelines.

- If you're using corded drills, use only grounded power equipment.
- Determine if there are any obstructions or wiring in the path of the bit before drilling.
- Select the correct drill-and-bit combination to perform the drilling task effectively and safely.
- Don't apply too much pressure on the drill bit.
- Use bit lubricants where required.
- Ensure that the bit is tightly clamped in the chuck.
- Never leave the chuck key in the chuck.
- Use sharp bits. A dull bit could bind, causing the drill to grab. An unexpected twist of the drill could injure your wrist.
- To drill a large hole, start by drilling a smaller hole and gradually increase the hole size by selecting increasingly larger bits.

Drill Press

Another power tool you may need from time to time is the drill press. The *drill press* is a large, floor-standing device that can drill precisely located and angled holes. Because the drill press holds the drill bit in an exact position, it can cut at precision angles and depths. Drill presses use many of the same drill bits that are used with the hand-held power drill.

Bench Grinder

The bench grinder is another useful tool in the motorcycle and ATV service department. The typical *bench grinder* has two rotating wheels, one with an abrasive grinding surface and the other with a buffing wire surface. The wheels can be used to sharpen tools, buff or polish metal, and remove rust from parts.

It cannot be overstated that caution should be used every time you use a bench grinder! Always use eye protection. Always keep a firm

grip on the piece you're grinding or buffing. Finally, make sure that all guards, guides, and shields are in place before you operate a bench grinder.

Air Tools

The *air ratchet* is similar to the standard hand ratchet wrench but is larger than the hand ratchet (Figure 40). The size of the air ratchet drive restricts the places where it can be used directly. With a selected set of shaft extensions and universal joint couplers, the air ratchet can be used for most applications. There are $\frac{1}{4}$ -inch and $\frac{3}{8}$ -inch drive lug models. The air ratchet turns at a much higher speed than a handheld ratchet and lets you remove nuts and bolts more quickly.

FIGURE 40—This illustration shows two different-sized air ratchets. (Courtesy of Snap-on Tool Company, copyright owner)



Power impact wrenches are driven by compressed air or powered by electricity. They come in either $\frac{3}{8}$ -inch or $\frac{1}{2}$ -inch sizes (Figure 41). Power impact wrenches are very useful for component disassembly but aren't recommended for reassembly. It's very easy to apply too much torque using a power impact wrench. The excess torque could easily shear the fastener and/or damage the part or assembly that you're working on.

FIGURE 41—This illustration is an example of a power impact wrench. (Courtesy of Snap-on Tool Company, copyright owner)



As we mentioned earlier, special heavy-duty impact sockets are designed for use with air or impact wrenches. If you recall, they're the ones that normally have a black finish. Here's a handy hint: never start a bolt or nut with a powered impact wrench. The fasteners can cross thread, causing damage to the fastener or component.

Remember to always use approved eye protection when using any power tools. When using compressed-air power tools, never exceed the recommended air pressure rating of the tools.

Special Tools

The basic hand tools that we described are often used to repair motorcycles and ATVs. But many repair activities involve procedures that can't be performed with standard tools alone. You'll need many special tools, especially when rebuilding engines (Figure 42). Special tools are also used to work on brake and suspension systems. As you learn more about motorcycle and ATV repair, you'll discover that a special tool is made for almost every purpose. You should be aware that some special tools are designed to be used on only one make or model of vehicle, while other special tools can be used on a variety of vehicles.

FIGURE 42—Several of the special tools used by motorcycle and ATV technicians are shown here.



We'll be reviewing the names and uses of some special motorcycle and ATV repair tools now. We don't expect you to understand how to use these tools yet. We just want you to become somewhat familiar with them. In later study units, we'll cover the use of specialized tools in detail. Now, let's start our discussion of special tools by looking at some of the more common ones.

Pullers

Pullers are used to safely remove gears, pulleys, and various components from shafts. A puller can easily separate machined parts that are tightly pressed together without damaging the parts. The external

jaws of the puller apply the pulling force, while the center screw presses against the stationary part. Standard pullers have either two or three arms that come in a wide range of lengths (Figure 43). For safety reasons and to protect precision parts, you should use pullers whenever possible to separate parts.

FIGURE 43—Pullers come in various shapes and sizes. (Courtesy of Snap-On Tool Company, copyright owner.)



Precision Measuring Tools

Precision measuring tools are used to make exact measurements of various parts or distances between parts. Measuring tools are used primarily to check for wear of components and specific part-to-part clearances when reconditioning or rebuilding an engine. The measuring instruments used during motorcycle repair can range from standard rulers to precision instruments. They're designed to measure thickness, clearances, pressure, and fastener tightness. Let's take a quick look at some of the common measuring tools.

Micrometer

The *micrometer* is used to measure the size of a part or component. Micrometers come in a variety of sizes and styles. Some micrometers are designed to measure the outer dimensions of an object, such as the diameter of a piston. Other micrometers are made to measure inner dimensions, such as the inside diameter of a cylinder.

To use a micrometer, place the object between the *anvil* and the *spindle*, and then turn the *thimble* until the anvil and spindle contact the object with a light resistance. You can read the measurement on the thimble and sleeve of the gauge (Figure 44).

FIGURE 44—This illustration shows the parts of a micrometer.

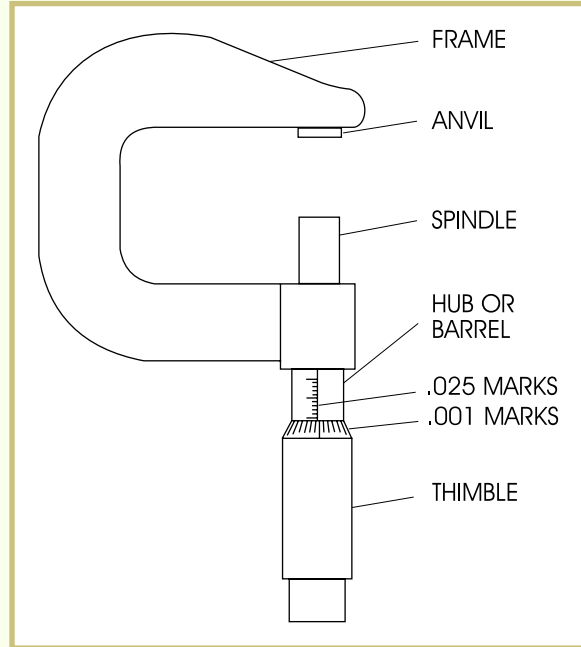

Micrometers are often used during the engine-rebuilding process. During a rebuild, you'll completely disassemble an engine and inspect and measure all of the engine parts to determine if they're worn or damaged. Because the micrometer can measure thickness so accurately, it can easily detect small changes in part sizes that indicate wear. Using a micrometer is a typical procedure performed during engine reconditioning (Figure 45).

Note: Figure 45 shows a micrometer being used to measure a piston. It is worthwhile to mention that exactly where you measure the piston will depend on the particular style of piston.

FIGURE 45—This illustration shows a micrometer measuring a piston.

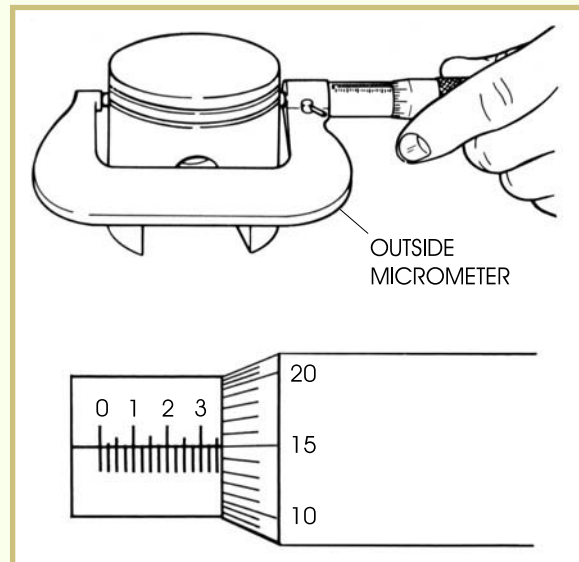

Vernier Caliper

The *Vernier caliper* is one of the most commonly used precision measuring tools in motorcycle repair work (Figure 46). Vernier calipers are quite accurate, but they're less accurate than micrometers. In those cases when exact precision is needed, micrometers should be used.

FIGURE 46—A Vernier caliper is shown here.

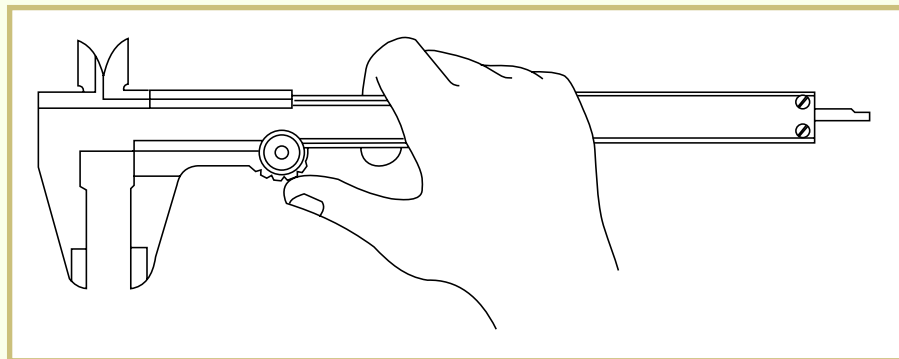

To operate Vernier calipers, slide the jaws of the caliper around the part. The caliper indicates the size of the object on its display scales. You can use the jaws and nips of most sliding calipers to measure both outside and inside dimensions. Individual styles of Vernier calipers display their measurements differently. Some of the more common styles include the printed beam and Vernier scale, the dial gauge, and the digital display.

Our caliper example has a printed beam and Vernier scale (Figure 47). You must read the numbers on the scale and perform some calculations to obtain the actual measurement. In contrast, digital calipers are much easier to use. The caliper displays the true measurement directly on the digital display screen.

FIGURE 47—A typical Vernier scale is shown here.

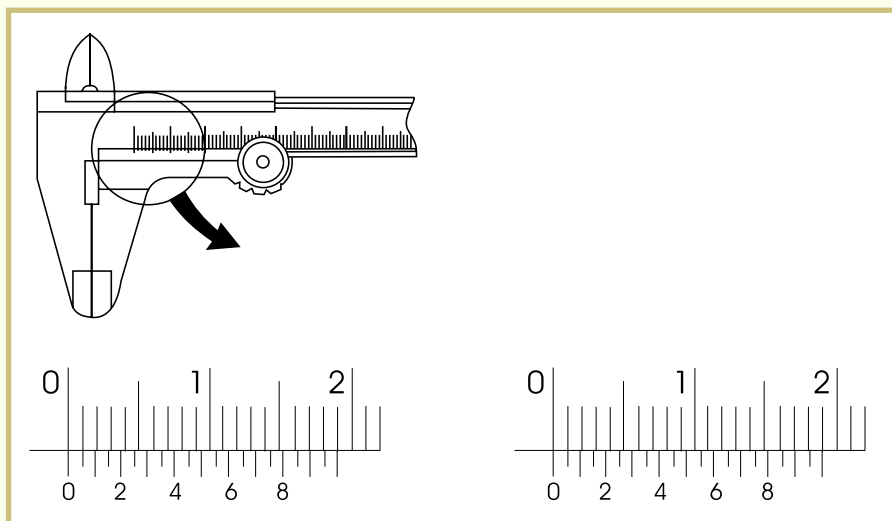

Dial Indicator

So far, we've looked only at tools that measure the sizes of parts. There are times when you'll need to measure the distance that a part moves, such as the in and out movement (travel) of a shaft. The most common way to measure this type of movement is with a tool called a dial indicator. A *dial indicator* is simply a dial gauge with a plunger that sticks out from one side (Figure 48).

FIGURE 48—This illustration shows an example of a dial indicator.

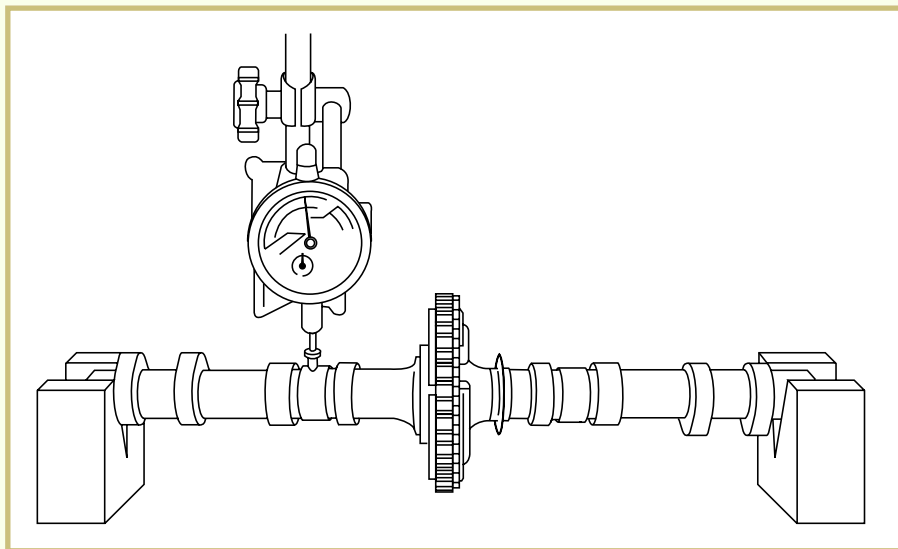

To use the dial indicator, attach it to a solid object (usually by means of a magnetic base) next to the item you're going to measure. Position the dial indicator so that the plunger contacts the object to be measured. Move the object back and forth. The dial indicates the distance that the plunger travels. Dial indicators are often used during engine and transmission rebuilding.

Torque Wrench

Accurate tightening of fasteners is a key consideration in the proper operation of engines and other motorcycle components. In shop repair and service manuals, manufacturers specify the exact amount of torque that should be used to tighten fasteners, such as head bolts. Because it's almost impossible to accurately tighten a bolt by hand to a specified torque, special tools called torque wrenches are used. A *torque wrench* allows you to apply the exact amount of tightening force (torque) to a fastener. Frequently, the torque wrench is a modified socket drive handle that has a torque-measuring device built into it. This allows you to use standard interchangeable sockets when you're setting the torque on fasteners.

A torque wrench contains a measuring dial or scale. As you tighten a nut or bolt with the wrench, the dial or scale indicates how much torque you're applying to the fastener. These scales are usually calibrated in foot-pounds (ft-lb), inch-pounds (in-lb), or Newton-meters (N/m). There are three common types of torque wrenches (Figure 49).

FIGURE 49—The three most common torque wrenches are shown here.

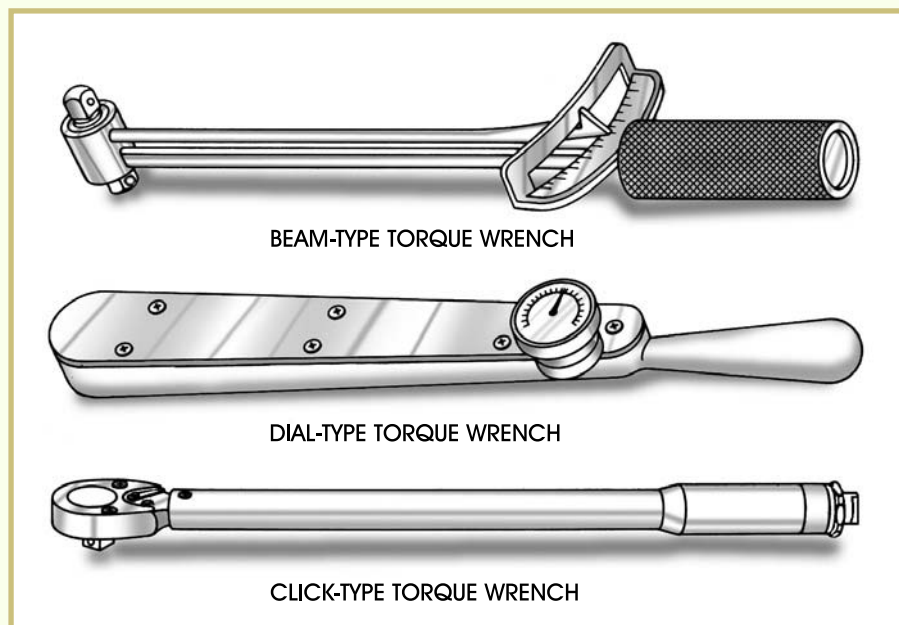

The *beam-type torque wrench* contains a metal pointer rod. As you tighten a bolt, the rod points to the measured torque value.

The *dial-type torque wrench* displays the amount of torque on a display dial. As you tighten the fastener, watch the dial until the desired torque value is reached.

The *click-type torque wrench* is somewhat easier to use than the beam-type or dial-type. With a click-type torque wrench, you preset the desired amount of torque on a calibrated dial before tightening the bolt. When you reach the preset torque value, the wrench clicks and no more torque is applied to the fastener.

Feeler Gauge

Feeler gauges are another type of measuring tool. Feeler gauges are typically used to measure very small spaces between two parts, such as spark plug gaps. These small spaces are often called *clearances*. A typical feeler gauge is actually a set of gauges, made up of a large selection of metal blades that can spread open like a fan (Figure 50). The blades vary in thickness to provide a complete range of very precise measurements. Each blade is marked with its thickness, in some cases marked in both metric and SAE sizes.

FIGURE 50—A typical set of feeler gauges is shown here.

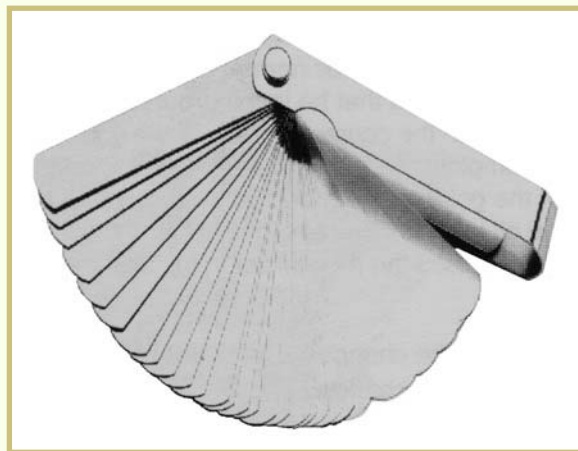

To measure the distance between two parts, insert one blade at a time between the parts until you find the blade that's an exact fit. The marked size of that blade indicates the measured clearance between the two parts. In some cases, a combination of two or more blades is used to precisely measure the clearance. In those cases, you must add the total of the blade thicknesses to determine the clearance.

Test Instruments

Troubleshooting and repairing motorcycles requires a wide variety of special test instruments. These test instruments are designed to test the condition of various systems. For example, there are several different instruments that you can use to test an engine's ignition and electrical systems. Other testing devices are used to measure compression and pressure. Let's take a brief look at some of the more common test instruments.

Multimeter

You can use several different special instruments to test or measure electrical circuits within a motorcycle's electrical system. The most common electrical testing instrument is the *multimeter* (also called a *volt-ohmmeter* or VOM). This one instrument can measure voltage, current, and resistance.

The multimeter is a box-like device that has two flexible wire test leads connected to it (Figure 51). The ends of the wire leads hold probes that are used to contact the electrical circuitry. The probes can be either needle-point or alligator-clip design. Most are a combination to allow you to either probe, or connect the test leads, depending on what component is being tested.

FIGURE 51—A multimeter is a valuable tool for finding electrical problems.

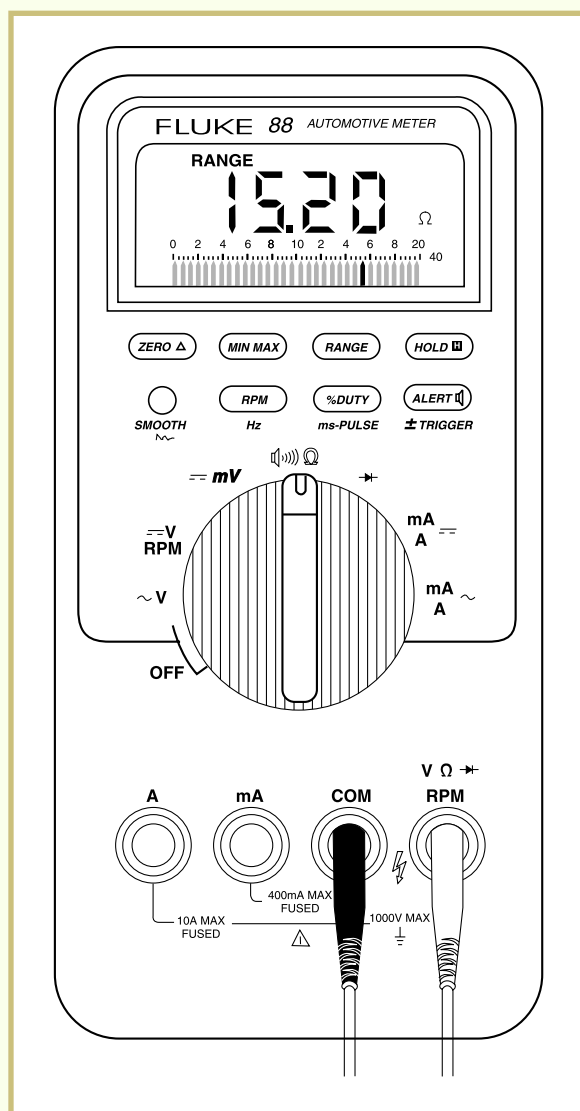

The probes are touched to different areas of an electrical circuit to make electrical measurements. The multimeter has a display face to provide the circuit measurement information to the user. The display can be either a moving needle or a digital display. The circuit information displayed by the multimeter helps you determine where problems such as broken wires, faulty connections, or defective components may exist in an electrical system.

Note that this is a very brief and very basic description of the multimeter's operation. The actual operation of a multimeter is much more complex. You must always observe electrical-safety precautions when using the multimeter. You could damage the multimeter and the electrical circuit if you use it improperly. More importantly, you could receive a severe electrical shock. We'll discuss in detail how and where to use a multimeter in a later study unit.

Timing Light

In simple terms, an engine's ignition system sends controlled electrical impulses to one or more spark plugs, causing the spark plug(s) to fire. The timing of the plug firing is very important to efficient engine operation. You can use a special device called a *timing light* to determine if the timing of the spark impulse is correct.

The timing light is usually connected between the spark plug and the ignition system. To use this type of timing light, you connect it between the spark plug and the plug wire, start and run the engine, and watch the timing light flash against the rotating timing mark. Each time the spark plug fires, the timing light will produce a flash of light (strobe) that freezes the mark. The illuminated timing mark is compared with a fixed reference mark to verify correct timing. If the timing is wrong, the two marks (fixed and rotating) will not line up. You then adjust the timing until the marks come into alignment.

Tachometer

A *tachometer* is an instrument that's used to measure engine *rpm* (*revolutions per minute*). The tachometer is connected to an engine's ignition system to count the number of ignition pulses. Modern tachometers often have clamp-on leads that fit over engine spark plug wires. This type of connection is called an *inductive pick-up*. The tachometer converts the count of ignition pulses to an rpm reading. You'll use the rpm reading during engine tune-ups and for problem analysis.

Gauges

The *tire pressure gauge* is used to measure the amount of air pressure in a tire. Proper tire pressure is an important factor in vehicle handling, safety, and tire wear. Tire pressure gauges come in a variety of styles from the simple pencil-type gauges to electronic digital-display gauges. To use a tire pressure gauge, place the gauge over the tire valve stem and press the gauge inward. The tire pressure is displayed on the gauge.

The *compression tester* is used to measure pressure in an engine cylinder. A mixture of air and fuel is compressed inside of the engine's cylinder before the mixture is ignited. The higher the cylinder compression, the better the fuel mixture will burn. As engine components wear, the compression in the cylinder will decrease. By measuring the cylinder's *compression stroke pressure*, you can determine if the engine parts are worn sufficiently to require an engine rebuild.

To use the compression tester, unscrew the spark plug from the cylinder head and install the compression tester gauge adapter into the cylinder head in place of the spark plug. When you turn the engine through a compression stroke, the amount of pressure that's developed in the cylinder is displayed on the gauge.

The *vacuum gauge* is another gauge used to measure pressure. A vacuum is developed in the cylinder during the *intake stroke*. This vacuum draws the air-and-fuel mixture into the cylinder. The correct amount of vacuum is needed for the engine to perform properly. A weak vacuum may indicate an internal problem with the engine, such as worn piston rings or cylinder(s), incorrectly adjusted carburetors, and stuck or worn valves. You can measure the amount of vacuum produced during the intake stroke with a vacuum gauge. A vacuum gauge has a rubber hose attached to it. To use the gauge, attach the hose to the engine between the engine and carburetor. Start the engine and read the gauge. The amount of vacuum in the engine is indicated on the gauge. Vacuum gauges are used on multiple-cylinder engines primarily to synchronize and balance the carburetors.

An *exhaust analyzer* is used to measure the levels of certain gases in an engine's exhaust. Most modern exhaust analyzers are designed to measure the levels of hydrocarbons and carbon monoxide in the exhaust. The word *hydrocarbons* refers to raw, unburned fuel in the exhaust. *Carbon monoxide* is a toxic, odorless gas that's produced when fuel doesn't burn completely in an engine.

To analyze an engine's exhaust, insert the exhaust analyzer probe into the tailpipe to sample the exhaust gas. The analyzer will produce readings that indicate the levels of various gases in the exhaust. You can compare these readings with an analyzer diagnostic chart to make an analysis of the engine's condition. If the engine is working properly, certain percentages of each of the gases will be present in the exhaust. If the level of a particular gas is higher or lower than normal, it may indicate a problem with the engine or fuel system.

Besides being used for diagnosing engine problems, a vehicle's exhaust may also be analyzed to ensure that it complies with federal emission laws. These emission laws define the amounts of pollutants that motorcycles can legally release into the environment. All new street motorcycles must meet specific exhaust requirements defined by the federal government.

Purchasing Tools

Very few motorcycle technicians own every type of available repair or diagnostic tool. This is true because most technicians don't perform every type of repair. Just what tools you'll need depends on your repair specialty area and the availability of equipment at the service department where you work. In most motorcycle service departments,

technicians are required to buy their own basic hand tools and possibly some simple diagnostic tools. But specialized tools and expensive test equipment are usually provided by the service department.

When you buy tools, remember that you'll use these tools almost every day. You must be able to depend on them. For this reason, the tools that you buy should be of high quality to provide you with many years of service. It's a very good idea to buy professional-quality, brand-name tools. These tools are usually of the highest quality and are often backed with lifetime warranties. This means that the tools should provide quality service for your entire working lifetime. If a tool under warranty is damaged or fails in normal use, you can return it to the manufacturer for a replacement.

You can purchase most tools individually or in sets. If you intend to enter the motorcycle repair field, you may want to consider purchasing a complete starter set rather than dealing with individual tools. In most cases, purchasing tools in sets is less expensive than buying them individually. But if you already own a reasonable assortment of quality tools, you may need to purchase only a few additional items to meet your tool needs. A basic motorcycle technician's tool kit was shown earlier in [Figure 13](#). You may want to refer back to it and study the figure to ensure that you can identify the contents of the kit. The kit contains most of the basic tools that you'll need to work in a motorcycle service department or in your own garage.

As you gain experience and start performing more repairs, you can add more tools to your starter set. Remember that it's better to avoid buying too many tools until you're reasonably established in your field. Before purchasing an assortment of tools that you may never use, stop and analyze your situation. When you determine the types of repairs that you'll be doing routinely, you can purchase extra tools based on your specific needs. This planning will help you avoid spending a lot of money on tools that you may never need in the future. Tools aren't cheap, but they're a sound investment in your future. Invest wisely!

Storing Tools

Proper tool maintenance and storage should be an important part of your daily routine. Professional technicians always take proper care of their equipment. Because you'll probably own a large collection of tools one day, it's very important to establish good work habits and house-keeping practices early in your career. One of the most important first steps is to organize your tools so that you can find them easily. You don't want to spend a lot of time looking for a tool each time you need it.

And equally important, tools are an expensive investment. You should keep them locked up when you're not using them. The best way to store and organize your tools is to keep them locked in a sturdy,

professional-quality toolbox. Toolboxes come in a variety of sizes and price ranges. They can be small and portable (Figure 52), or large, floor-standing units with wheels (Figure 53).

FIGURE 52—A typical portable toolbox is shown here. (Courtesy of Snap-On Tool Company, copyright owner)

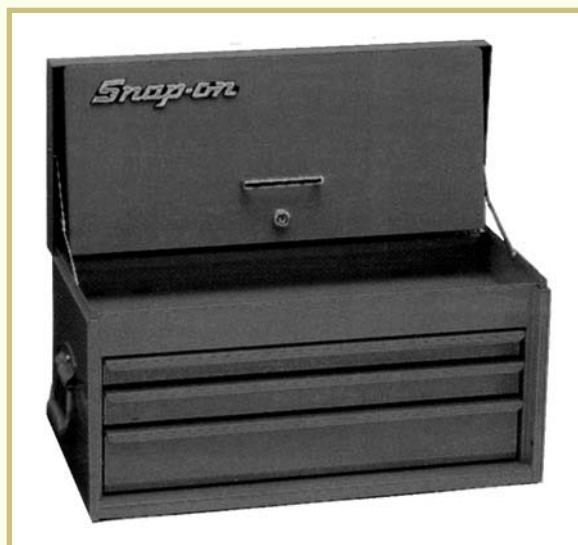
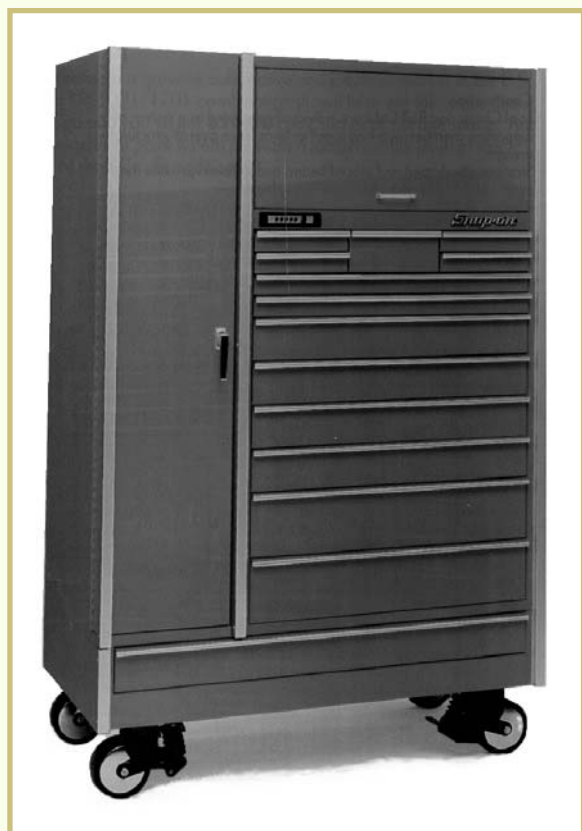

FIGURE 53—A large, freestanding floor tool cabinet is shown here. (Courtesy of Snap-On Tool Company, copyright owner)



When choosing a toolbox for storage, always consider your future needs and plan ahead! As a professional technician, you'll continue to add tools to your collection as the need arises. So, when you choose a toolbox or cabinet, select one that will allow room for future expansion.

Service Manuals

Whenever you're repairing or rebuilding a motorcycle or ATV, the correct service manual is a must. Because each make and model has slight differences, you'll frequently need to look up manufacturer's information and specifications about the particular vehicle you're working on. Up-to-date service manuals are as essential to your work as the proper tools. Most franchised motorcycle dealerships are required to keep a variety of reference books and service manuals on hand. These collections of service documentation grow every time new models and features are introduced to the market. Service manuals contain a variety of helpful information, such as

- Engine identification information
- Engine specifications
- Reconditioning specifications
- Recommended repair procedures

The term *specification* can be defined as a detailed and exact statement of particulars, especially a statement prescribing materials, dimensions, and workmanship for something to be manufactured, installed, or rebuilt. Our usage of the term focuses on certain precision measurements made on parts of the vehicle, particularly in the engine. The exact measurements are determined by the manufacturer and are listed in the vehicle's service manual.

When you're doing a major rebuild of a motorcycle engine, many of the engine specifications must be checked with precision measuring instruments. These measurements are compared with the specifications listed in the service manual. Any deviations from the listed acceptable tolerance limits indicate a problem that should be corrected as part of the repair process. An engine must conform exactly to its specifications to operate properly. Some common engine specifications include

- Spark plug gap (the width of the gap between the spark plug's electrodes)
- Cylinder-bore (the inside diameter of the engine's cylinder)
- Torque requirements (tightness of fasteners, usually measured in foot-pounds)

Some technicians will attempt to make repairs to a vehicle without using service manuals, but this isn't a good practice for several reasons.

First, even the most experienced technicians can't remember every specification for every make and model vehicle. If you were to work on only one motorcycle make and model, you could probably handle most repairs without the use of outside references. But in almost all service departments, technicians work on a large variety of models from many different manufacturers.

Secondly, manufacturers make changes and improvements to their vehicles from year to year. Each year, more new vehicles are introduced and more features are added to existing models. Up-to-date service literature will help you stay current with the latest changes to the vehicles you service.

And finally, manuals are often necessary in those cases where you weren't the person who disassembled a particular component. You may be picking up the handiwork of someone else. With a service manual at hand, you can quickly determine how the component should be assembled and how it should be adjusted once it's installed.

Service manuals are useful tools, but they can't tell you everything. Most manuals are written with the assumption that you already know the basics of motorcycle repair, such as

- How engines operate
- How the various motorcycle systems operate
- How to disassemble and reassemble engines
- How to use the proper tools and measuring instruments

Most service manuals concentrate on specifications and repair procedure sequences. Therefore, service manuals can never take the place of good training. Service manuals are simply additional tools to help you make repairs correctly and efficiently.

Road Test 3

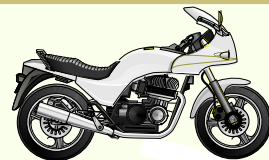

Fill in the blanks in each of the following statements.

1. A _____ is a test instrument that's commonly used to measure volts, ohms, and other electrical measurements.
2. Motorcycle tools can be classified into these three categories: _____ _____ _____.
3. A _____ is used to tighten a nut or bolt with the exact required amount of pressure.

(Continued)

Road Test 3

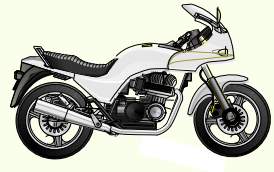

4. One of the most commonly used precision measuring tools in motorcycle and ATV repair is the _____.
5. The _____ measuring system uses millimeters.
6. A flare-nut wrench is commonly used for _____ or _____.
7. A short, six-sided rod used to tighten screws with similar indentations is the _____.
8. Which is a better choice in tight places?
 - a. 6-point box wrench
 - b. 12-point box wrench
9. *True or False?* An air ratchet is suitable for tightening fasteners.

Check your answers with those on page 79.

KEY SAFETY ISSUES

The Safety Attitude

Most people are concerned with safety in and around their homes. They strive to protect their families from accidents and injuries. But accidents in the workplace are often much more severe than home accidents, because workplaces contain many more potential hazards than the average home.

Safety is more than just the absence of accidents. *Safety is an attitude* that helps you prevent injuries to yourself and others. Safe working practices should be a way of life. They should be as instinctive as putting on your seat belt or looking both ways before you cross the street. Safety isn't a matter of good luck or bad luck. It's a predetermined set of mental exercises, including

- Planning to work safely
- Recognizing potential safety hazards and eliminating them
- Following proper safety procedures at all times, especially at work

You should be aware that the *Occupational Safety and Health Administration (OSHA)* is the federal agency that publishes safety standards for business and industry. The OSHA regulations affect every business that has employees and sells its products or services. OSHA requires every employer to provide employees with safe workplaces that are free from recognized hazards. Without getting into a long discussion about the legal aspects of OSHA, suffice it to say that it's the

federal government's law enforcer for industrial-safety matters. Employers are motivated to adopt and use safe working procedures through OSHA's strict enforcement of the regulations. Safety violators receive harsh penalties and fines.

You can find a complete list of OSHA's proven safety methods, practices, and regulations in one convenient resource called the *Code of Federal Regulations*. Even if you're a one-person operation, you should understand and follow OSHA's safety guidelines for your own protection. In a motorcycle service department, the safety matters of primary concern are

- Fire safety
- Chemical safety
- Basic electrical safety
- Ventilation of exhaust gases
- Safe operation of engines and equipment
- Good housekeeping practices
- Safe handling of heavy objects and materials
- Safe use of stands and lifts
- Proper use of personal protective equipment
- Safe riding practices

Now that we've provided you with a quick list of the safety topics and areas that OSHA's regulations cover, let's look at these important safety items one at a time.

Fire

A major safety consideration in the motorcycle repair business is fire prevention. Many fires occur in private garages every year and a significant number of these are started by the mishandling of gasoline, such as storing gasoline in unapproved containers or failing to clean up gasoline spills. Gasoline is the fuel for almost all motorcycle engines. Because gasoline is one of the most flammable liquids, fire is a serious threat in any motorcycle service area.

Gasoline isn't the only flammable liquid used in the service department. Oils, lubricants, paints, cleaning solvents, and other chemicals can also create a fire hazard when improperly handled. Despite the fire risk, a service department can be run safely. By following basic safety practices, the danger of fire can be greatly reduced, if not eliminated entirely.

The *National Fire Protection Association (NFPA)* is the largest and most influential national group dedicated to fire prevention and protection. Its mission is to safeguard people, property, and the environment from fires. The NFPA also publishes the *National Electrical Code (NEC)*. The NEC is the national standard for all residential and industrial electrical installations in the United States and Canada. When you start planning a fire safety program for your business, check with the NFPA. They can provide useful hints and detailed support information.

The Fire Triangle

There are three conditions that must be present for a fire to start. These conditions are grouped together to form the *fire triangle*. The three components of the fire triangle are

- Fuel (such as wood or gasoline)
- Oxygen
- An ignition source (such as a spark)

After a fire starts, the supply of fuel and oxygen must stay at certain levels to sustain the fire. To extinguish a fire, you must remove at least one of these two legs of the fire triangle. You can put out a fire by removing the fuel source or removing the oxygen.

When analyzing fire prevention, you must always be aware of the ignition sources that could start a fire in your work area. When we consider ignition sources, most of us think of open flames, sparks, stoves, and matches. However, there are several other dangerous, but less obvious, ignition sources.

For example, a common but often overlooked source of ignition is the engine exhaust. A motorcycle's exhaust system becomes very hot during operation. This heat remains in the exhaust system for a period of time after the vehicle's engine has been turned off. Therefore, if a vehicle's engine is still warm when you begin to make repairs, you must take extra precautions to prevent fires.

Another highly possible source of ignition is cigarette smoking. Smoking-related ignitions are a leading cause of fires. Sparks from lit cigarettes, heat from discarded cigarette butts, and the open flames of lighters and matches can all start fires in flammable and combustible materials. Therefore, smoking should be strictly controlled in your service department. Smoking and nonsmoking areas should be posted with distinct, easily recognizable symbols. Smoking areas should be equipped with adequate receptacles to provide for the safe disposal of smoking materials. Smoking is prohibited in many service departments, and smokers must go to a designated outside smoking area.

Spontaneous combustion is another potential source of ignition that you should recognize. In *spontaneous combustion* fires, the heat for ignition is created by a chemical reaction in combustible materials. One common type of spontaneous combustion occurs when oil- or solvent-soaked rags or papers are discarded in a trash can. The decomposition of the oil or solvent often produces enough heat to ignite the rags or papers. To prevent spontaneous combustion, all oil- or solvent-contaminated rags and papers should be discarded only in designated, fireproof metal safety receptacles. Routine trash material shouldn't be discarded in these special receptacles.

The Four Fire Classes

Let's take a closer look at the different types of fires. The NFPA classifies fires in four categories, or classes: Classes A, B, C, and D. Each of these fire classes is defined by, and associated with, a different type of fuel source.

Class A fires involve the burning of wood, paper, cardboard, fabrics, and other similar fibrous materials. These materials ignite easily, burn rapidly, and produce large quantities of heat during burning. Some examples of Class A combustible materials that are commonly found in workplaces include

- Business forms
- Company files or records
- Cleaning and polishing cloths
- Work aprons
- Dust covers
- Work area partitions

Class A fires can be extinguished with water, CO_2 (carbon dioxide), or dry chemical agents. These agents extinguish the fire by quickly cooling the burning material and lowering the temperature in the combustion zone. The symbol used to identify Class A extinguishing equipment is the letter "A" inside a green triangle (Figure 54).

FIGURE 54—These are the symbols placed on fire extinguishers to indicate the types of fires that the extinguishers are to be used on.

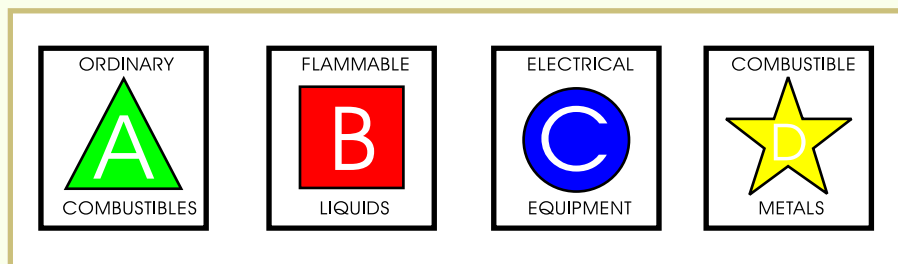

Class B fires involve flammable liquids, gases, and other chemicals. Because many flammable and combustible liquids and solvents are used in a motorcycle service department, special care should be given to

their handling, use, and storage. Some common flammable liquids include gasoline, cleaning solvents, oils, greases, turpentine, oil-based paints, and lacquers. Common flammable gases include natural gas, propane, and acetylene.

Fires involving flammable liquids produce tremendous quantities of heat. Water is an ineffective extinguishing agent for a Class B fire. The heat from a burning flammable liquid will boil the water that's applied to the fire, turning the water into steam before it can do much good. Most importantly, almost all flammable liquids are lighter than water. The liquids float on top of the water and continue burning. This is a very dangerous situation that can cause a flammable liquid fire to spread very rapidly. The best way to extinguish a Class B fire is to smother it, removing its source of oxygen. Foams, dry chemicals, and CO₂ are the best extinguishing agents to use on a Class B fire. The symbol used to identify Class B extinguishing equipment is the letter "B" inside a red square (Figure 54).

If you routinely keep gasoline (even in small amounts) in your shop, you should have at least one Class B fire extinguisher in the area. You can also smother a small Class B fire with a blanket or non-combustible container. Use this method only if you can do so without risking personal injury. You should always remember that flammable liquid fires have a tendency to flare up very rapidly.

Class C fires involve live electrical equipment such as electrical boxes, panels, circuits, appliances, power tools, machine wiring, junction boxes, wall switches, and wall outlets. Electrical fires are usually caused by some form of short circuit, or overloaded circuit. Examples of these causes include

- Loose contacts or terminals
- Frayed wire insulation
- Improper installations
- Defective equipment
- Overloaded circuits

Electrical system overloads and short circuits can produce arcs, sparks, and heat. This type of electrical problem can ignite nearby combustible materials such as wire insulation, plastic components, and wall insulation or paneling.

Warning: Water or water-based solutions must never be used on a **Class C fire**. Water is a good conductor of electricity, and if it's applied to an electrical fire, the person holding the extinguisher could be severely shocked or electrocuted. **Always use dry extinguishing agents such as carbon dioxide, dry chemicals, and Halon on Class C fires.**

Carbon dioxide (CO_2) is the most widely used extinguishing agent because it's nonconductive, it penetrates around electric equipment well, it's effective, and it leaves no residue that would have to be cleaned up afterward. Dry chemicals produce a residue that can damage electric equipment.

Halon is another extinguishing agent that's very effective on all classes of fire, especially Class C. Halon is stored as a liquid under high pressure, and is released on a fire as an oxygen-depleting (smothering) gas. Although Halon is very effective, it's not readily available. Halon is a fluorocarbon compound that's classified as an ozone-depleting substance. The usage of Halon is restricted by law for environmental reasons. The symbol used to identify Class C extinguishing equipment is the letter "C" inside a blue circle (Figure 54).

Class D fires involve combustible metals such as magnesium, titanium, zirconium, sodium, lithium, and potassium. Flakes and fine particles of these metals can be ignited at relatively low temperatures. Metal particles are often produced by cutting or grinding operations. If cutting or grinding is done in the typical motorcycle repair shop, it's usually confined to a designated area that's uncluttered and well ventilated. The larger exposure to Class D fires is found in a "back-of-the-garage" type of operation, where space is limited and conditions might favor the start of this type of fire. You should be aware of Class D Fires, and how to react to them.

Dry powder compounds and *dry chemical extinguishers* are the two primary methods to extinguish Class D fires. Dry powder compounds are completely different than dry chemical extinguishers. Dry powder compounds are usually scooped directly onto a fire. Dry chemical extinguishers apply the dry chemical charge under pressure. The symbol used to identify Class D extinguishing equipment is the letter "D" inside a yellow star (Figure 54).

The most important reason for introducing you to the four classes of fires is to inform you of what to do and what not to do in a fire emergency. Your reaction to a fire could mean the difference between a minor incident and a major loss of property, with possible injury or death. A knowledge of the fire classes is also important when you're assessing your work area for fire hazards. Fire prevention isn't just a slogan from *Sparky the Fire Dog!* Most fires are preventable. Awareness, common sense, and good work habits go a long way towards preventing fires.

Based on the nature of your work environment, the two types of fires most likely to occur in a motorcycle service department are Class A and Class B fires. But don't be negligent about the possibility of a Class C or Class D fire occurring also. Know what to do for all fire classes.

Using a Fire Extinguisher

Fire extinguishers must be properly used to be effective on a fire. You should become familiar with the various extinguishers installed at your facility before a fire starts. This familiarization step is important for the following reasons:

- To operate a fire extinguisher safely and efficiently, you should know how to use it. You'll lose valuable fire-fighting time if you have to stop and read instructions. Be prepared!
- You could injure yourself or others by using an extinguisher improperly.
- An average fire extinguisher discharges all of its contents in only 12 to 60 seconds. You need to make the best use of all of the extinguisher contents.

To be effective, portable fire extinguishers must be readily available in a fire emergency. Extinguishers must be installed close to all potential fire hazards. The extinguishers must contain the proper type of extinguishing agent for those hazards and they must be large enough to protect the designated area. The fire hazards existing in a shop must be identified and evaluated, to verify that the proper numbers and types of fire extinguishers are installed at the correct locations.

Take the following steps before you attempt to extinguish any fire:

1. Evaluate the size of the fire. A fire in its beginning stages is called an *incipient fire*. A fire is classified as incipient (start-up) if it covers an area no larger than 2 – 4 feet square, has flames less than 2 feet in height, and produces low levels of smoke. Fire extinguishers can be effective for extinguishing or suppressing this size of fire. But it's not safe to use a fire extinguisher after a fire passes beyond the incipient stage. The length of time that a fire remains in the incipient stage is usually quite brief. If the fire goes beyond the start-up stage, the only course of action is to evacuate the building or facility and call the fire department.
2. Locate the exits and the escape routes you'll need in an emergency evacuation. To prevent yourself from becoming trapped in a serious situation, keep the locations of the exits in mind as you fight the fire.
3. Determine which way the flames are moving and approach the fire from the opposite direction. The flaming side of the fire radiates too much heat, and the fire could overtake you before you have a chance to escape. By attacking the fire from the opposite side, you'll be safer and you'll be able to get closer to the combustion zone of the fire.

When you've taken these preliminary steps, you're ready to use an extinguisher (Figure 55). To operate this type of extinguisher,

1. Remove the extinguisher from the wall.
2. Grasp the handle of the extinguisher and pull out the safety pin.
3. Free the hose and aim the nozzle at the fire.
4. Squeeze the handle.
5. Move the nozzle in a sweeping motion to distribute the extinguishing agent.

FIGURE 55—The basic parts of a typical fire extinguisher are shown here. The label lists the classes of fires that the extinguisher is to be used on.

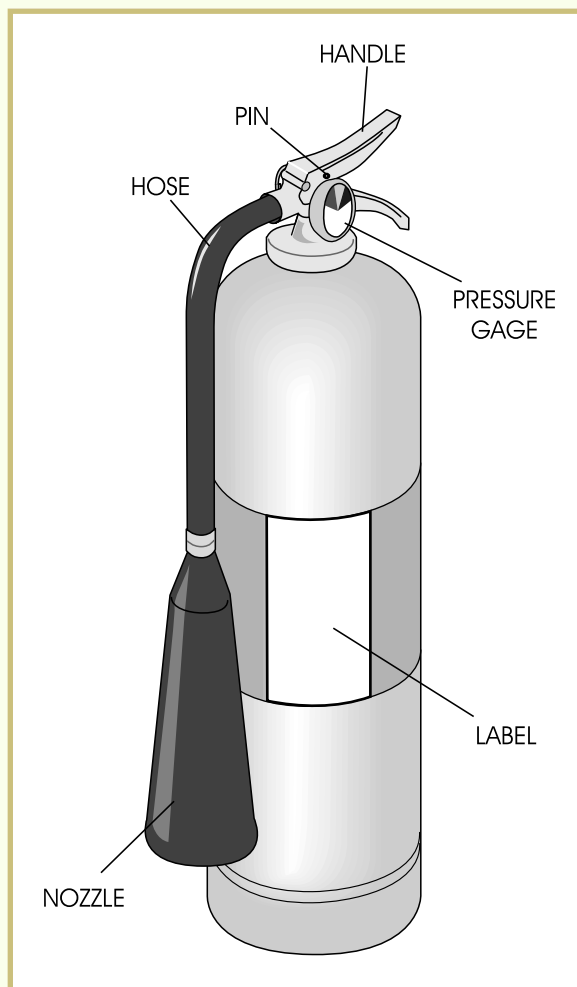

Here's a little hint. You can use the acronym *PASS* to help you remember how to operate a fire extinguisher. The letters in *PASS* stand for Pull (the safety pin), Aim, Squeeze, and Sweep.

Always direct the stream of extinguishing agent at the base of the flames. This is the fire's combustion zone. Cooling this area will extinguish the fire more quickly. Sweep the stream from side to side and work your way around the fire until it's completely extinguished. You should remember, never turn your back on a fire until you're

absolutely sure that it's completely extinguished. Heat remaining inside of partially burned materials can re-ignite the fire when you're not looking. This could trap you.

Portable fire extinguishers should be given a complete maintenance check annually. Maintenance may include recharging or pressure-testing the extinguisher. Most fire extinguishers require pressure-testing every five years. You should also inspect all fire extinguishers at least once monthly and answer the following:

- Is the extinguisher in its designated place close to possible fire hazards?
- Is the extinguisher clearly visible?
- Is access to the extinguisher free from all obstacles and obstructions?
- Is the extinguisher fully charged?

It's also a good idea (in some localities it's the law) to install *battery-operated smoke detectors* and *carbon-monoxide detectors* in all buildings. Remember, smoke detectors require some maintenance. Check the detectors and their batteries routinely to ensure that they're in proper working order. Replace batteries yearly, and replace all detectors that show any signs of malfunction or incorrect operation.

The following are some important fire evacuation procedures that you should commit to memory. Never take fire safety lightly. It's recommended that you practice these procedures in regularly scheduled exercises or fire drills.

- Get out fast. Believe the alarm when you hear it. Don't waste time trying to verify that there's a fire or trying to gather things before you leave.
- Stay low to the floor to avoid smoke and toxic gases. The clearest air is found near the floor. So crawl if necessary! Cover your mouth and nose with a damp cloth, if available, to help you breathe.
- Don't open a closed door without feeling the door's surface first. If you open a door with flames on the other side, the fire could back-draft and severely burn you. Use the back of your hand (don't burn your palms), when you test for heat. If the door feels warm on your side, the temperature is probably far above the safety level on the other side. Don't open the door; use an alternate escape route!
- Never enter a burning building. This could be a fatal mistake! Professional firefighters are equipped with special protective equipment and breathing devices that allow them to enter burning buildings. They're also trained in search and rescue techniques. Leave these tasks to the professionals.

- If your clothing catches fire, don't panic! Stop, drop to the ground, and roll around to smother the flames. If a coworker's clothing catches fire, quickly wrap the person in a blanket or rug to smother the flames. Assist the person with the *stop, drop, and roll* maneuver if a rug or blanket isn't handy.

Hazardous Chemicals

Question: Do you work with or near any hazardous chemicals? Before you answer too quickly, continue reading!

Many people are unaware that some everyday materials and products in their work areas are indeed hazardous chemicals. Materials such as paints, oils, lubricants, cleaners, degreasers, solvents, and gasoline are all potentially hazardous chemicals.

Labels on chemical containers normally list the names of the chemicals and any hazards associated with them. The labels also highlight health hazards that the chemicals present, including eye and skin contact irritation characteristics, breathing and inhalation dangers, and accidental swallowing or ingestion warnings. Many labels also include first aid procedures to administer for these hazards, the name and address of the chemical manufacturer or importer, and specific ingredients of the hazardous chemical compounds.

Some chemicals can cause a variety of serious health problems (or even death) if you're exposed to them. For example, some chemicals can produce gases and vapors that are poisonous when inhaled. Other chemicals are highly flammable or explosive when exposed to sparks or open flames. And still other chemicals can cause temporary or permanent blindness if they get splashed in the eyes. Everyone should take the potential hazards of chemicals seriously. The intent here isn't to scare you. It's to alert you to possible dangers so that you'll give chemicals the respect they deserve.

Most chemicals in the workplace aren't life-threatening but can cause minor injuries or illnesses. If you work with chemicals in your service department, always follow the safety precautions on the chemical's label and protect yourself with gloves and safety goggles.

A common problem that chemicals can cause is a skin inflammation called *contact dermatitis* or *eczema*. Contact dermatitis usually starts as redness in the area of chemical contact or exposure and may progress into blistering, scaling, and cracking of the skin surface. People who regularly expose their hands to materials such as detergents, cleaners, degreasers, oil, and gasoline are susceptible to dermatitis. Although contact dermatitis isn't a life-threatening condition, it's very uncomfortable and could lead to more serious health complications such as infections. Contact dermatitis is much easier to prevent than it is to cure, so it's important to wear industrial rubber gloves whenever you're using chemicals that could come in contact with your skin.

Exposing the skin to stronger chemicals can cause more serious injuries. For example, exposure to acids and strong bases can cause immediate, very painful burns to the skin.

The storage batteries used in many types of power equipment contain strong and dangerous acids. The sulfuric acid found in storage batteries is a particularly dangerous acid you should be aware of. It can eat through clothing or burn your skin. And more importantly, it can easily cause blindness if splashed in the eyes. Be aware that storage batteries give off dangerously explosive hydrogen gas when they're being charged. Always use extreme caution when handling, storing, replacing, charging, or adding distilled water to storage batteries.

Follow these safety guidelines when handling batteries.

- Keep batteries upright to prevent the acid from spilling or leaking.
- Always wear gloves, an apron, and safety goggles when handling batteries to protect your skin and eyes.
- Charge storage batteries in a well-ventilated location to prevent the buildup of hydrogen gas.

Electricity

We take electricity so for granted that we often lose sight of its potential to cause serious injury or death. The main hazards of electricity are electrical shocks and burns. Electric shocks and burns usually result from

- Faulty power tools or equipment
- A disorderly and untidy work environment
- Human error (the misuse of an electrical device)

Even if you don't work with electrical equipment on a routine basis, you should be aware of how shocks can occur. Generally, you must be contacting or in proximity with a conductor or a conductive surface. *Conductors* are normally metallic materials that readily pass, or *conduct*, electricity. If you're in proximity with a conductor and you contact a source of electricity, the electricity can pass through your body to the conductive material and then to ground. In such a situation, your body acts like a switch, closing the electrical circuit. The sensation that you feel is an electric shock. The shock may range from mild to severe depending on the circumstances and the source of the electricity. If you're lucky, you may experience only a brief unpleasant sensation. If you're unlucky, you could be seriously injured, or worse!

There are two types of electric-power sources: *alternating current (AC)* and *direct current (DC)*. AC current flows in *alternating cycles* and is used to run lighting circuits and appliances in most households and workplaces. DC current is continuous and steady. DC is found in storage batteries and battery-powered electric systems such as motor-cycle electrical systems.

Each type of electrical source has its own set of hazard characteristics. The AC found in the typical repair facility can be very hazardous if the path of the shock is from one hand to the other. This puts your heart in line with the alternating current flow, and can cause *fibrillation* (erratic, nonrhythmic heartbeat).

An AC shock causes the muscles to contract and relax with the alternating current cycles. This allows you to withdraw the body contact point (normally a hand) from the source of the shock when the muscles relax.

The DC found in the typical repair shop can present a more serious hazard than AC because a DC shock causes the muscles to contract and freeze. There are no alternating cycles with DC, so the muscles don't relax like they will with an AC shock. This makes it very difficult to let go of the shock contact point, extending the time that you're subjected to the danger of the shock. You can obtain severe burns, or worse, from a DC shock.

Always keep your work area clean and orderly to prevent electrical accidents. Keep floors clean and dry, because a wet or damp floor will make anyone standing on it more conductive to electricity. All portable electrical equipment (machines that have plugs and cords) should be inspected before each use to ensure that the equipment, cord, and plug are in good condition. If you feel the slightest tingle or shock while using electrical equipment, stop using it immediately! That slight tingle is an indication that there's a fault in the equipment's electrical wiring or ground circuit.

Avoid wearing conductive metals such as rings, watches, and chains when working with electricity. These metal objects significantly increase your risk of being shocked. You can increase your resistance to electric shock by wearing rubber gloves, standing on an insulating rubber mat, and using tools with insulated handles.

Exhaust Gases

When an engine is running, it creates exhaust gases that are hazardous if inhaled. The most dangerous of these gases is *carbon monoxide*. Carbon monoxide is a by-product of burning hydrocarbon fuels. It's often present in garages and around heating equipment. It's colorless, odorless, and tasteless, so you can't detect when it's present. When inhaled, carbon monoxide passes into the bloodstream and prevents red

blood cells from carrying oxygen. As a result, the body suffocates from the lack of oxygen to the brain. Even small amounts of carbon monoxide can make you very ill.

Adequate ventilation is necessary to prevent the buildup of dangerous carbon monoxide fumes. Also, *carbon monoxide detectors* should be installed in your work area. These devices are similar in appearance to *smoke detectors* and can be purchased at most hardware or discount stores. These detectors sound an alarm when a predetermined level of carbon monoxide is sensed in the air. They don't detect smoke, and can't be substituted for smoke detectors. Each type of device has its own function.

Always follow these precautions when operating an engine.

- Never operate an engine in an enclosed area. Make sure that your workshop has proper ventilation. Use exhaust pipe extensions to direct the exhaust gases to the outside. OSHA can provide detailed information about ventilation safety requirements for buildings and work areas.
- When you're operating an engine (even if your shop is well ventilated), avoid breathing the fumes.
- Never operate an engine too close to a residential building. Exhaust gases could seep in and jeopardize the well-being of those inside. If your workshop is located in an attached garage, you'll need special ventilation equipment and carbon monoxide detectors in the shop, and in the attached residence.

Safe Operation of Equipment

All motorcycles and ATVs have moving parts that can be hazardous. The careless operation of these vehicles when they're in for service can cause serious injuries and damage your workshop and your tools. To avoid accidents, follow these safety guidelines.

- Read the manufacturer's instruction manual carefully before operating any unfamiliar equipment.
- Never start a vehicle unless the transmission has been shifted into neutral.
- Turn off the ignition system before you start working, to prevent the engine from starting accidentally while you're working on it.
- Keep your hands, fingers, and sleeves clear of all hazardous moving parts.
- Keep visitors and customers (especially children) away from all risk areas and post appropriate signs to warn customers of hazards.

- Remember that the exhaust system gets very hot during operation. Keep your hands, feet, and loose clothing away from the exhaust components whenever the exhaust system is hot.

Good Housekeeping Practices

Now that we've discussed some of the hazards that may be present in a motorcycle service department, let's look at some of the things that can be done to prevent accidents. One of the most important considerations of any accident prevention and safety program is good housekeeping. Good housekeeping is more than just cleaning up! Housekeeping is a reflection on your organization and your work habits. A neat, well-organized work area provides the environment for good inventory control of parts and materials. A tidy work environment provides the basis for proper waste disposal. Your neatness can prevent parts, tools, work records, and other important items from being lost in the clutter and thrown out with the trash. Finally, a neat work area is less likely to contribute to accidents.

Here are some specific rules related to good housekeeping.

- Keep your workbenches and your work areas clean and organized at all times. You should clean your work area at least daily, preferably after each job is completed. If a job spans several days, clean up at the end of each day. Don't allow combustible debris such as paper, cardboard, string, or rags to accumulate on or under the bench. If you must use combustible materials or flammable liquids, use only the quantity needed to complete the task and immediately return the remainder to its proper storage area. Clean up any spilled materials from floors and benches immediately. Sweep the floors every day to eliminate the buildup of dirt, dust, and other litter.
- Store flammable liquids such as gasoline and solvents in a cool, dry area away from ignition sources. Avoid storing flammable liquids or other chemicals in direct sunlight, heat, or humidity. Ensure that the storage area is well ventilated to prevent the buildup of potentially explosive fumes. Check all storage areas frequently for rusted containers, corroded caps or lids, and leaking containers.
- Label all flammable liquids and other hazardous materials properly. If a substance is transferred from its original container, the second container must also be properly labeled. Use portable safety cans for transporting small quantities of flammable liquids (Figure 56). These cans are fire-resistant and have self-closing lids. Never leave cans of flammable liquids lying around when they're not in use.

FIGURE 56—Use safety cans to transport small quantities of flammable liquids.

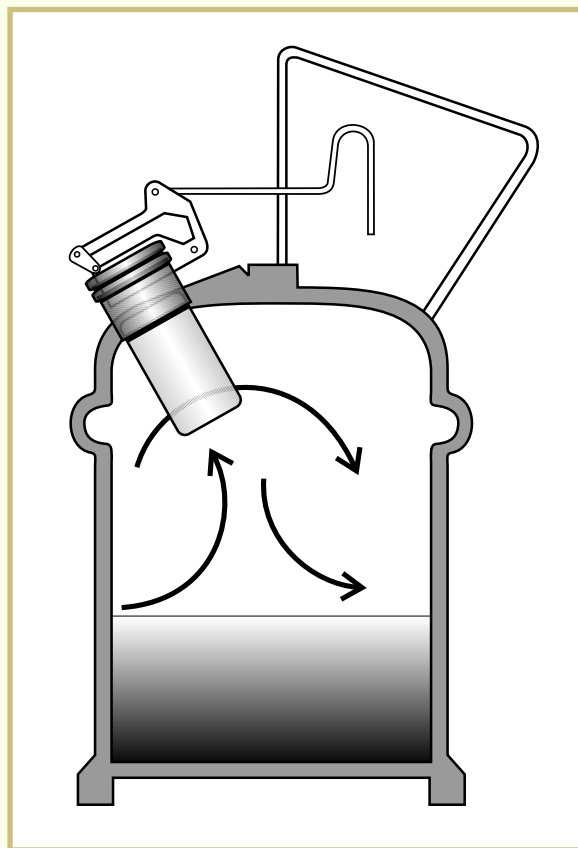

- Small amounts of flammable liquids sometimes leak or spill from machines and equipment. Place drip pans under leaking engines and vehicles to prevent the floor from becoming slippery. Drip pans should be noncombustible and should be large enough to contain any anticipated spill. If a vehicle has a persistent leak, place an absorbent, noncombustible material in the pan to soak up the liquid. Empty the drip pans regularly and dispose of the oil-soaked compounds. Oil-soaked materials are *hazardous waste* that must be disposed of properly. Don't include hazardous waste with normal trash.
- Proper garbage disposal is another important concern for motorcycle service departments. Discard dry combustibles on a regular basis and never allow them to accumulate. Place combustibles in metal containers with lids. Lids help to contain and snuff out any fire that might start inside of the containers. When you empty the smaller containers, store the accumulated waste in a large metal refuse bin with a lid. These refuse bins should be located in a remote area away from heat sources.
- It's a good housekeeping practice to separate clean combustible wastes from dirty combustible wastes. Examples of "dirty" combustibles include papers, rags, and work clothes that are soaked with oil, grease, or solvents. These contaminated materials are more flammable than clean materials. Place all contaminated

materials in separate metal containers with tight-fitting lids (Figure 57). Do you remember our earlier discussion in the fire safety section about spontaneous combustion? This is a good example of the use of a special discard container for disposing of contaminated material. Have oily rags and work clothes laundered by a professional industrial cleaning service.

FIGURE 57—Place oily rags and other combustible waste in a metal safety can.



It's important to note that used liquids contaminated with dirt, grease, oils, solvents, or degreasers are classified as hazardous wastes and must be disposed of accordingly. **Never** empty such liquids into a sink or dump them on the ground! The handling and disposal of hazardous wastes are regulated by federal, state, and local laws. **Always** follow authorized procedures when disposing of waste liquids.

Handling Heavy Objects and Materials

Material handling (moving materials from one place to another) is a concern for all occupations because this task has serious hazards associated with it. Every workplace requires some form of material handling. In a motorcycle service department, you may be required to remove or lift complete engine assemblies, packages of supplies, or pieces of equipment. Poor material-handling techniques and practices can lead to a variety of injuries including back injuries, twisted or sprained muscles and joints, hand injuries, and foot injuries. Improper material-handling procedures can also result in damaged equipment, tools, and facilities.

Because they happen so frequently, back injuries are the most costly of all injuries in terms of medical costs and lost work time. Back injuries are often the result of poor material handling and improper lifting. Most back injuries occur when workers don't know (or ignore) the proper lifting techniques. Back injuries can also result from pre-existing back problems that are worsened by lifting. Some workers know how to lift heavy items correctly but ignore proper techniques to get the job done faster. To prevent injuries, always use the following lifting techniques.

- Be sure that the weight of the load isn't beyond your capacity to lift. Usually, loads of more than 50 pounds require the assistance of a second person.
- Check that the path of travel from pick-up to drop-off is clear of obstacles.
- Get a good grip on the item to be lifted. If needed, wear gloves to improve your grip.
- Stand close to the load you're going to lift.
- Bend from the knees (squat) when lifting and setting down a load. Bending from the waist places more strain on the lower back.
- Lift with a smooth, controlled motion.
- Don't twist from the waist to place the load after lifting it. Instead, turn your entire body to set a load in place.
- Use caution when placing a load above chest height or below knee height. You put more strain on the lower back in those positions ([Figure 58](#)).

FIGURE 58—Always lift heavy loads using your legs rather than your back. Get close to the object to make lifting easier.



Here are some other suggestions to prevent back injury when lifting materials.

- Use hoists, hand trucks, carts, or dollies to lift or move heavy items. These lifting devices free you from heavy lifting and protect you from injury.
- Wear a back support belt to protect the back muscles.
- Always get help to move loads that are heavy or awkward in size or shape.
- Stretch your back and arm muscles before lifting. Stretching warms up the muscles and helps prevent muscle strains, pulls, and tears.
- Keep your back and stomach muscles in good shape. A lack of good muscle tone could contribute to a severe lifting-related injury.

Using Personal Protective Equipment (PPE)

To protect yourself from injuries in the workplace, use *personal protective equipment (PPE)* when appropriate. PPE includes items such as dust masks, safety glasses, gloves, and special footwear.

Remember that any task can be hazardous, even if the equipment is operated properly and all safety procedures are followed. Always wear personal protective equipment wherever the potential for injury exists. The type of PPE you need varies depending on the tasks you perform.

Protecting Your Eyes and Face

Protective safety glasses and goggles are available in a wide variety of styles to meet specific needs (Figure 59). *Safety glasses with side shields* provide more protection from impact and flying particles. Most safety glasses and goggles may be worn alone or over a worker's own prescription eyeglasses.

Splash goggles protect the eyes from dust, particles, and chemicals. They may contain ventilation holes to provide air circulation. *Welding glasses* have tinted or darkened lenses to protect the eyes from the bright flashes of welding arcs. A *face shield* is a cap-like device that holds a clear plastic shield over the face. The face shield protects the entire face from chemical splashes and flying particles.

Many people wear contact lenses as a replacement for glasses. Contact lens wearers must determine when it's appropriate for them to wear their contacts based on their working environment. Wearing contact lenses isn't recommended if the workplace has significant amounts of flying dirt or dust particles, or if chemical fumes are

FIGURE 59—These are some of the most common types of eye protection devices in use today.

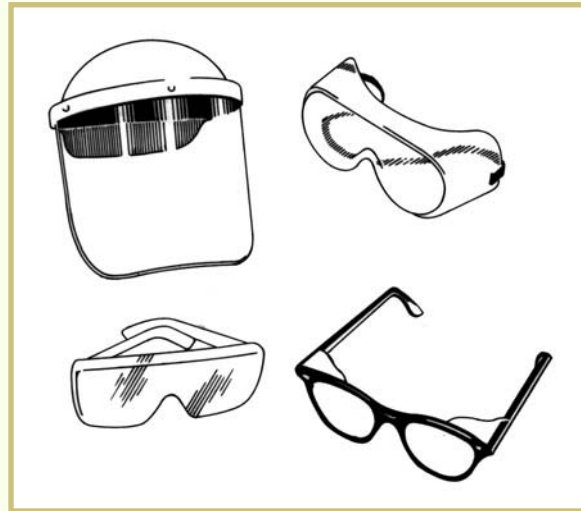

present. Remember that the only function of contact lenses is to correct your vision. They don't provide any eye protection from dust, impact, or splashes. You must still wear eye protection devices such as goggles or face shields over your eyes whenever your activity warrants such protection.

Protecting Your Lungs

Respiratory-protection devices can prevent you from inhaling harmful dusts, gases, or vapors. Any employee with an exposure to chemical fumes, dust, or any other irritants in the air should wear the appropriate respiratory protection. A typical *dust mask* is a small, fabric-like filter with straps that slip over the face to cover the nose and mouth. Dust masks are designed to shield the mouth and nose from dust particles. They don't filter out vapors, fumes, or gases.

Respirators are more substantial devices than masks. Firefighters use a form of respirator device when they're called upon to enter a burning building. Respirators are made of heavy plastic, metal, and safety glass. The firefighter's version is nonflammable and insulates the user from the high temperatures of a fire. All respirators have their own oxygen supply. Because the person using the respirator doesn't breathe any of the smoke, fumes, vapors, or toxic gasses that might be present in the air, the respirator provides the best respiratory protection available.

Protecting Your Hearing

Question: How can you tell that you're in a high-noise area without using a sound-level meter? If another worker is standing three feet away and you can't have a conversation unless you shout, the work area is too noisy!

Hearing protection should always be worn in areas with a high noise level. If you work eight hours a day in a high-noise environment without wearing hearing protection, you'll most likely experience a hearing loss over a period of years. If the noise level is extreme, you may suffer a hearing loss more quickly. You should always wear *earplugs* or a *head-set* in noisy areas or when you're using noisy tools. Remember, there's no cure for noise-induced hearing loss. The prevention of excessive noise exposure is the only way to avoid hearing damage.

Some earplugs are disposable, meant to be used once and thrown away. Others are intended to be cleaned and used repeatedly. Pre-formed or molded plugs should be individually fitted by a professional hearing specialist.

Protecting Your Feet and Legs

Foot injuries are another exposure associated with material handling. These injuries usually occur when heavy materials or tools are dropped. To prevent foot injuries, it's a good idea to wear *steel-toed safety shoes or boots*. Various types of steel-toed safety shoes are available to provide different levels of protection. You can also attach *meta-tarsal guards* (special covers that go over the instep) to your shoes to protect your feet.

Protecting Your Hands and Arms

Gloves, gauntlets, and sleeves protect the arms and hands from chemical splashes, heat, cuts, and tool-related injuries. In addition to standard leather and heavy-cotton construction, work gloves are also made from a variety of plastics and rubbers such as *nitrile* (a polymer resin/rubber compound), natural rubber, and *neoprene*. Special gloves may also be designed to resist tears, cuts, and punctures. Gloves come in a variety of lengths to cover the hand, wrist, elbow, or entire arm, depending on the requirements of the job.

Using Tools Safely

According to the *National Safety Council (NSC)*, more than 500,000 disabling, work-related finger and hand injuries occurred in a recent one-year period. The careless use of simple hand tools such as screwdrivers, wrenches, and hammers was the cause of many of these injuries. The most common hand and finger injuries are impact injuries (bruises, sprains, broken bones), cuts, and puncture wounds caused by the improper use of hand tools. Improper use means using the wrong tool for the job, holding or using the tool incorrectly, or using a damaged tool.

Motorcycle technicians use dozens of different hand tools daily. By giving your tools proper care, you'll extend their useful life, and also lessen the possibility of accidents and injuries. To keep your tools in

top working condition and to prevent injuries to yourself and your fellow workers, observe the following safety precautions.

- Always use the right tool for a job. Don't try to substitute one tool for another.
- Inspect hand tools often for defects. If you find a defective tool, repair it or replace it.
- When using a tool, comply with the manufacturer's instructions. Follow the instructions for the tool's use and maintenance.
- Never toss a tool to someone. Hand tools should be passed from one person to another by hand.
- Keep all tools clean. Protect the tools from corrosion. Wipe them clean when you're finished using them. Lubricate all tools with moving parts to prevent wear and binding. Store tools in a dry and secure location.
- Keep the cutting edges on tools sharp. Sharp tools perform better and they save time.

Power tools also have certain additional hazards associated with them. Common power tools that are used by a motorcycle technician include drills, power impact wrenches, and grinders. Electric power tools have three properties that contribute to their potential danger: electrical charge, high-speed movement, and momentum.

The most important area of concern when using power tools is the electric charge. To avoid an electric shock when using an electric power tool, you must isolate and insulate yourself from the electric current by the following guidelines.

- Make sure that all electric power tools are properly grounded.
- Inspect electric power tools often for defective wiring. Visually inspect all power cords, plugs, and receptacles. Have qualified electricians replace all defective cords and plugs.
- Always unplug tools before replacing bits, blades, or grinder wheels.
- Never operate an electric power tool in a wet or damp area.
- Wear gloves to protect yourself from shocks. If you ever feel a shock or tingle when using a power tool, stop using it immediately.
- Use only extension cords that are rated to carry the current required by the power tool. An undersized extension cord can cause damage to the tool and can be a fire hazard if it overheats because of electrical overloads.

High-speed movement is another area of concern when operating electric and air power tools. Avoid contact with any rotating tool parts because they could grab your hands, hair, or clothing. Keep all

safety guards in their proper positions when operating power tools such as grinders and drills. When drilling metal, remember that friction from the high speed produces sharp, hot shavings that could cut or burn you. Also, note that if a drill becomes jammed in a piece of material, the momentum of its moving parts may cause it to spin out of control. To avoid being injured by a tool's momentum, remember the following guidelines.

- Hold all tools firmly. Pay attention to any sounds that may indicate that a tool is about to jam.
- Use only sharp cutting bits. A dull bit will frequently jam.
- Clamp or block all workpieces tightly to a firm work surface. Don't use your hands to hold the materials in position.
- Wear the appropriate personal protective equipment when operating power tools.
- Check tools for potential mechanical failure. For example, check for broken drill bits. Also check for faulty triggers and control switches that could cause unexpected start-ups and stops. Make sure the tools have all their guards in place.

Safe Riding Practices

As a contributor to safe vehicle operating conditions, it's the motorcycle service technician's responsibility to verify that the set-up of each motorcycle and ATV is correct.

Each motorcycle manufacturer promotes riding safety by delivering a high-quality product. Quality ensures that the motorcycle or ATV has been designed with the rider's safety in mind. The motorcycle technician should always set up and service all vehicles with the same safety focus that the manufacturers used initially. Don't let a vehicle go out of the shop that you wouldn't be confident to ride yourself!

One of the most important elements of riding safety is the awareness and practice of safe riding habits. Riding safety also requires the proper riding apparel, and a properly maintained and serviced motorcycle or ATV.

The clothing that you wear while riding a motorcycle or ATV should provide visibility and protection. Leather jackets provide the best protection for your upper body. Denim provides some protection for your legs, but leather provides the best protection. Leather chaps worn over denim provide excellent protection for your legs. You should also wear sturdy footwear and gloves. A helmet and proper eye protection are the most important elements of riding apparel. Your helmet should fit securely and you should fasten the chin strap snugly.

No matter how experienced you are as a rider, an accident could happen at any time—while you're riding for pleasure, or while you're test-riding a motorcycle or ATV in the parking lot. Proper riding apparel doesn't guarantee that you'll be accident-free, but it will decrease the chances of serious or fatal injuries.

A good riding attitude is based on your understanding that a motorcycle or ATV is more vulnerable on the road or on the trail than a car or four-wheel-drive truck. Because motorcycles and ATVs are low-visibility vehicles and weigh less than nearly any other vehicle, the motorcyclist should yield in all situations. Most car and truck operators have no real appreciation of how vulnerable motorcycles can be. They don't realize that stopping distances are different, or that motorcycles are less stable on gravel surfaces. Their ignorance can get the motorcycle rider in serious trouble. Always remember that fact, and ride accordingly! Always keep the odds on your side through proper vehicle maintenance and safe riding habits. You can contact the Motorcycle Safety Foundation or your local motorcycle dealers for further information on learning how to ride safely.

Road Test 4

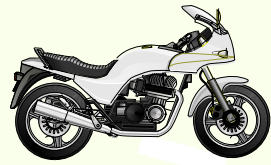

1. _____ and _____ are the main hazards of electricity.
2. The three elements of the fire triangle are _____, _____, and _____.
3. *True or False?* A Class B fire involves live electrical equipment.
4. A portable fire extinguisher should undergo a complete maintenance check every _____ months.
5. *True or False?* Dry powder compounds are usually sprayed onto a fire.
6. Name the federal agency that publishes and enforces safety standards for business and industry.

7. What are some of the key safety areas of primary concern in a motorcycle service department?

8. What's the largest and most important group dedicated to fire prevention and protection?

9. _____ is a type of fire created by a chemical reaction with combustible materials.

Check your answers with those on page 80.

Road Test Answers

1

1. Any of the following: lot attendants, set-up technicians/motorcycle assemblers, motorcycle technicians, service writers, or service managers
2. Sales, parts, and service
3. Any four of the following: technical training, factory service school training, lot attendant experience, set-up/assembly experience, motorcycle repair, customer relations, or management experience
4. obtain failure information from the customer, verify the customer's input, provide the customer with an estimate of the required services
5. set-up technician
6. Any of the following: customer transactions, warranty claims, product update and information publications, technical training, employee hiring and dismissal, equipment needs, building maintenance, service policy changes, and service files and records
7. Any of the following: technical training, higher education (college), writing experience, photographic experience, or technical illustration experience
8. Any four of the following: technical advisor, district service manager, district sales manager, district parts manager, technical writer, technical illustrator, warranty coordinator, service training instructor, customer service coordinator, quality control specialist, research and development engineer, race team support technician, advertising and marketing specialist

2

1. Any six of the following: engine, tires, wheels, handlebars, controls, fuel tank, brakes, seat, suspension, frame, and electrical system
2. street, dual-purpose, off-road
3. three-wheeler
4. 50cc to 500cc
5. sport
6. Universal Japanese Motorcycle
7. touring
8. off-road
9. 50cc to 250cc

3

1. multimeter, sometimes called a VOM (volt-ohm-meter)
2. basic hand tools, special tools, and power tools
3. torque wrench
4. Vernier caliper
5. metric
6. fuel/oil lines, brake lines
7. Allen or hex wrench
8. b
9. False

4

1. Electrical shocks, burns
2. fuel, oxygen, ignitor
3. False
4. 12
5. False
6. OSHA (Occupational Health and Safety Administration)
7. Any of the following: fire safety, chemical safety, basic electrical safety, ventilation of exhaust gases, safe operation of engines and equipment, good house-keeping practices, safe handling of heavy objects and materials, safe use of stands and lifts, proper use of personal protective equipment, and safe riding practices
8. NFPA (National Fire Protection Association)
9. Spontaneous combustion

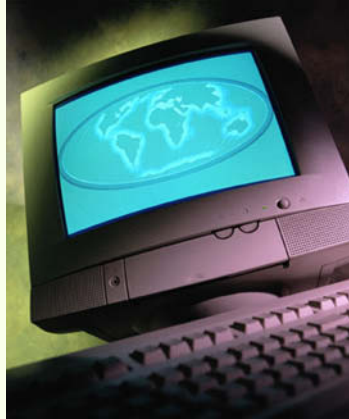

ONLINE EXAMINATION

For the online exam, you must use this

EXAMINATION NUMBER:

03300200

When you're confident that you've mastered the material in your studies, you can complete your examination online. Follow these instructions:

1. Write down the eight-digit examination number shown in the box above.
2. Click the **Back** button on your browser.
3. Click the **Take an Exam** button near the top of the screen.
4. Type in the eight-digit examination number.