

Study Unit

Two-Stroke Engine Lower-End Inspection

By

Ed Abdo

About the Author

Edward Abdo has been actively involved in the motorcycle and ATV industry for more than 25 years. He received factory training from Honda, Kawasaki, Suzuki, and Yamaha training schools. He has worked as a motorcycle technician, service manager, and Service/Parts department director.

After being a chief instructor for several years, Ed is now the Curriculum Development Manager for the Motorcycle Mechanics Institute in Phoenix, Arizona. He is also a contract instructor and administrator for American Honda's Motorcycle Service Education Department.

Preview

This study unit introduces you to the procedures used for disassembling the lower end of a two-stroke air-cooled or liquid-cooled motorcycle engine. Lower-end engine disassembly is a process in which all of the engine parts located below the cylinder are removed, inspected, and replaced when necessary.

The lower end of an engine may be disassembled to make needed repairs, or as a part of a complete engine rebuild. For a complete engine rebuild, the lower-end disassembly and inspection is done after completing the top-end disassembly and inspection as described in the previous study unit. During an engine rebuild, the engine is completely cleaned and restored to a “like new” condition, using new parts when necessary.

This study unit begins by teaching you the important preliminary steps that you must take before disassembling an engine. You’ll then go through a sample disassembly procedure to familiarize you with the steps used to disassemble almost all two-stroke engines. This disassembly procedure is illustrated with real engine examples.

Throughout the disassembly discussion, we’ll point out the special tools that are used in the process and provide you with some review information about the function of certain engine components. Following disassembly, you’ll learn how to inspect the two-stroke lower-end engine components. Finally, you’ll be led through the lower-end reassembly procedure and the process to reinstall the engine into the chassis.

When you complete this study unit, you’ll be able to

- Describe the procedures used to disassemble the lower end of an air-cooled or a liquid-cooled two-stroke engine that has a vertical crankcase design
- Identify the special tools used to disassemble the lower end of a two-stroke engine
- Visually identify the components in the lower end of a two-stroke engine
- Inspect the various parts of the crankshaft and transmission for damage or wear
- Describe the procedures required to reassemble the lower end of a two-stroke vertical-split crankcase-design engine
- List the steps required to install an engine into a chassis
- Describe what checks you should make before starting a rebuilt engine

Contents

INTRODUCTION	1
Common Lower-End Engine Failures	
Repair Procedures	
TWO-STROKE ENGINE REMOVAL	3
Cleaning the Engine and Draining the Fluids	
Removing the Chassis and Body Components	
Removing the Engine from the Chassis	
TWO-STROKE ENGINE LOWER-END DISASSEMBLY	9
Removing the Magneto Rotor and Stator	
Removing the Clutch and External Components	
Opening the Crankcase and Removing Components	
TWO-STROKE ENGINE LOWER-END INSPECTION	17
Inspecting Engine Crankcases	
Inspecting and Replacing Engine Seals	
Inspecting and Replacing Engine Bearings	
Inspecting the Clutch	
Inspecting and Measuring the Multipiece Crankshaft	
Inspecting the Transmission	
Transmission Power Flow and Symptoms	
TWO-STROKE ENGINE REASSEMBLY PROCEDURES	31
Installing Crankcase Components and Closing the Crankcase	
Installing the Clutch and External Components	
Installing the Magneto Rotor and Stator	
Bench Testing	
TWO-STROKE ENGINE INSTALLATION	39
Installing the Engine into the Chassis	
Installing Chassis and Body Components	
Starting the Engine	
Breaking in the Engine	
ROAD TEST ANSWERS	45
EXAMINATION	47

Two-Stroke Engine Lower-End Inspection

INTRODUCTION

The lower end of a two-stroke engine is a section of the engine that often needs repair. It's important that you understand how to disassemble the engine right down to the crankshaft. It's also important that you know how to inspect the engine, do any necessary repair work, and reassemble the engine correctly. In this study unit, you'll find a step-by-step description of what to do, when to do it, and how to do it.

We've used a Suzuki DS 80 air-cooled motorcycle and a Suzuki RM 125 liquid-cooled motorcycle as the models in most of our illustrations in this study unit. Other two-stroke motorcycles and ATVs may vary somewhat, but the basic principles of disassembly, repair, and reassembly remain the same.

Repair of the lower-end assembly always requires that the engine be removed from the chassis. Therefore, you should first be sure the malfunctioning component is located in the lower engine assembly. After all, you'd never want to remove an engine from its chassis and disassemble it completely, just to find out that the failed component didn't require any major disassembly.

Common Lower-End Engine Failures

The following is a brief discussion of some areas in the lower-end assembly where malfunctions commonly occur.

Leaking Engine Seals

A leaking oil seal sometimes requires that the engine's lower end be disassembled. Always confirm that the replacement of the faulty oil seals requires complete disassembly before tearing down the lower end. You can do this by checking the appropriate service manual before you begin the work.

Worn Crankshaft Bearings

Crankshaft bearings are used to mount the crankshaft assembly into the crankcase. Bearing failure is indicated by a rough, growling sound. Use a mechanic's stethoscope to help pinpoint the location of the bad bearing. Bad bearings may also allow excessive up-and-down movement of the crankshaft, or even prevent the engine from

rotating. Very bad bearings can sometimes seize, meaning that they rotate with great difficulty, or not at all.

Worn Connecting-Rod Bearings

Connecting-rod bearings are used to allow the connecting rod to rotate as the crankshaft assembly turns. The following are some symptoms of bad connecting-rod bearings.

- The engine knocks.
- The engine starts, but won't run freely.
- The engine can't be rotated manually (it's locked up).

Any of these symptoms will necessitate disassembly and repair of the lower end of the engine.

Transmission Problems

Another reason to disassemble the lower end of an engine may be because of transmission problems. Both the engine and transmission of most two-stroke motorcycle and ATV engines are contained in a single casting (engine case). The procedure for separating the case is similar for most engines.

This study unit includes the disassembly, inspection, and assembly of the transmission. Any suspected transmission malfunction should be investigated while you have the engine case opened. Because the clutch commonly wears out in a two-stroke engine, we've included clutch repair procedures, even though the clutch doesn't require the disassembly of the lower end or removal of the engine from the chassis.

Repair Procedures

Being alert to other problems when you're performing repairs on an engine will help you to become a fully competent motorcycle and ATV technician. In this study unit, we'll list the necessary procedures to disassemble, inspect, repair, and replace worn parts in single-cylinder two-stroke air-cooled and liquid-cooled engines. Most of these procedures also apply to other motorcycle and ATV two-stroke engines that you'll work on as a technician.

As we've mentioned before, be sure that the motorcycle or ATV is clean before you begin any disassembly work. Use a water-soluble degreaser, which you can buy at a motorcycle dealership. Use the degreaser according to the manufacturer's directions. Remember that dirt or foreign particles can ruin your repairs if allowed to enter the working parts of the engine.

The disassembly of the lower end of a two-stroke engine requires that the top end be removed first. Therefore, we'll assume that the top end of the engine has been removed, using the procedures in the previous study unit.

The procedures in this study unit are general in nature and not intended to be used for actual disassembly and repair. Their purpose is to familiarize you with the types of activities you'll encounter. Always refer to the appropriate motorcycle or ATV service guide for maintenance information. The service guide contains all the information to do the job correctly, including: detailed instructions for the specific make and model of motorcycle or ATV, special tools, and service tips. Above all, the service guide contains the appropriate safety information.

Before we can disassemble the lower end of the engine, the engine must be removed from the chassis. So, let's get started by learning how to remove the engine, and then we'll learn how to inspect, repair, and reinstall the engine.

TWO-STROKE ENGINE REMOVAL

As we discussed in the previous study unit, the two-stroke engine top-end assembly can be removed and inspected without removing it from the chassis. However, to disassemble the two-stroke engine lower-end components, such as the crankshaft or transmission, you must first remove the engine from the chassis. The procedure to remove a two-stroke motorcycle or ATV engine from its chassis is quite simple when a systematic approach is used.

The procedure to remove most motorcycle engines from the chassis is consistent in that certain parts are removed in a pattern. This pattern generally applies to all makes and models of motorcycles and ATVs. The parts to be removed usually include, but aren't limited to, the following:

- Battery (when applicable). This is a safety measure to prevent a possible fire due to an accidental spark igniting spilled gasoline.
- Seat and frame covers
- Fuel tank (to free control cables, or to access a top engine-mounting bolt)
- Fairings and bodywork (cosmetic covers)
- Chain
- Control cables

- Ignition and other electrical wiring that may be attached to the engine
- Engine mounting bolts

Certain models may require that some smaller parts be dismantled to facilitate removal of the engine.

It's not possible to list each part for each brand and model. Refer to your service manual for the exact information concerning engine removal. You'll need to remove only those components that interfere with removing the engine or installing it back into the chassis.

We'll follow the procedures for removing the engine from our example motorcycles—the liquid-cooled Suzuki RM 125 (Figure 1) (and the air-cooled Suzuki DS 80 (Figure 2). Although our examples are both single-cylinder motorcycles, the basic procedure for disassembling a two-stroke ATV is the same. We'll illustrate the specific differences between removing the engines from each of these machines, but as you'll see, there are many similarities as we remove the engine from the chassis. We'll follow the procedures in steps to help you to better understand the correct way to remove an engine from an air-cooled two-stroke motorcycle as well as the special procedures to remove a liquid-cooled engine.

FIGURE 1—The Suzuki RM 125 Motorcycle is being used for our liquid-cooled two stroke engine

example. (Courtesy of American Suzuki Motor Corporation)



FIGURE 2—The Suzuki DS 80 motorcycle is being used for our air-cooled two-stroke engine

example. (Courtesy of American Suzuki Motor Corporation)



Cleaning the Engine and Draining the Fluids

Before attempting to do any work on a motorcycle or ATV, it's very important to thoroughly clean the engine and the surrounding components with a suitable cleaner. There are many types of cleaning agents available at your local motorcycle or ATV dealership. You'll find that disassembly is much easier when you're working with a clean piece of equipment.

Note: The illustrations used in the following example procedure are courtesy of the American Suzuki Motor Corporation.

- 1 Drain the transmission oil to prevent any chance of spilling oil when you remove the engine from the chassis. Place a suitable container under the oil drain plug. Use a wrench to remove the oil drain plug and allow the oil to flow into the container.

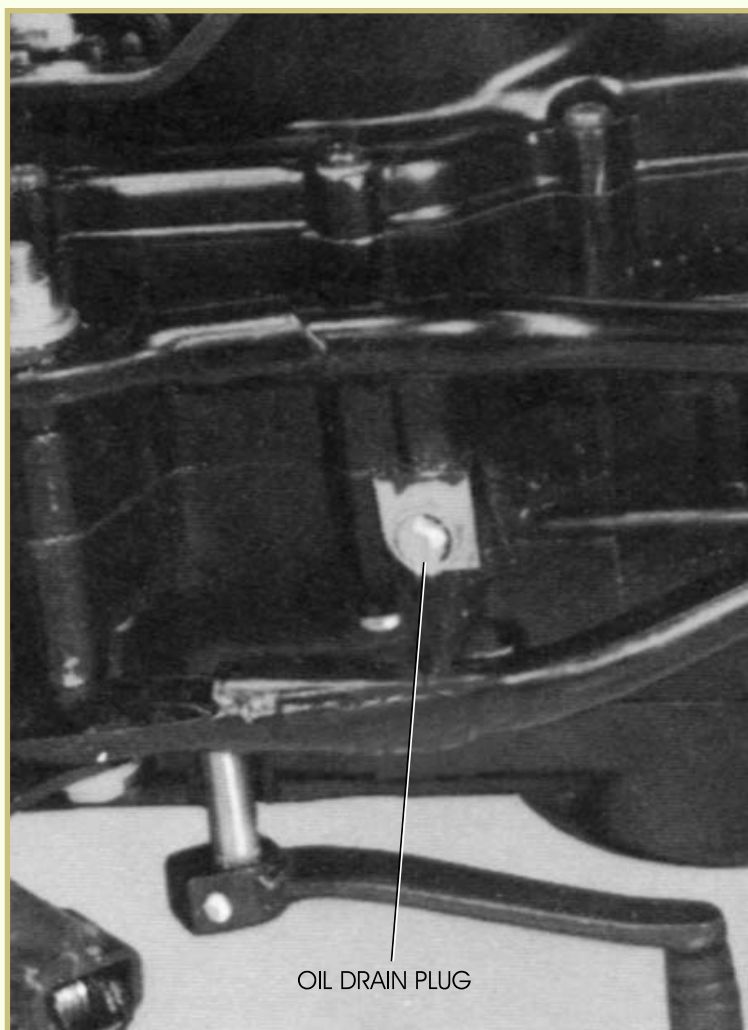

- 2 On liquid-cooled engines, place a suitable container under the coolant drain plug. Use a wrench to remove the coolant drain plug and allow the coolant to flow into the container.

Note: If you remove the radiator cap before draining the coolant, you'll find that the coolant will drain faster.

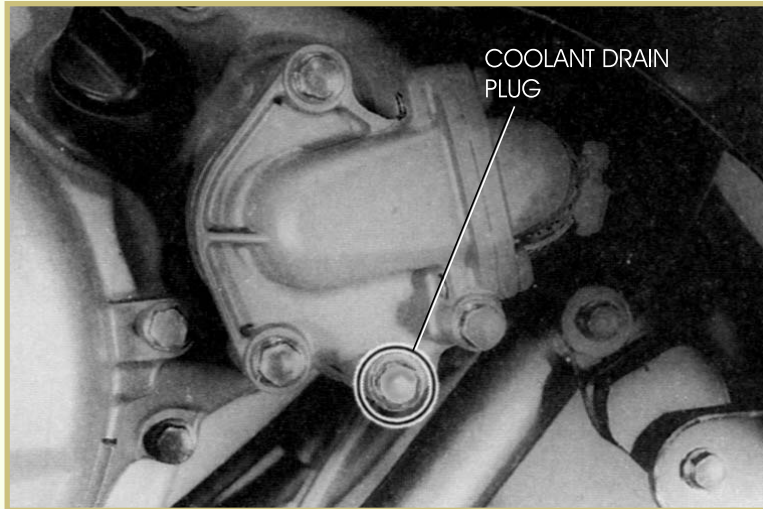

Removing the Chassis and Body Components

Depending on the particular motorcycle or ATV, certain chassis and body components need to be removed before the engine can be removed from the chassis.

Note: The illustrations used in the following example procedure are courtesy of the American Suzuki Motor Corporation.

- 1 Remove the seat and side covers including the radiator covers on liquid-cooled engines. On some ATVs, it may be necessary to remove the fenders.
- 2 Remove the battery (applicable models).
- 3 Remove the fuel lines, tank, and tank brackets.

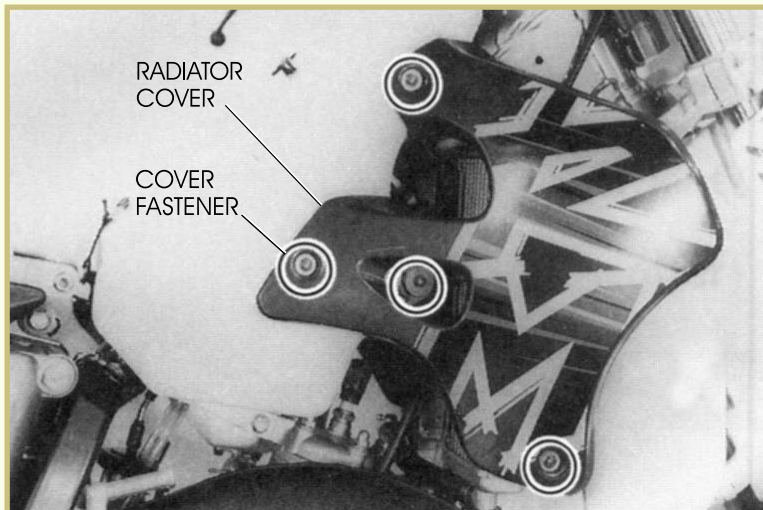

- 4 Remove the coolant lines and radiator on liquid-cooled models.
- 5 Remove the spark plug from the cylinder head.
- 6 Disconnect the hoses and control cables from the carburetor. Remove the mounting hardware securing the carburetor to the engine and remove the carburetor.
- 7 Remove the engine sprocket cover.

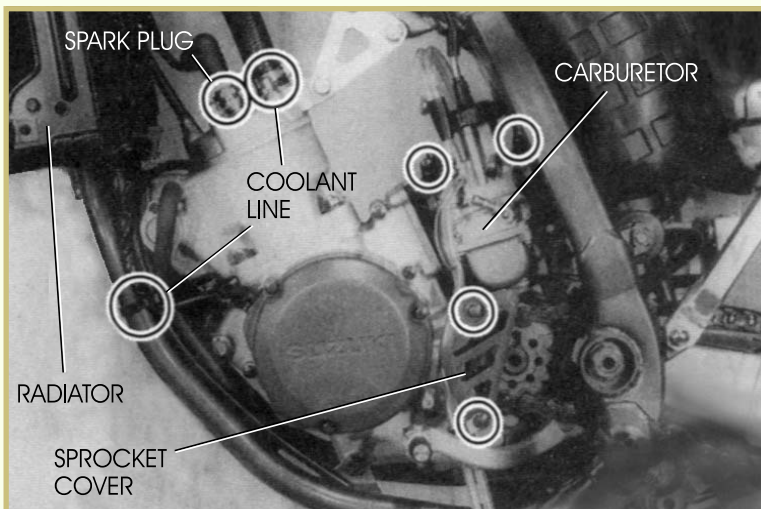

- 8 Remove the mounting hardware securing the exhaust system to the engine and chassis. Remove the exhaust system.

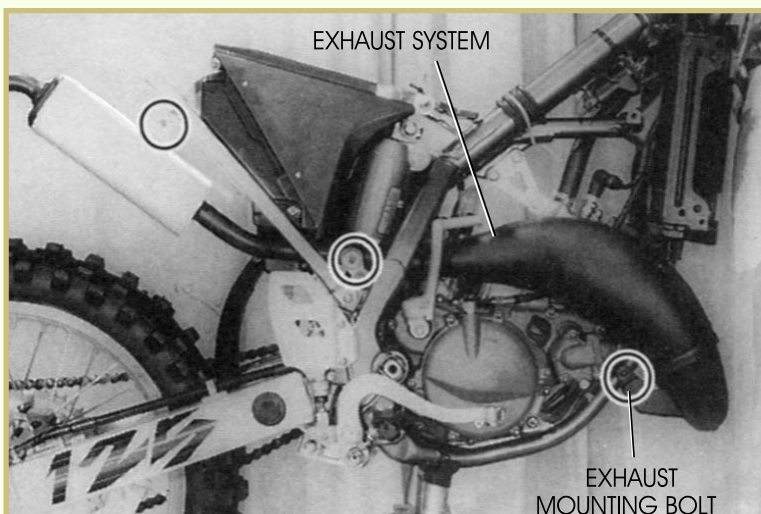

Note: A trick for easier removal of the engine sprocket bolt or nut, is to put the engine in gear and apply the rear brake firmly before removing the drive chain.

- 9 Find the master link on the drive chain. Open the master link and remove the drive chain from the engine and wheel sprockets.
- 10 Remove the engine sprocket.
- 11 Remove all control cables and electrical wiring, as necessary, to free the engine.

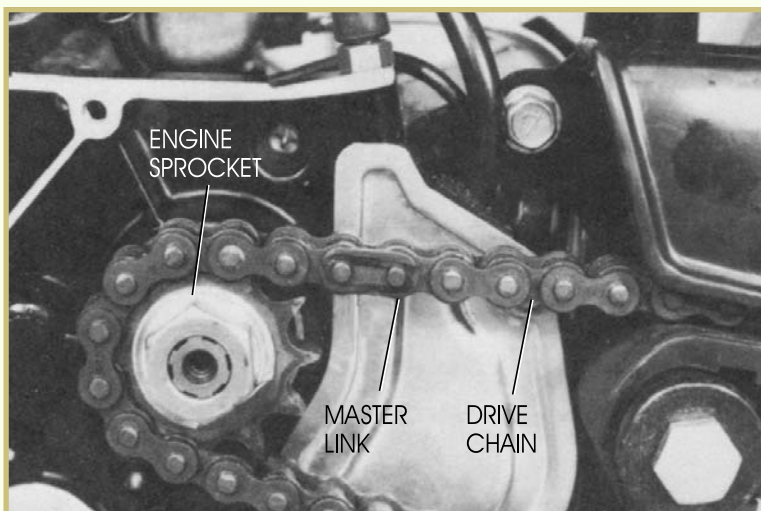

Removing the Engine from the Chassis

With the fluids drained and the chassis and body components removed, the engine can now be removed from the chassis.

Note: The illustrations used in the following example procedure are courtesy of the American Suzuki Motor Corporation.

- 1 The number and location of engine mounting bolts is different on various models of motorcycles and ATVs. Some engines have a swing-arm pivot bolt that serves as both a mounting bolt and a swing-arm bolt. Carefully remove the engine mounting bolts.
- 2 Depending on the particular motorcycle or ATV, the engine will probably be removed from either the left or right side of the chassis. Refer to the service manual to determine the proper removal procedure.

Note: A motorcycle or ATV engine can weigh over 100 pounds. It's advisable to obtain assistance when removing the engine from the chassis.

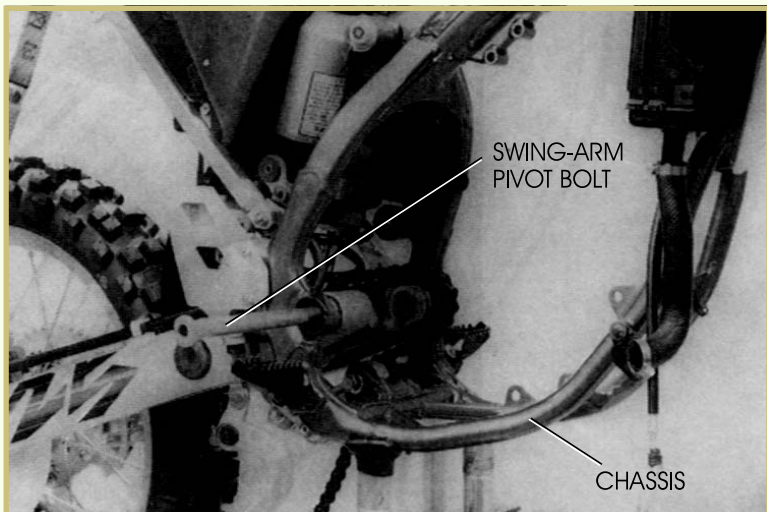
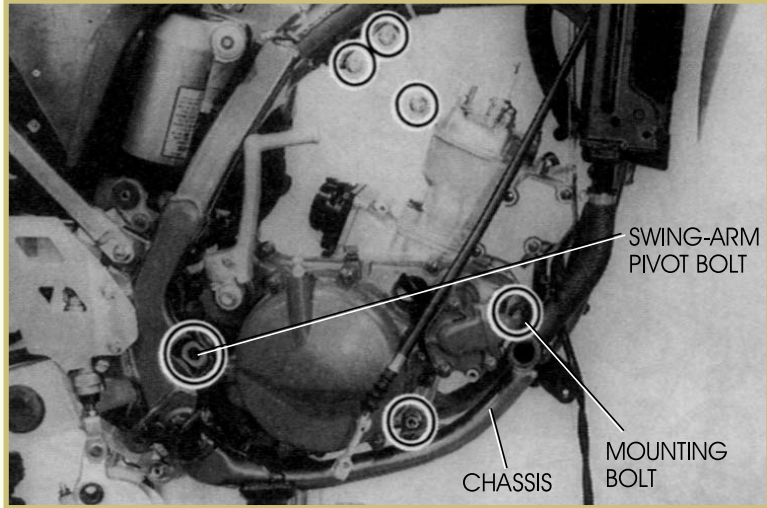

Road Test 1

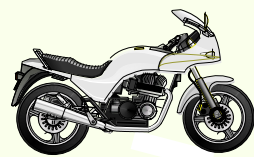

At the end of each section of *Two-Stroke Engine Lower-End Inspection*, you'll be asked to check your understanding of what you've just read by completing a "Road Test." Writing the answers to these questions will help you review what you've learned so far. Please complete *Road Test 1* now.

1. Why should you drain all of the fluids before you take an engine out of the chassis?

2. *True or False?* Some two-stroke motorcycles use a swing-arm pivot bolt to help hold the engine in the chassis.
3. Before attempting to do any work on a motorcycle or ATV, you should always thoroughly _____ the machine.
4. Name at least three types of engine problems that would require disassembly of the lower end of the engine.

5. On a liquid-cooled engine, what should you remove (besides the drain bolt) to help allow the coolant to drain from the engine?

Check your answers with those on page 45.

TWO-STROKE ENGINE LOWER-END DISASSEMBLY

With the engine removed from the chassis, we're ready to disassemble the lower end of the engine. We're assuming that the top end of the engine has already been removed, as discussed in the previous study unit.

The Suzuki RM 125 and Suzuki DS 80 that we're using for illustrative purposes both use a vertically-split crankcase assembly. The following is an overview of the steps necessary to disassemble the lower end of the engine for inspection and repair.

Removing the Magneto Rotor and Stator

Before you can begin a total disassembly of the engine, the *magneto rotor*—also known as a *flywheel*—must be removed. Magneto rotors are easily damaged and must be handled with care. Most rotors require the use of a special tool called a rotor puller (or flywheel puller) to remove the rotor without damaging it.

Note: The illustrations used in the following example procedure are courtesy of the American Suzuki Motor Corporation.

- 1 Remove the bolts securing the magneto rotor cover and remove the cover.



- 2 Using a special tool called a rotor puller to keep the rotor from turning, remove the rotor fastener nut.

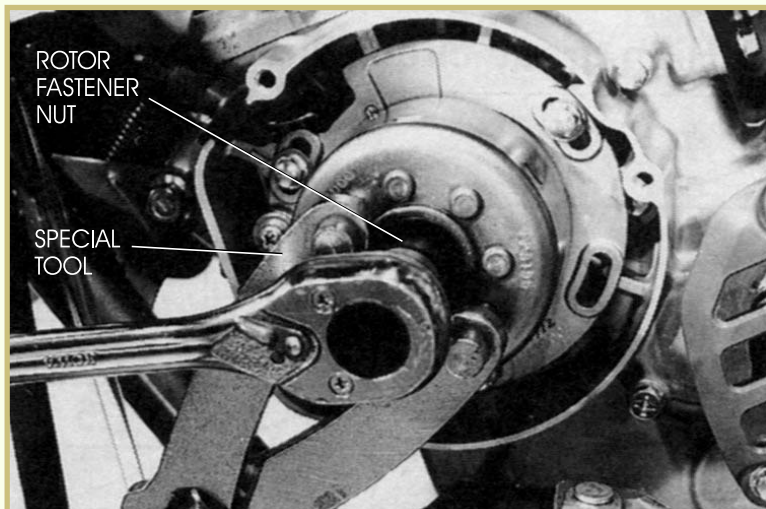

- 3 Use the rotor puller special tool to remove the rotor.

Note: Don't attempt to improvise. Use the appropriate tool to avoid damaging the magneto rotor. Above all, don't try to pry the rotor with a screwdriver and never hit the rotor with a hammer.

- 4 Remove the Woodruff key from the crankshaft so that it isn't misplaced.
- 5 Place all of the rotor assembly parts together and set them aside in a safe place until you are ready to reinstall the rotor.
- 6 Remove the stator securing screws and remove the magneto stator.

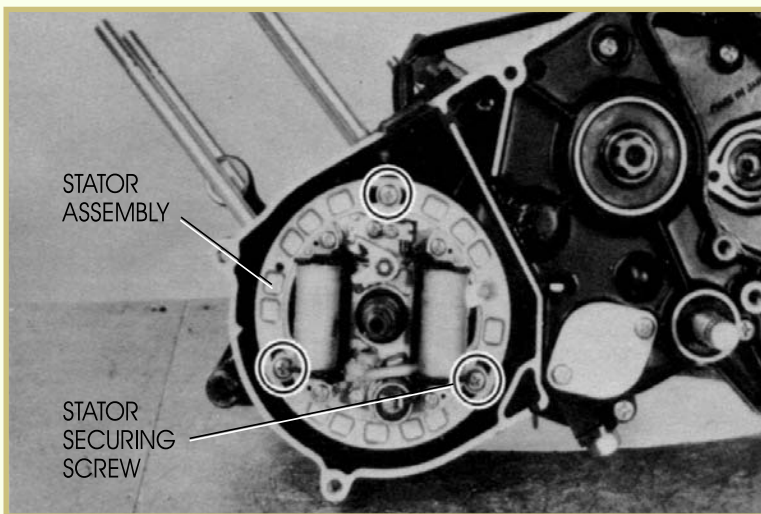
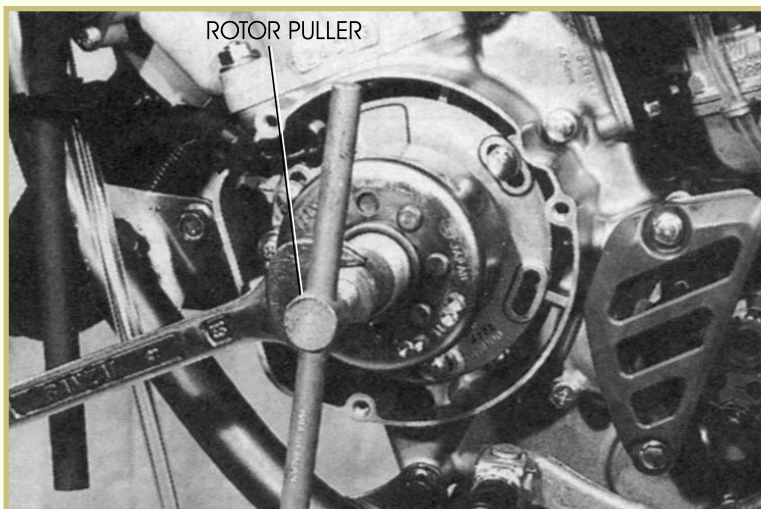

Removing the Clutch and External Components

The clutch and related components are located on the opposite side of the engine. You'll begin by removing the clutch cover to access and remove the clutch components. When you've completed the removal of the clutch and external components, you'll be ready to open the crankcase.

Note: The illustrations used in the following example procedure are courtesy of the American Suzuki Motor Corporation.

- 1 Remove the clutch cover securing screws and remove the clutch cover.

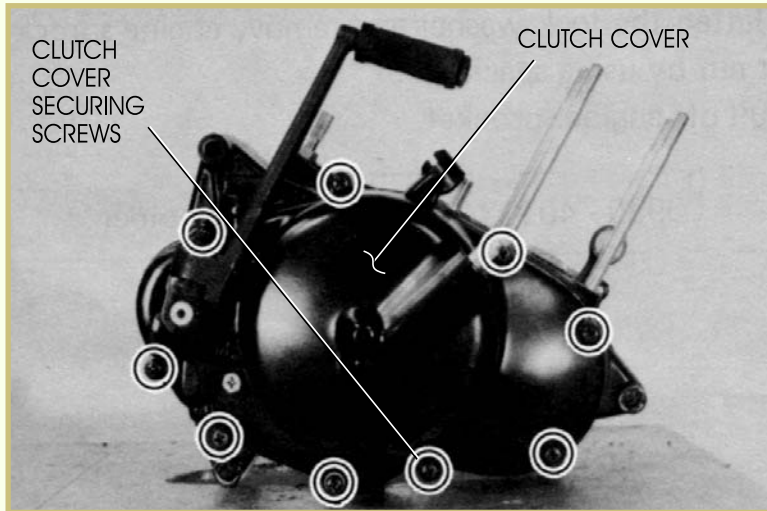

- 2 Once the clutch cover is removed, the water pump will be visible.

Some water pumps are integrated into the clutch cover while others are a completely separate component. Do *not* remove the water pump.

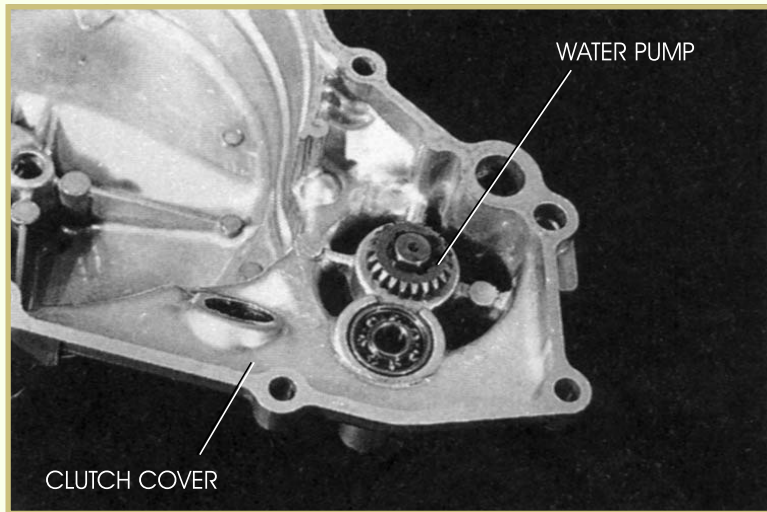

- 3 Remove the clutch spring securing screws and remove the clutch springs.

- 4 Lift the pressure plate out of the clutch assembly.

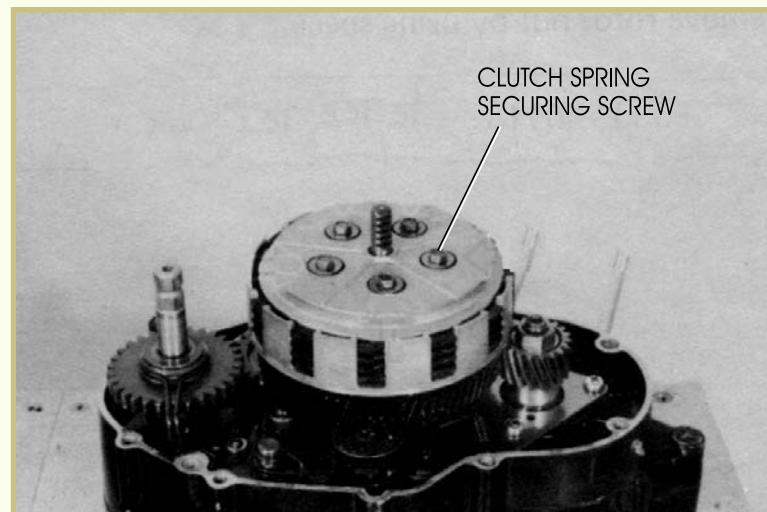

- 5 Attach a holding tool to the clutch inner hub.
- 6 Remove the clutch nut.

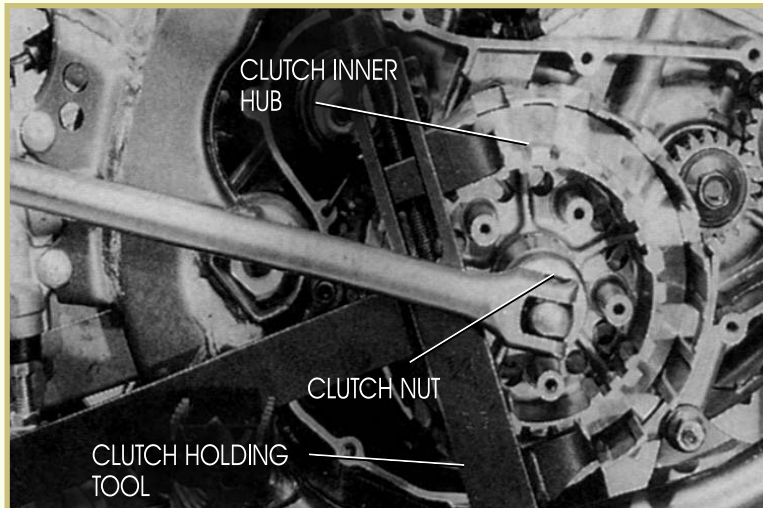

- 7 Remove the clutch plates and friction disks.
- 8 Remove the clutch inner and outer hub.

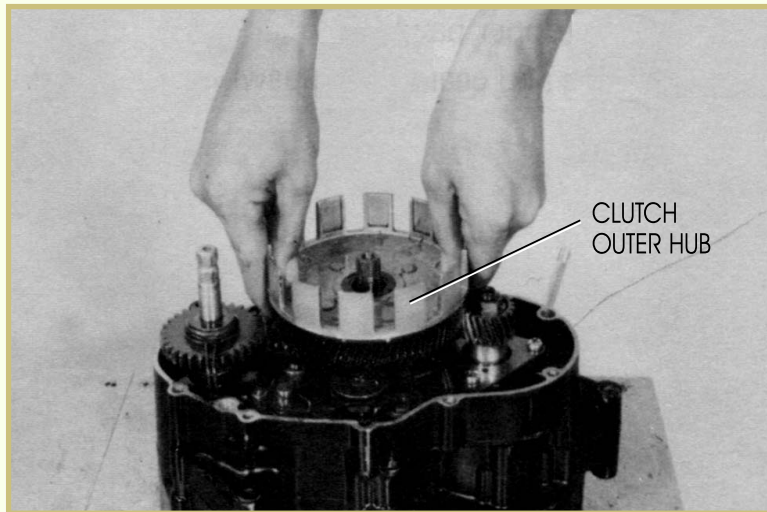

- 9 Remove the retaining ring and remove the idler gear from the shaft.

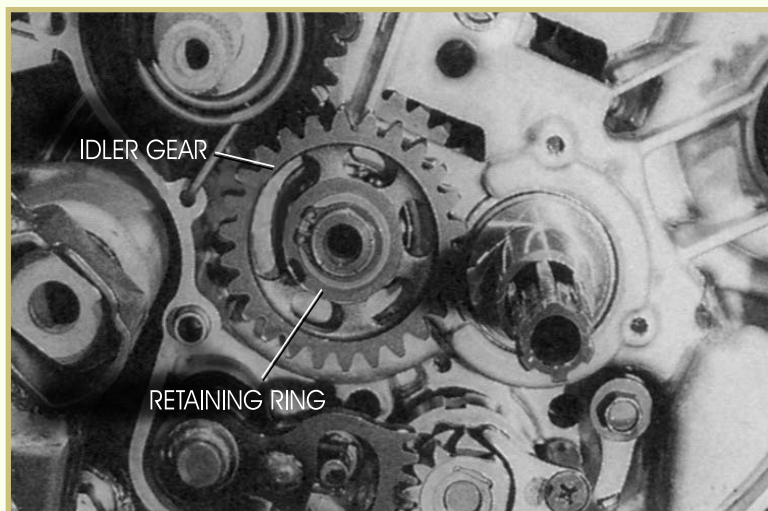

- 10 Remove the kickstarter drive gear assembly.

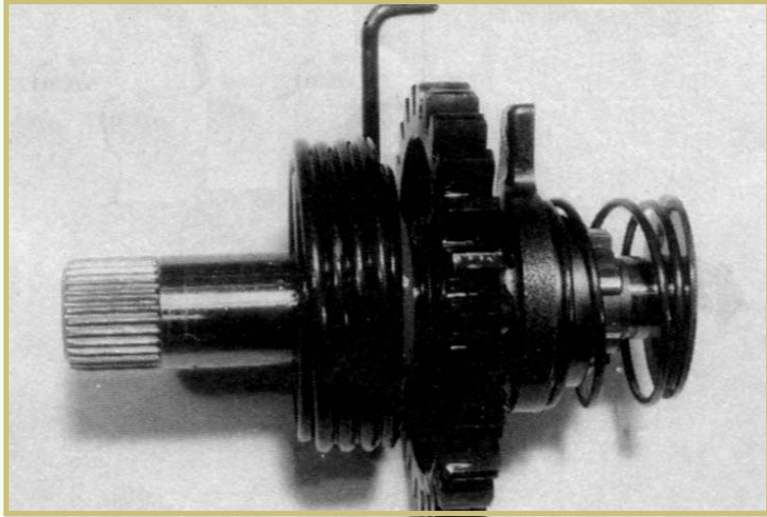

- 11 Remove the crankshaft drive gear holding nut.

- 12 Remove the primary drive gear and the drive gear key (if applicable).

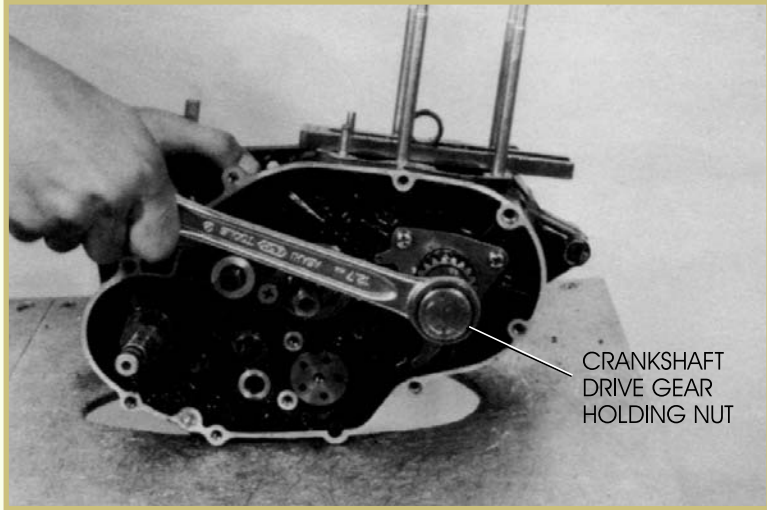

- 13 Remove the gearshift shaft and its associated parts from the engine case.

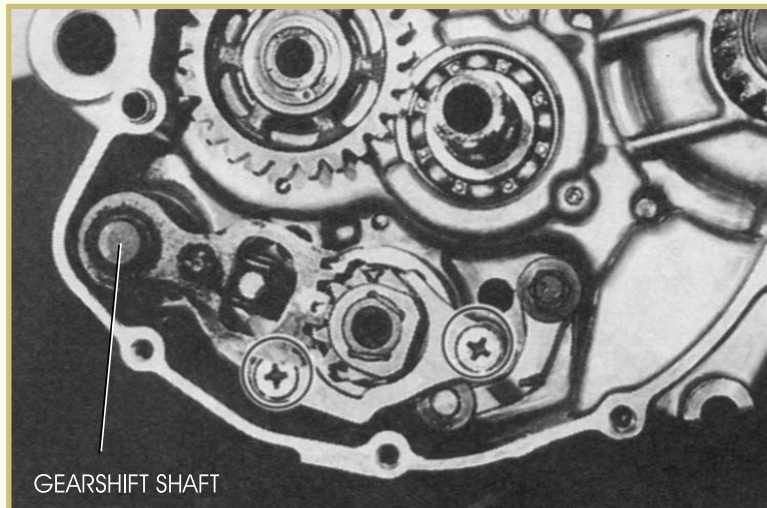

Opening the Crankcase and Removing Components

With the vertical crankcase design, the top end of the engine must be removed before the crankcase halves can be separated. This is because the cylinder is attached to both halves of the crankcase. The following procedure describes how to open the crankcase and remove the components.

Note: The illustrations used in the following example procedure are courtesy of the American Suzuki Motor Corporation.

- 1 Remove the crankcase securing bolts.

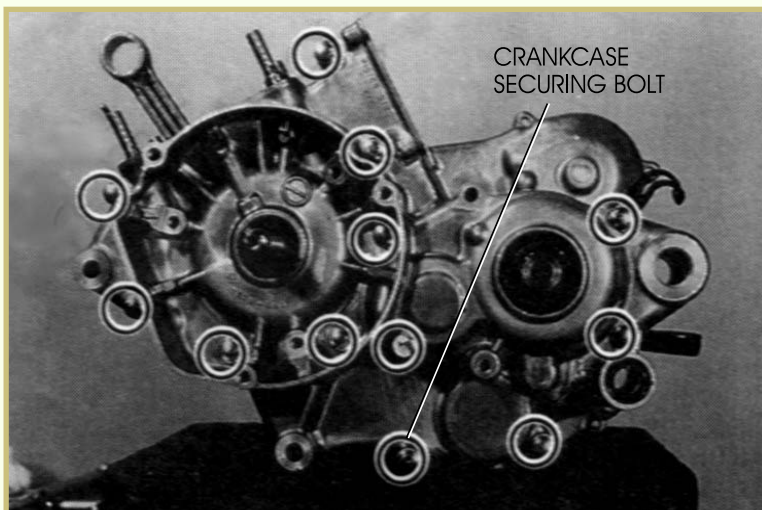

- 2 Using a special pulling tool similar to the one shown, separate the crankcase halves. As the crankcase halves are separated, the crankshaft and transmission will remain in one side of the crankcase assembly.

Note: On most models, washers are used to align the crankshaft and gears. Use care as you pull the crankcase halves apart. Be sure to note the correct position for each spacer. The engine must be reassembled with these spacers in their original position to ensure correct alignment of the crankshaft and gears.

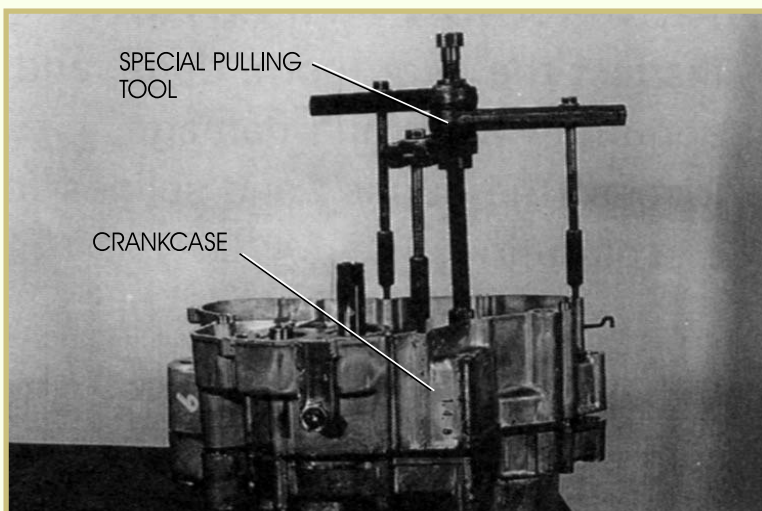

- 3 Remove the transmission from the crankcase by removing the gearshift fork shafts, transmission gears, forks, and the gearshift drum. Be careful not to misplace any transmission parts.

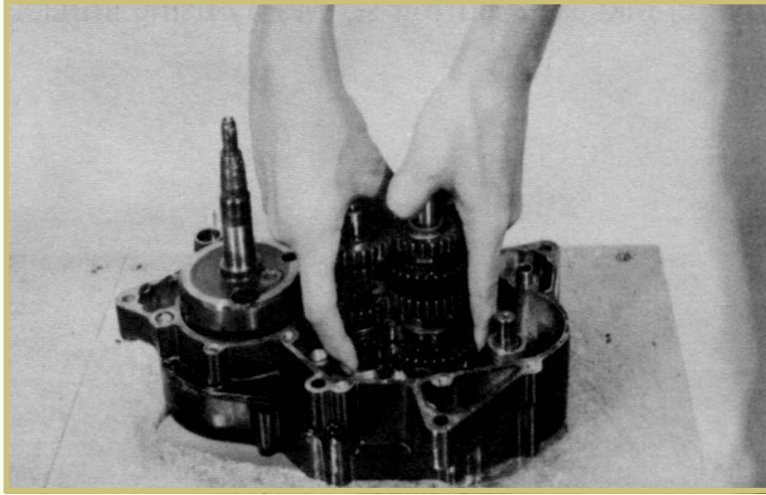

- 4 Using the special pulling tool that was used to separate the crankcase halves, remove the crankshaft from the crankcase.

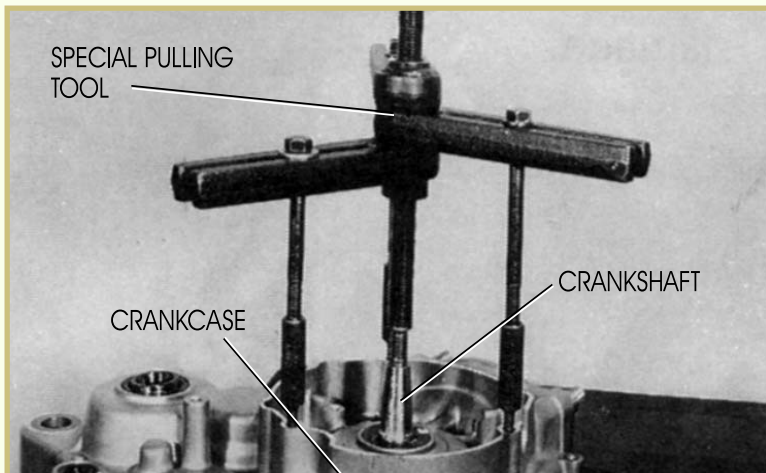

Road Test 2

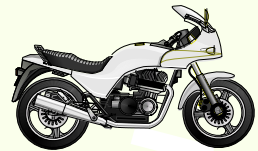

1. What major top-end components must be removed before you can separate the crankcase on a vertical-crankcase two-stroke engine design?

2. Which ignition system component is found behind the magneto rotor?

3. *True or False?* A screwdriver is considered to be an acceptable tool to help remove a magneto rotor.
4. *True or False?* The last component to be removed from the engine crankcase is the transmission main shaft.

Check your answers with those on page 45.

TWO-STROKE ENGINE LOWER-END INSPECTION

Now that the lower end of the engine has been disassembled, it's time to inspect each component for damage and wear. Although you may be trying to locate a particular problem, you should carefully inspect all of the engine components while the engine is disassembled. Because a complete engine disassembly is a lengthy procedure that isn't done frequently, it's important to make sure that the job is done right and that there are no existing problems or soon-to-be problems as well.

We'll learn how to inspect the lower end of a two-stroke engine by beginning with the engine crankcase.

Inspecting the Engine Crankcase

The engine crankcase halves should be closely inspected for cracks, loose fitting bearings, and worn-out fastener anchoring points. If there are stripped bolt holes, they may be repaired by using a special thread repair kit that reconditions the hole. The Heli-Coil and the Time-Sert are two popular methods of thread repair and should be available from your local motorcycle dealership or an automotive tool supplier.

Inspecting and Replacing Engine Seals

Engine seals are located on all two-stroke engine shafts that rotate and are exposed to the outside atmosphere (Figure 3). You must inspect all seals to verify that they are in good condition. Inspect the oil-seal lips for wear and damage. Damage to the lip of the oil seal may result in leakage of the air-and-fuel mixture or oil. Inspect the seals very carefully. If a seal isn't in perfect condition, replace it. The rubber of the seal must be "live." That is, the lip of the seal must be soft and springy. Most seals have a small coil spring which fits on the outer side of the seal lip. Be sure this spring is in place.

FIGURE 3—A transmission seal is pictured here.

(Courtesy of American Suzuki Motor Corporation)

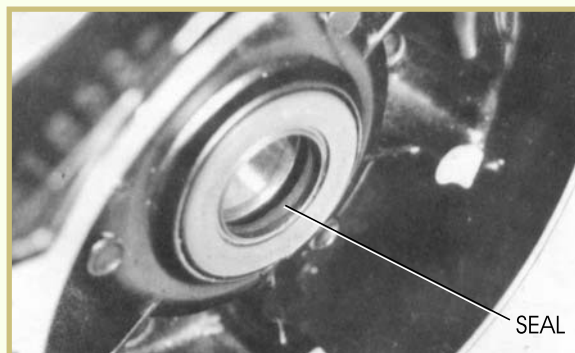

Seals are removed using a special tool, as seen in [Figure 4](#). If you remove a seal, replace it with a new one. Never try to reinstall an old seal.

FIGURE 4—A special tool is used to remove seals.

(Courtesy of American Suzuki Motor Corporation)

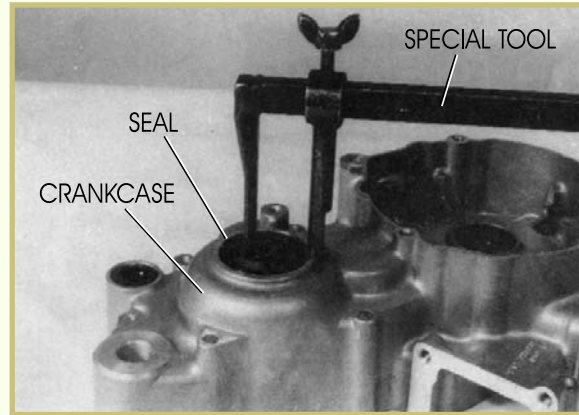

A new seal must be installed evenly in the hole. Use a mallet or a special seal installation tool to tap a new seal into place, as shown in [Figure 5](#). If a seal doesn't fit correctly, the oil or air-and-fuel mixture can leak. Be sure to install the seal into the case properly. The manufacturer's identification number is usually on the side away from the bearing or shaft to be sealed.

FIGURE 5—Seals are installed using a special tool like the one shown here.

(Courtesy of American Suzuki Motor Corporation)

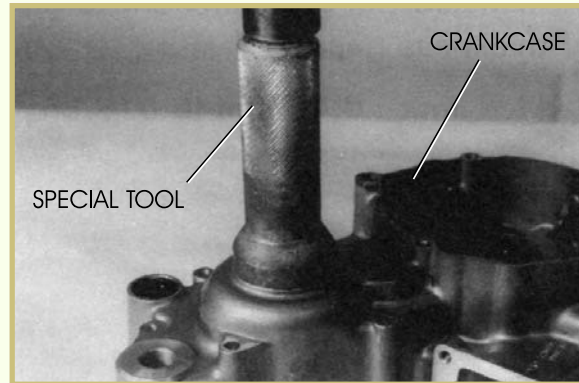

Some engine seals are located on the inside of the crankcase cavity, and can be replaced only when the crankcase halves are separated. Therefore, it's always a good idea to install new seals whenever you have the crankcase opened. You should always install new seals if you have any doubt about the condition of the old seals. You should also install new seals whenever you replace bearings.

Inspecting and Replacing Engine Bearings

The most common bearing that you'll find in a motorcycle or ATV two-stroke engine is the ball bearing. Remember that bearings usually make a low growling sound when failing. You can inspect the play of the bearing inner race by hand while it's still mounted in the crankcase (Figure 6). You can also rotate the inner race by hand and inspect it for any abnormal noise or lack of smooth operation.

FIGURE 6—You can check for play, and feel the operation of the bearing to verify that it's in good condition.

(Courtesy of American Suzuki Motor Corporation)

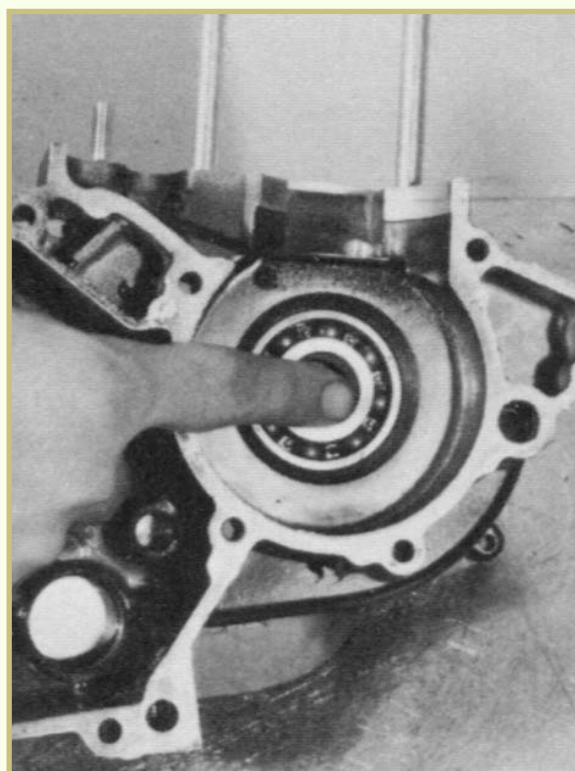

Visually inspect the races, balls, or rollers of the bearing. If they show signs of wear, chips, cracks, or damage to the hard bearing surface, they must be replaced.

If a bearing isn't in perfect condition, it should be replaced. To replace any two-stroke engine bearing, you must first remove the old bearing (Figure 7). Removal of crankcase ball bearings sometimes requires heating the case. The best way to heat the case is to place the case on a hot plate. This expands the aluminum and allows the bearings to be pressed or tapped out. Heating the case also ruins the seals, which is another reason why the seals should be replaced along with the bearings.

Before installing new bearings, put the bearings in a freezer to shrink them. Heat the crankcase to expand the case metal before installing the bearings.

FIGURE 7—This illustration shows a bearing puller being used to remove a bearing from the crankcase.

(Courtesy of American Suzuki Motor Corporation)

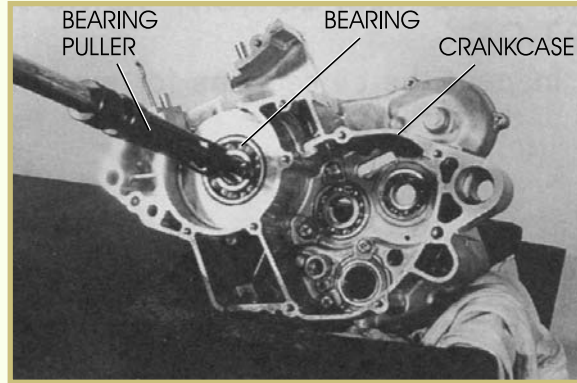

Ball bearings are held in the case by a tight fit which is called an *interference fit*. Placing cool bearings into a warm case makes for easy installation while ensuring a tight fit when both the bearing and case have returned to a normal temperature. This is because the cooled bearings expand as they warm up, and the warmed case shrinks as it cools down. A special tool, like the one shown in [Figure 8](#), should be used to install the bearing evenly. Be sure to strike the bearing only on its outer cage or you'll damage the bearing inner cage.

FIGURE 8—The installation of bearings is similar to the installation of seals, using a special tool.

(Courtesy of American Suzuki Motor Corporation)

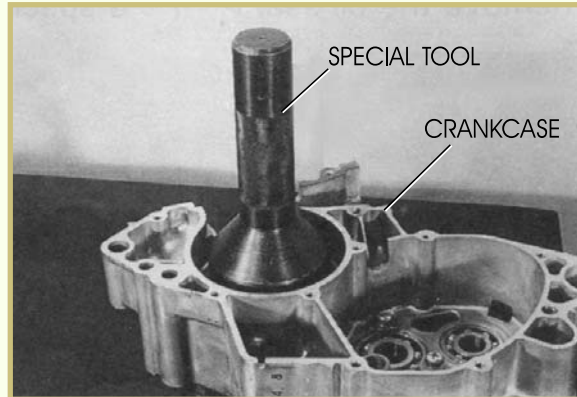

Inspecting the Clutch

The clutch is one of the most common two-stroke engine components to wear out or fail. Although lower-end engine disassembly isn't required to remove the clutch, the clutch must be removed to disassemble the lower end. Refer back to your study unit on *Clutches, Transmissions, and Drives* for the procedure to inspect the clutch. A thorough clutch inspection should include the following checks and measurements:

- Length of springs
- Thickness of friction and steel plates
- Warpage of clutch plates

- Smoothness of clutch basket and clutch center grooves
- Wear of clutch basket bearing or bushing
- Wear or cracks in clutch hub and primary driven-gear assembly

Inspecting and Measuring the Multipiece Crankshaft

Multipiece crankshafts are normally rebuildable. The crankshaft connecting-rod lower bearings are usually of the roller-type and are replaced as one unit. The unit consists of rollers, cage, and crank pin as illustrated in [Figure 9](#). Many times the connecting rod is also part of this replacement unit.

FIGURE 9—This illustration shows the components of a multipiece tow-stroke crankshaft.

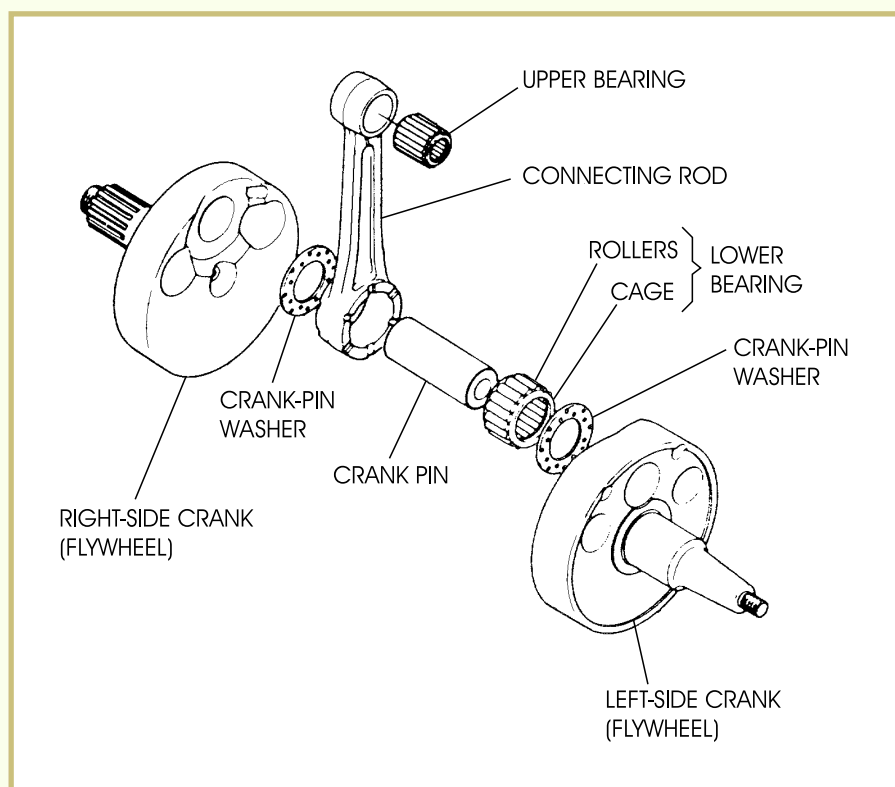

Replacement of the connecting-rod lower-bearing unit requires separation of the flywheels. Before separating the flywheels, measure their overall width at a point on each side of the crank pin, as illustrated in [Figure 10](#). Use a micrometer for this measurement. Careful measurement is necessary to ensure the correct replacement of the spacers used to align the crankshaft in the crankcase. The flywheels must be exactly the same dimensions when reassembled as when they were disassembled (as per manufacturer's specifications).

FIGURE 10—Measure the overall width of the flywheels at this point before disassembly.

(Courtesy of American Suzuki Corporation)

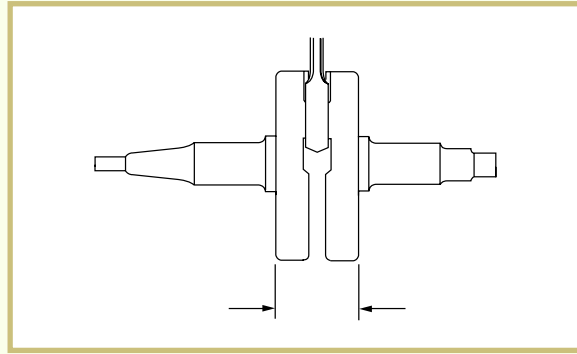

To separate the crankshaft flywheels, it's best to use a hydraulic press and special tools which consist of strong steel inserts. The inserts are placed between the flywheels and hold one of them securely in position. Pressure is then applied to the crank pin to force it out of the securely held flywheel. After the rod and bearings are removed, the crank pin is pressed out of the other flywheel from the outside, toward the opposite flywheel.

To replace a crank pin, carefully align it so that it can be pressed into one of the flywheels. Make sure it fits squarely before you attempt to press it in. Lubricate the rod and bearings and install them onto the crank pin. Also be sure to replace the connecting-rod spacers (crank-pin washers) before pressing the flywheels together. Align the other flywheel and press it onto the other end of the crank pin.

A final alignment of the flywheels is necessary to ensure that the axles will run absolutely true in the axle bearings. The center of each flywheel axle must remain perpendicular to the center of the connecting rod at all times. Alignment requires the use of a special tool called a crankshaft alignment jig (Figure 11). The crankshaft is placed in the jig and rotated. Dial indicators are positioned against the crankshaft axle surfaces. Rotating the crankshaft shows any misalignment of the crankshaft halves on the dial indicators and is known as *crankshaft run-out*. Run-out is the total dial reading and must be within the manufacturer's specifications that are given in the appropriate service manual. Excessive crankshaft run-out is often responsible for abnormal engine vibration and shortens the life of the two-stroke engine if not corrected.

Figure 12 shows correct and incorrect crankshaft alignment. If the alignment check using the jig indicates that the crankshaft must be aligned, one or both crank halves will need to be moved so that the crankshaft is in alignment. If the crankshaft must be realigned, the higher of the lopsided flywheels should be lightly tapped with a brass mallet. Brace the lower flywheel on a firm surface as you tap the higher wheel to align the shafts. Note: Be sure to check whether the engine you're working on contains soft shell cranks. These soft shell cranks should never be tapped to true to crank wheels. Doing so dents the shell and ruins the crankshaft.

FIGURE 11—Checking Crankshaft Run-Out.

(Copyright by American Honda Motor Co. Inc. and reprinted with permission)

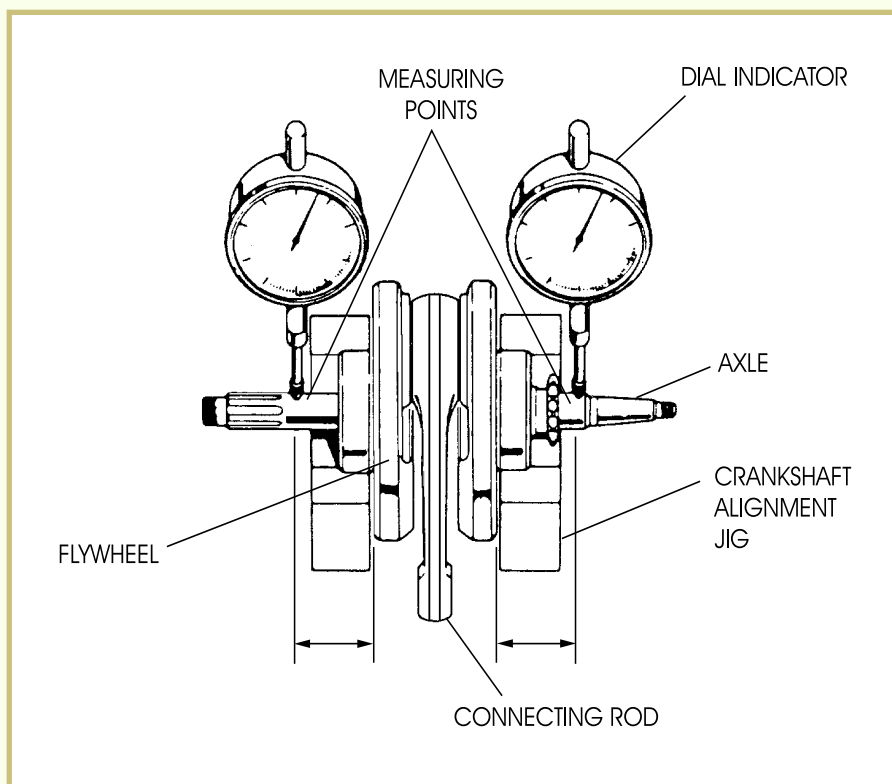
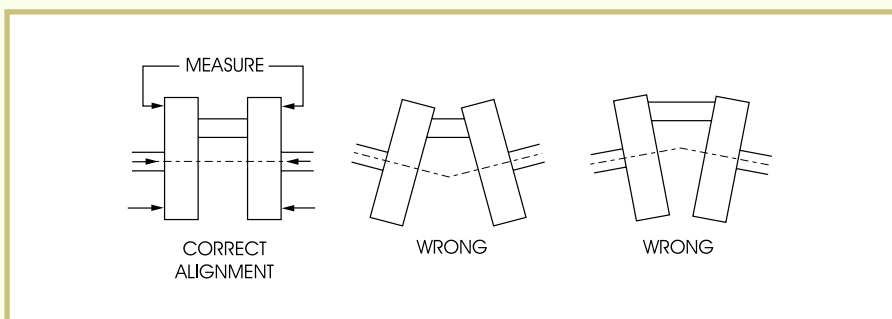

FIGURE 12—This illustration shows an exaggerated view of correctly and incorrectly aligned crankshafts.



When aligning a crankshaft, remember these points:

- Always use eye protection and gloves.
- Use light taps.
- Don't hit over the crank pin hole in the flywheel.

Check the alignment in the crankshaft alignment jig with each adjustment until the dial indicators show that the axles are in proper alignment. Cranks must be true to within .001" of total runout.

Inspecting the Transmission

When you opened the crankcase, you removed the transmission and set it aside. Now we'll disassemble the transmission, inspect the transmission gears and other components, and then reassemble the transmission and return it to the crankcase.

Disassembling the Transmission

When you remove the gears and other parts from the transmission shaft, it's a good idea to slip them onto a wire or long screwdriver to keep from losing them and to keep them in the proper order for replacement (Figure 13). Don't expand the retaining rings any more than necessary for removal. To remove a retaining ring, expand it and pull it off using the gear behind it. It's a good idea to always replace any retaining rings that are removed because they can be weakened if spread too far out during removal. To remove the transmission bearings, it may be necessary to use a bearing puller as pictured in Figure 14.

FIGURE 13—Install the transmission parts on a long screwdriver or piece of wire as you remove them to ease the assembly process. (Copyright by American Honda Motor Co. Inc. and reprinted with permission)

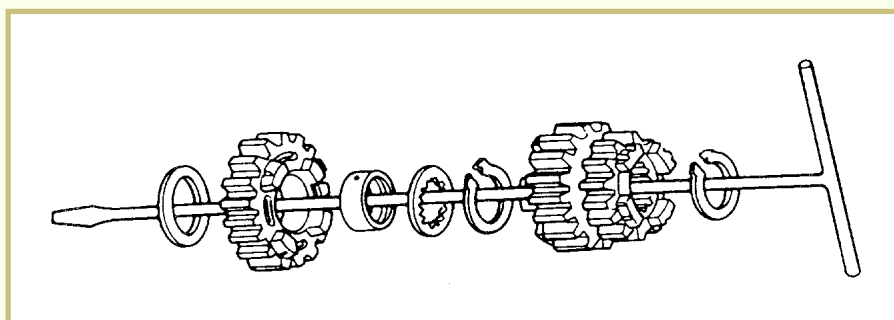
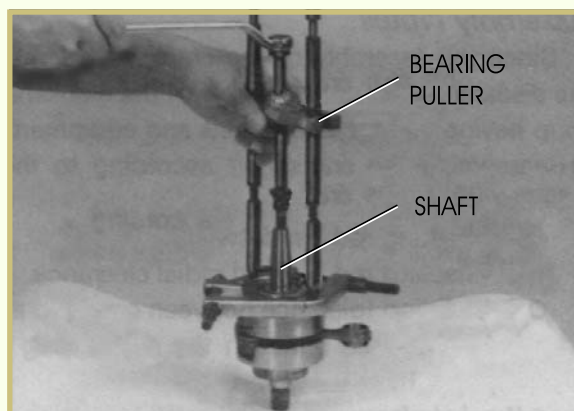

FIGURE 14—Some shafts will require the use of a bearing puller to remove bearings with a tight interference fit. The puller pushes against the end of the shaft to remove the bearing.

(Courtesy Kawasaki Motor Corp., U.S.A.)



Inspecting the Transmission Components

When inspecting the transmission components, always carefully inspect each and every component, not just the components with obvious damage. For instance, if you find a burned shift fork, also check the gear and shift drum for damage as well.

Check the gears for damage or excessive wear. Also inspect the gear dogs or slots for wear or damage (Figure 15). Measure the inside diameter of the gear (unless it's a splined gear) using an inside micrometer. Check the measurement with the appropriate specification given in the service manual.

FIGURE 15—Check the gear dogs for damage and measure the inside diameter of all non-splined gears. (Copyright by American Honda Motor Co. Inc. and reprinted with permission)

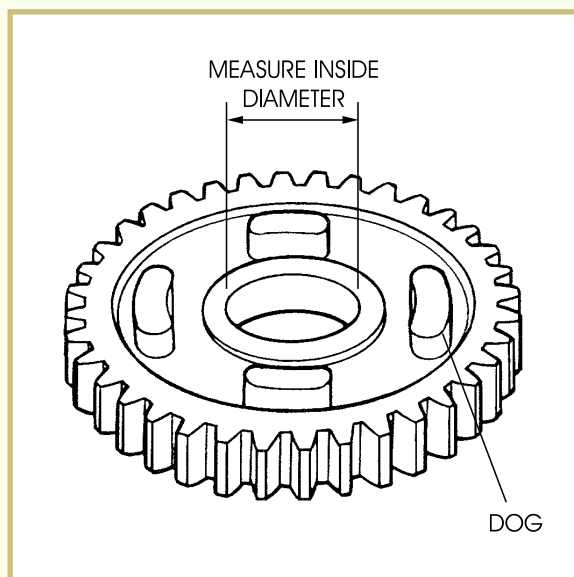

Inspect the gear bushings for wear or damage. Measure the inside and outside dimensions of the bushings to verify that they are within specifications.

Carefully inspect the main shaft and countershaft at their splined grooves. Check the shaft sliding surfaces for abnormal wear or damage. Measure the shafts for the proper dimensions as specified in the service manual (Figure 16).

The shift drum is a critical component of the transmission that should be inspected but is often overlooked. Many shifting problems may relate to a damaged shift drum. Check the shifting fork guide grooves for damage, such as a small chip or scoring (Figure 17). Also, inspect the shift-drum bearing to ensure that the drum can turn freely.

FIGURE 16—The transmission shafts should be measured at these locations. (Copyright by American Honda Motor Co. Inc. and reprinted with permission)

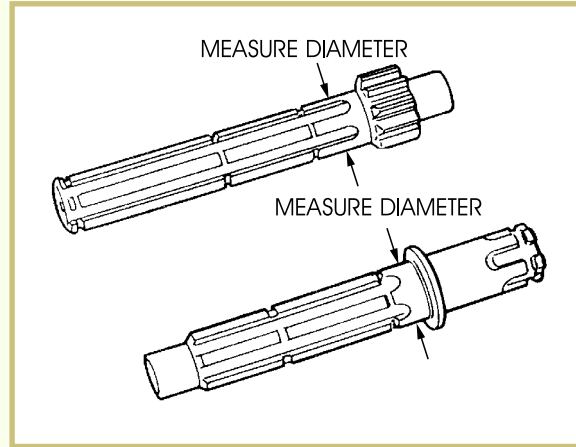
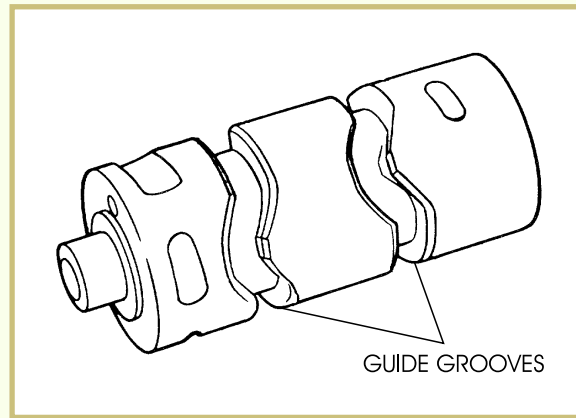
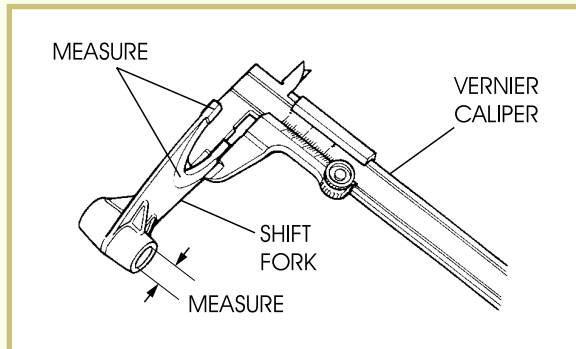

FIGURE 17—The shift guide grooves are often overlooked but should be inspected very closely for wear or damage. (Copyright by American Honda Motor Co. Inc. and reprinted with permission)



The next transmission component to be inspected is the shift fork. Although transmission problems aren't very common on most modern two-stroke motorcycles and ATVs, when a problem does occur, the shift fork is usually damaged also. Check the shift fork for deformation or abnormal wear. Use a Vernier caliper to measure the fork at the locations illustrated in [Figure 18](#) and compare the measurements to the factory specifications.

FIGURE 18—Use a Vernier caliper to measure the fork at the locations shown here. (Copyright by American Suzuki Motor Corporation)



A feeler gauge can also be placed in the shifting fork groove of the sliding gear to be measured for the proper clearance (Figure 19). The shift fork shaft must be checked for size and straightness—it should be measured at the areas where the shift forks slide.

FIGURE 19—Use a feeler gauge to check for proper clearance between the shift fork and the sliding gear. (Copyright by American Honda Motor Co. Inc. and reprinted with permission)

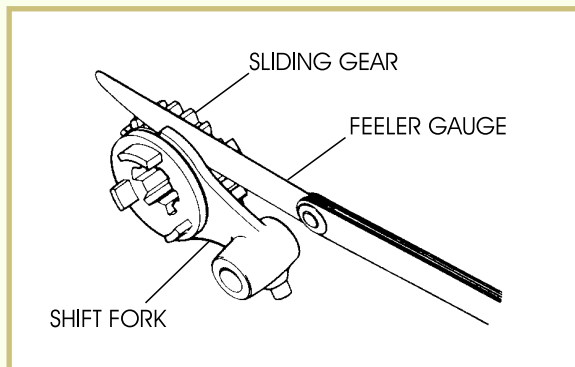

Assembling the Transmission

Before assembling the transmission, be sure that all parts are properly cleaned. Next, apply a molybdenum disulfide grease (molylube) to all sliding surfaces of each shaft before beginning the assembly process. This will ensure that there is adequate initial lubrication in the transmission.

Reassemble all of the transmission gears into the proper position on the appropriate shaft. All service manuals contain an exploded view of the transmission to assist with proper assembly of the gears, bushings, thrust washers, and retaining rings. Be sure to properly align the oil holes in the bushings to allow oil flow to the gears, as shown in Figure 20.

FIGURE 20—Make sure that all oil holes line up properly when you assemble the transmission. (Copyright by American Honda Motor Co. Inc. and reprinted with permission)

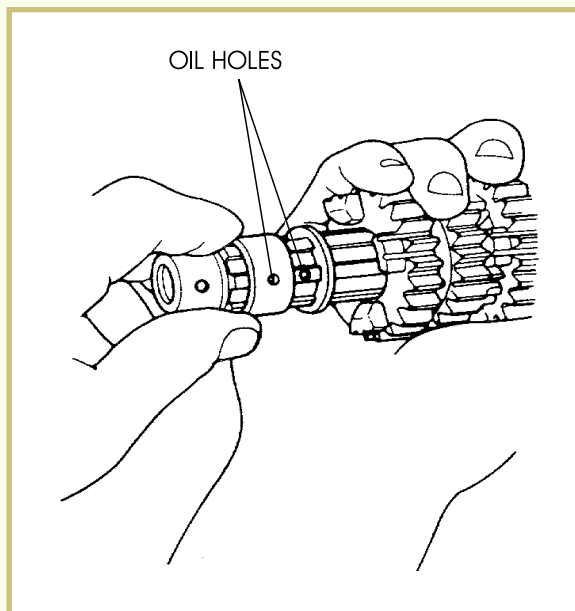

When you install the thrust washers, be sure that the chamfered side faces away from the thrust load side of the gear (Figure 21). Also, align the retaining ring with one of the grooves of the spline. If the retaining ring rotates easily in the groove, replace it. If the retaining ring doesn't seat properly and comes out, it can cause serious transmission failure. Some gears use lock washer systems that have a splined washer and a lock washer that are engaged, as illustrated in Figure 22.

FIGURE 21—The proper installation of a thrust washer and retaining ring is shown here.

(Copyright by American Honda Motor Co. Inc. and reprinted with permission)

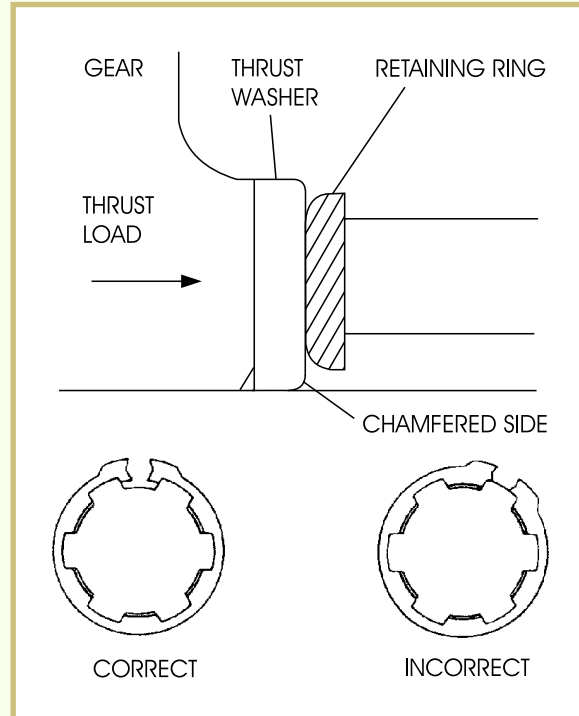
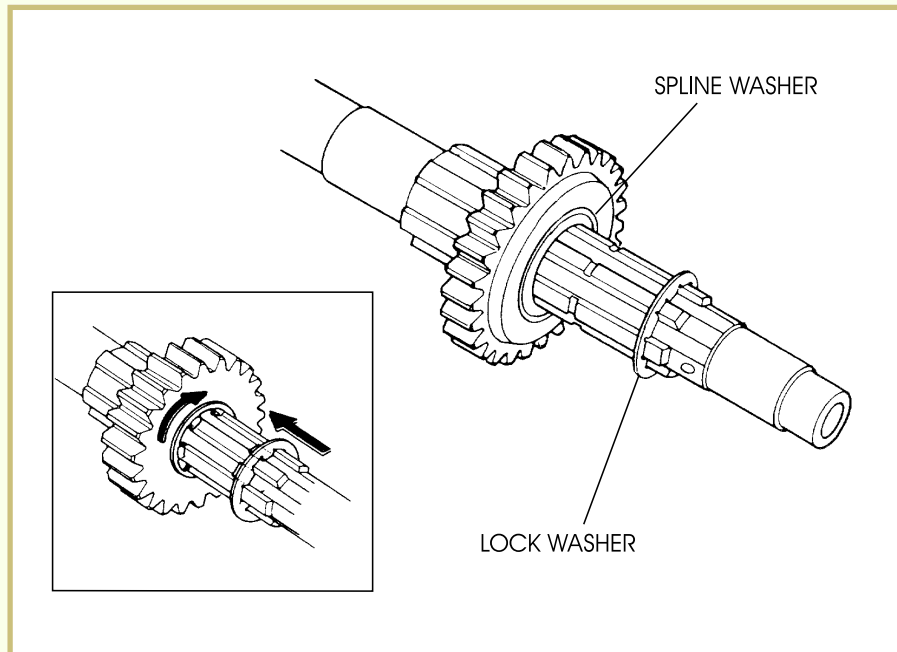

FIGURE 22—Some transmission shafts use lock washers.

(Copyright by American Honda Motor Co. Inc. and reprinted with permission)



Shift forks are marked to indicate their proper location. A fork marked with an “L” goes on the left side of the transmission. A shift fork marked with a “C” goes in the center, and a fork marked “R” goes on the right side.

After the transmission is properly assembled it's placed into the vertical crankcase as an assembly. You should then lubricate the transmission with engine oil while rotating the shafts, as illustrated in [Figure 23](#).

FIGURE 23—Rotate the shafts and lubricate all of the gears and shafts with engine oil.

(Copyright by American Honda Motor Co. Inc. and reprinted with permission)

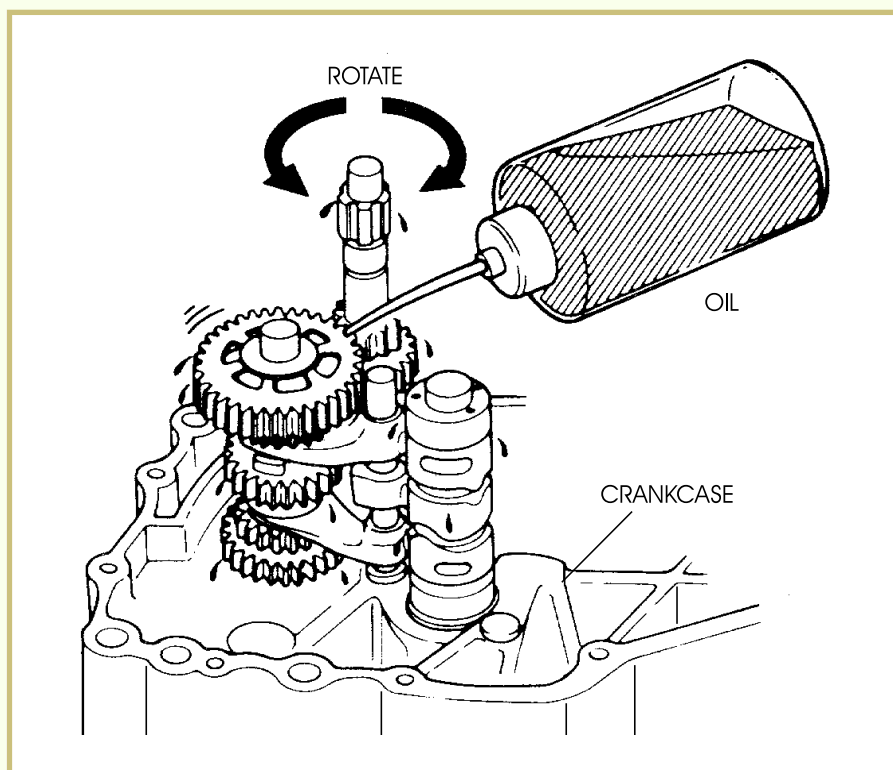

Transmission Power Flow and Symptoms

Now is a good time to review how transmissions operate and also to remember some of the problems that can occur in transmissions.

Motorcycles use constant-mesh transmissions, which means that all gears rotate at all times. Power is developed at the engine crankshaft and is transmitted through the clutch to the transmission main shaft. The main shaft transmits power through different sets of gears to the countershaft. Refer back to your study unit on *Clutches, Transmissions, and Drives* for a description of transmissions. Review the information about the gears and how they are moved to change the gear ratio between the main shaft and countershaft.

Some transmission problems can be diagnosed by the symptoms reported by the operator. Again, refer back to your study unit on *Clutches, Transmissions, and Drives* for a discussion of transmission symptoms and probable causes. The more common symptoms of transmission problems that you should be familiar with include

- Difficulty shifting
- Inability to shift gears
- Strange sounds
- Jumping out of gear

Road Test 3

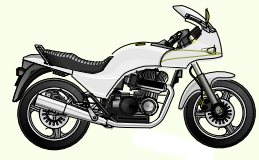

1. A _____ is used to disassemble the multipiece crankshaft.
2. The proper measuring tool to check for the thickness of the clutch friction plates is a _____.
3. If a shift fork is visually worn or damaged, what other parts, if any, should be inspected?

4. What does a shift fork with a marking of "C" indicate?

5. What can be used to verify that the transmission is properly reassembled, before you install it back into the crankcases?

6. A low growling sound when the two-stroke motorcycle or ATV is in gear and rolling will normally indicate what type of engine failure?

7. How are ball bearings held in place in the crankcase?

8. What should you use to help heat up the engine cases to help install a bearing?

Check your answers with those on page 45.

TWO-STROKE ENGINE REASSEMBLY PROCEDURES

Reassembly of the lower end of the engine is essentially done in the reverse order of disassembly. The reassembly procedure isn't difficult and a successful repair can be expected if care is used. Before reassembly, you should thoroughly clean all parts in a high-flashpoint cleaning solvent. When you're ready to begin the assembly process, be sure to stay organized and keep the different engine components separated to make your job more efficient.

Installing Crankcase Components and Closing the Crankcase

The crankshafts used in vertical two-stroke engine crankcases are usually the multipiece design. The crankshaft should be fully assembled with the connecting rod attached and ready for installation.

Note: The illustrations used in the following example procedure are courtesy of the American Suzuki Motor Corporation.

- 1 Install the crankshaft into the crankcase using any special installation tools required in the service guide.

Note: Never attempt to fit the crankshaft into the crankcase by hitting it with a hammer of any kind. Always use the special tools identified in the service guide; otherwise the crankshaft alignment may be affected.

- 2 Lightly coat all moving parts of the crankshaft with engine oil.

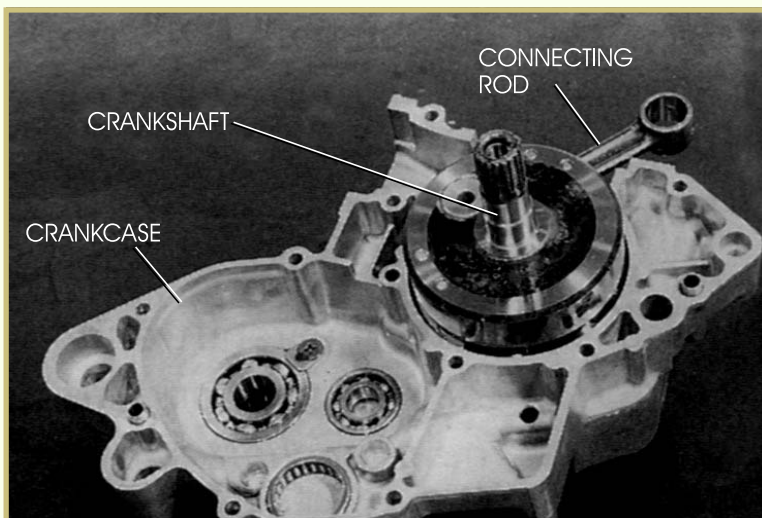

- 3 Install the transmission into the crankcase as a single unit. (In most cases, this includes the main shaft, countershaft, shift drum, and shift forks.)
- 4 Rotate the transmission shafts and lubricate all moving components with engine oil.
- 5 Ensure that the transmission is in the neutral position and that all shafts rotate freely.
- 6 Refer to the service guide to install other components in the lower end of the engine as necessary, such as
 - Gear shift linkages
 - Kick starter components
 - Primary-drive chains or gears
 - Idler gears
 - Electrical components

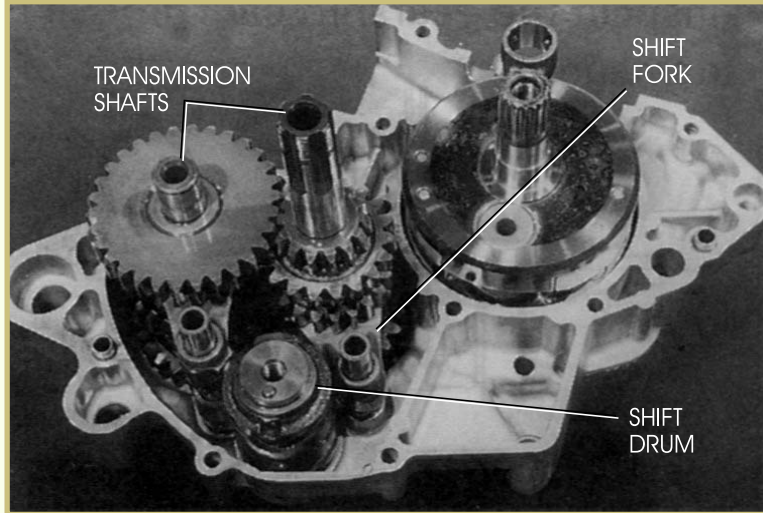

- 7 Ensure that all old gaskets or crankcase sealant has been properly removed from the crankcase halves. Apply new crankcase-sealing compound or gaskets as recommended by the manufacturer.
- 8 Install any dowels or alignment pins and O-rings into the crankcase half containing the transmission and crankshaft.
- 9 Check that all shafts rotate freely.

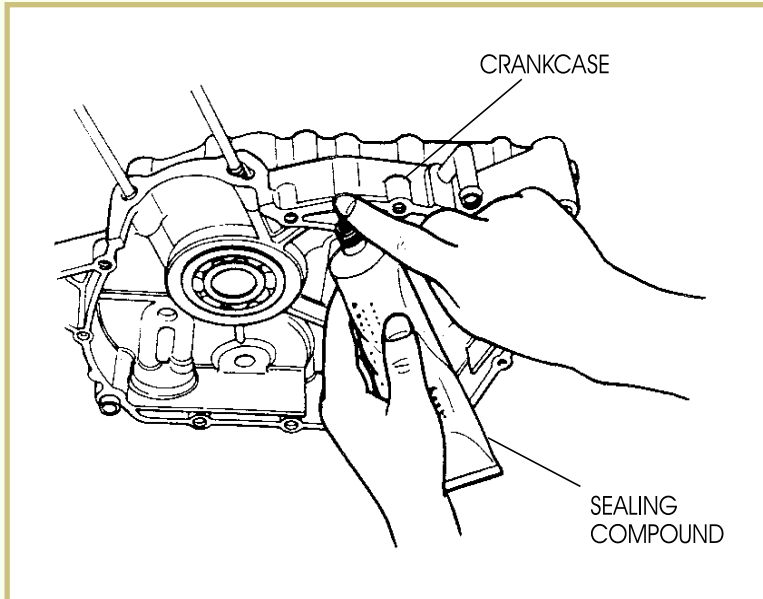

10 Use the dowels or alignment pins to align and install the other crankcase half on the crankcase half containing the transmission and crankshaft.

11 Install the fasteners that hold the crankcase halves together.

Note: Not all crankcase fasteners are the same length. Be sure each fastener is in its proper hole. If you insert a fastener that's too long into a hole, you can easily break the aluminum case. If you install a fastener that's too short, you can easily strip the threads.

12 Tighten the fasteners in the proper sequence and torque all fasteners as specified in the service guide.

13 Check that the shafts still rotate freely. If there is any abnormal resistance in a shaft, tap on the shaft using a plastic hammer. If there is still resistance, disassemble the crankcase to locate the problem. One of the most common causes is a misplaced spacer or thrust washer

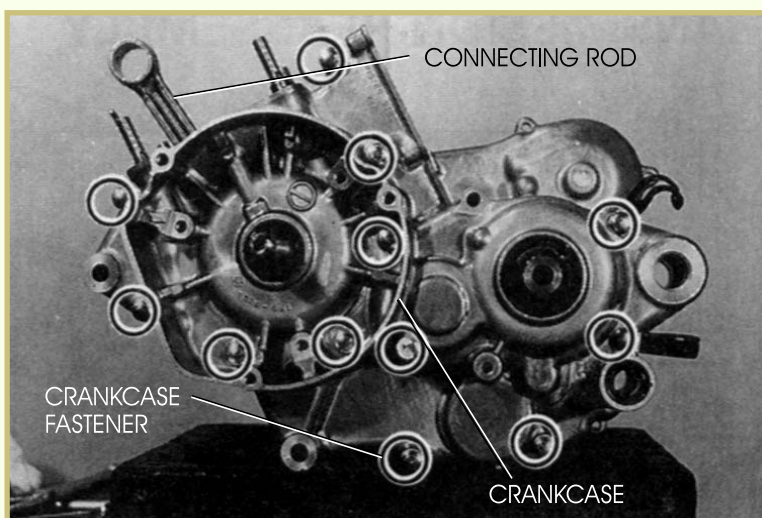

Installing the Clutch and External Components

After the crankcase is assembled, it's time to install the external components. We'll begin by installing the external shifting components. The gear positioning lever, neutral detent, and shift drum cam are usually assembled at this time.

Note: The illustrations used in the following example procedure are courtesy of the American Suzuki Motor Corporation.

- 1 Install the gear shift shaft. Be sure to correctly fit the shift shaft spring or the transmission won't shift properly.

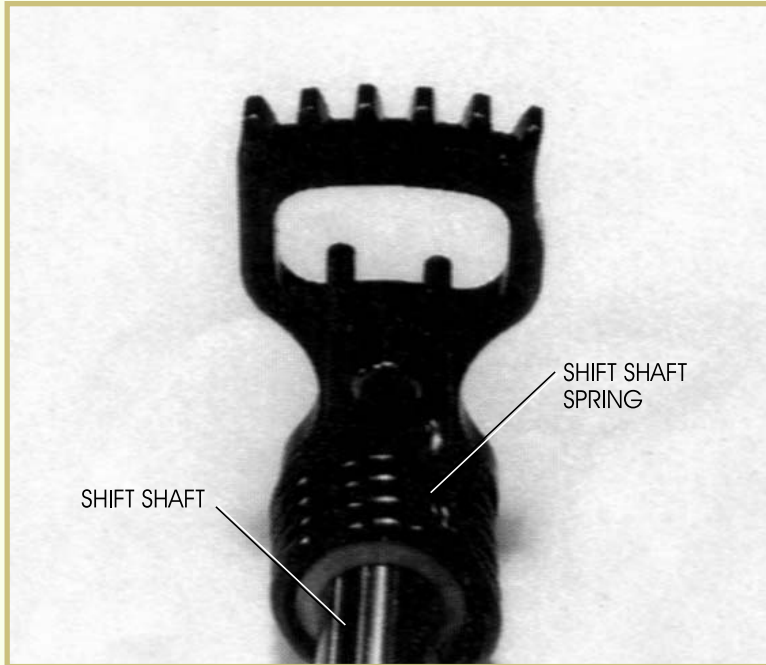

- 2 Install the shift shaft with the center teeth of the gear mated with the center teeth on the shift drum cam.

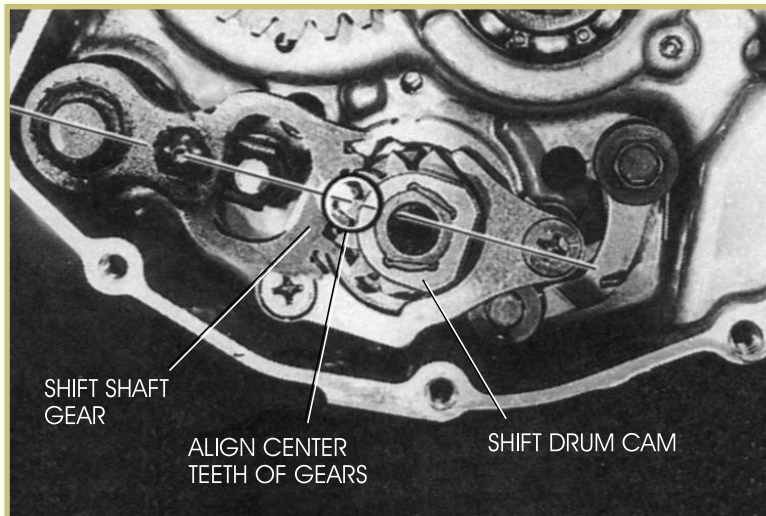

3 Install the oil pump assembly onto the crankcase. Fit the driven piece into the oil pump drive piece, before installing the pump.

4 Install the primary-drive gear. Ensure that the key is properly aligned with the gear key-way slot. Tighten the gear retaining fastener to the proper torque.

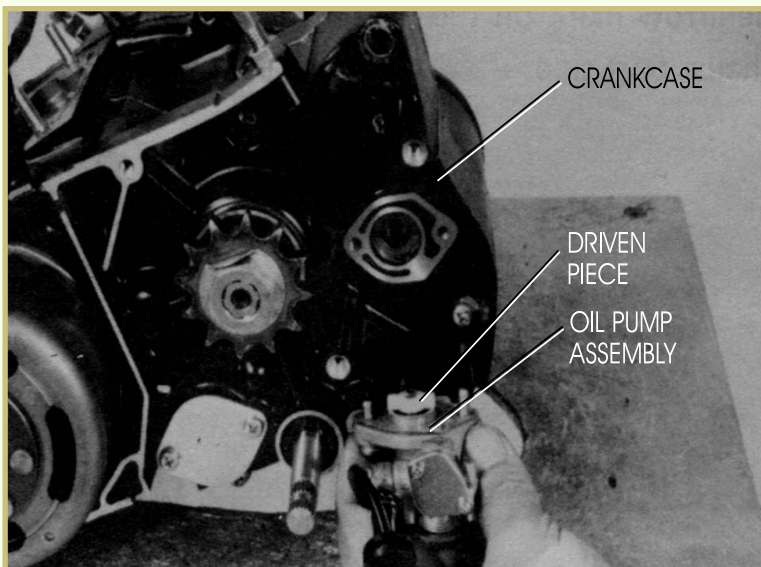

5 Check the kick-start mechanism components. Ensure that all components, including the catch mechanism, and spring, are in good condition.

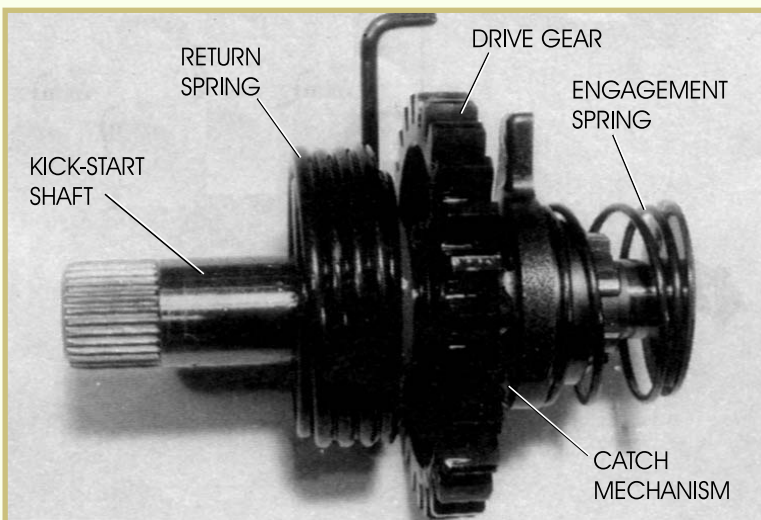

6 Install the kick-start mechanism (except for the kick-start lever) onto the crankcase. Be sure to hook the return spring. Make certain that all spacers are in their correct places. The kick starter won't operate properly if the spacers are not correctly installed.

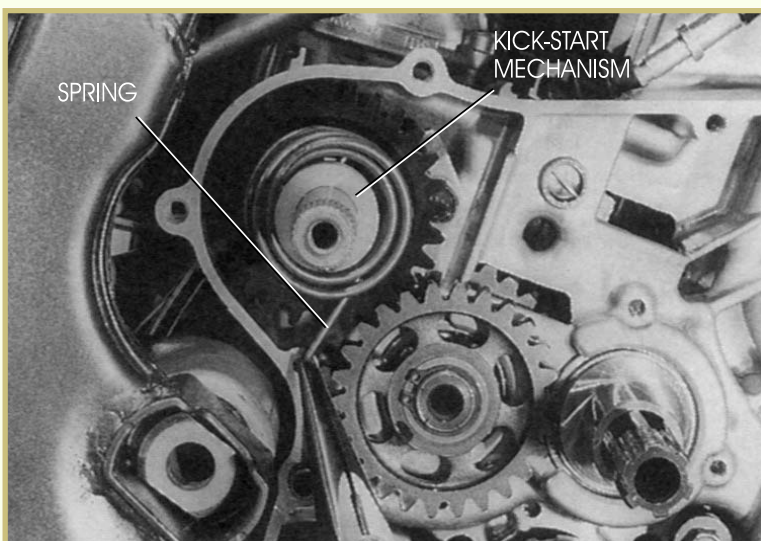

Note: It's good practice to install the cylinder assembly before installing the clutch. This prevents possible damage to the piston if the engine rotates when you tighten the clutch hub retaining nut.

- 7 Install the clutch outer and clutch center. Install the clutch hub retaining nut. Lock the nut by bending the tongue of the lock washer over a flat side of the nut.

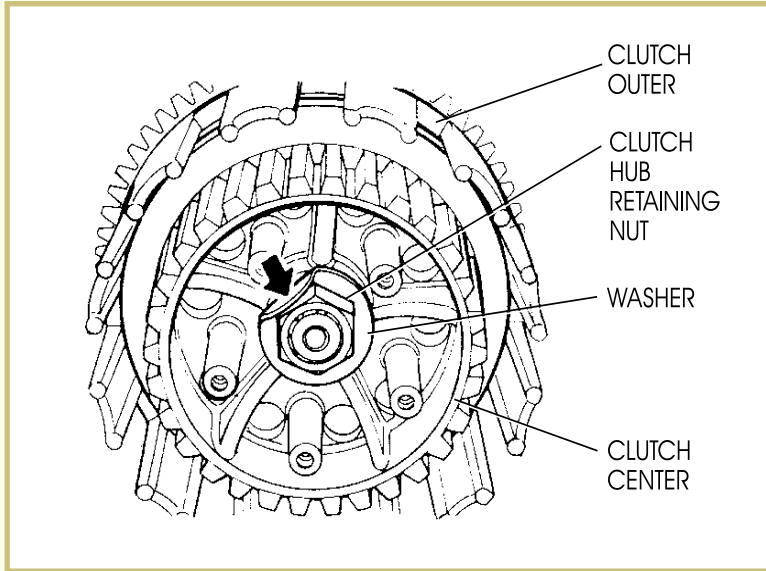

- 8 Insert the clutch friction and metal plates one at a time into the clutch assembly.

- 9 Install the clutch spring bolts in a diagonal sequence, as shown.

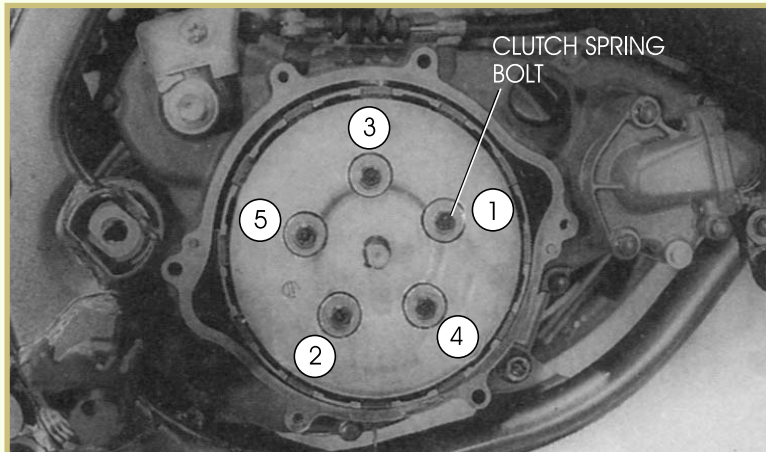

- 10 Replace the cover gasket and install the clutch cover.

- 11 Tighten the clutch cover fasteners.

- 12 Before installing the engine in the frame, make sure there are no leaks in any of the engine seals or gaskets. Even a small air leak can result in a seized engine.

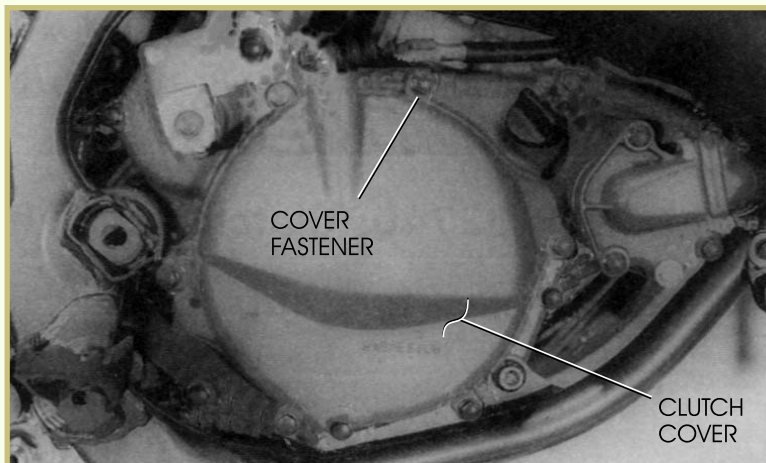

Installing the Magneto Rotor and Stator

When installing the magneto components, remember that most rotors have a line to mark the proper ignition timing. You'll learn more about motorcycle and ATV electrical systems, including ignition systems, in a later study unit.

Note: The illustrations used in the following example procedure are courtesy of the American Suzuki Motor Corporation.

- 1 Install the magneto stator into the crankcase assembly and secure it with the stator securing screws
- 2 Install the Woodruff key into the crankshaft and carefully install the rotor.

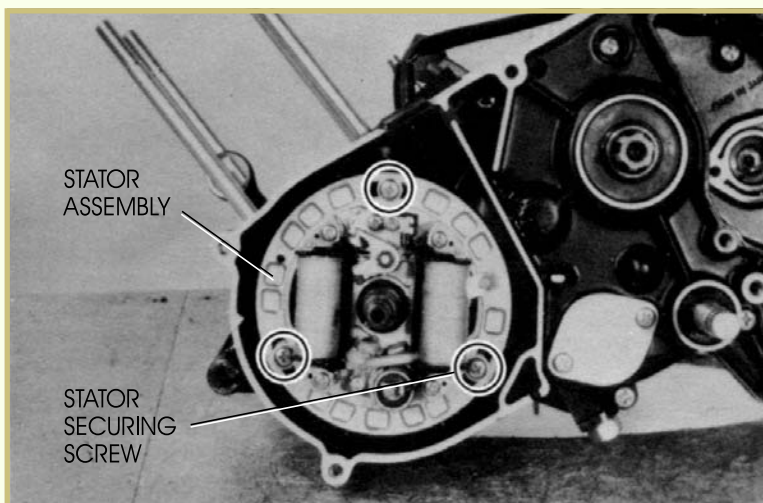

- 3 Using the special holding tool to prevent the rotor from turning, tighten the rotor fastener nut to the specified torque.
- 4 Install the rotor cover, starter motor, and starter motor gearing mechanism.

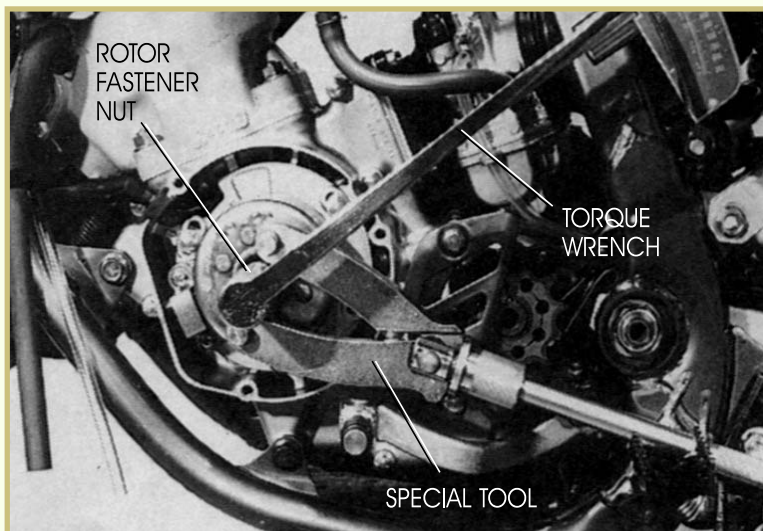

Bench Testing

After you've completed the assembly of the lower end of the engine, it's a good idea to verify that all components move freely and properly. You wouldn't want to discover that there is a problem after you've completely reassembled the engine and installed it into the chassis.

As a check to ensure that the lower-end assembly is operating satisfactorily, turn the crankshaft to make sure it moves freely. Shift the transmission into every gear to make sure that there are no apparent problems inside of the engine. When you're satisfied that all components have been assembled correctly, you're ready to reinstall the engine into the chassis.

Road Test 4



1. What is a common cause of a shaft not turning freely after the crankcase halves are bolted together?

2. *True or False?* The two-stroke engine crankshaft connecting rod is normally a single-piece design.
3. *True or False?* Two-stroke vertically split engine crankcases require a gasket or a sealer to ensure the case halves seal properly.
4. What should be installed before installing the clutch to prevent piston damage?

5. What is the purpose of a bench test following assembly of the lower end of the engine?

6. *True or False?* A hammer is used to tap the crankshaft into the crankcase.
7. After the crankcase fasteners have been properly tightened, and there's abnormal resistance in any shaft, how should you try to free the shafts before disassembling the crankcase?

8. *True or False?* All crankcase fasteners are the same length.
9. Before installing the crankcase halves together, what components should you check to verify that they move freely?

10. *True or False?* The crankshafts used on the motorcycle and ATV two-stroke engine are of the single-piece design.

Check your answers with those on page 45.

TWO-STROKE ENGINE INSTALLATION

Now that the engine has been reassembled and bench tested, it's ready to be installed into the chassis. As in the previous procedures that we've covered, you'll find that there's a pattern of steps that can be applied to all makes and models of motorcycles and ATVs. Use the following procedures to understand the general steps and their sequence, but always refer to the service guide when performing actual maintenance.

Installing the Engine into the Chassis

Before you begin to install the engine in the chassis, it's very important to clean and organize all of the chassis and engine parts. Clean the chassis thoroughly and remove all necessary hardware to make the installation job easier. It's best to have a clean and well-prepared "rolling chassis" before you begin. A rolling chassis is a motorcycle or ATV that's completely assembled except for the body work and engine.

Note: The illustrations used in the following example procedure are courtesy of the American Suzuki Motor Corporation.

Note: To install the engine into the chassis, it's advisable to get at least one other person to help you install the engine and align the mounting points. After the engine is positioned in the chassis, a jacking device may be useful to hold the engine in place while the mounting hardware is installed.

- 1 Position the engine in the chassis and align the mounting points on the engine and chassis. Install and tighten the mounting hardware. The service manual should contain an exploded view of the mounting hardware to help you correctly install all of the parts.
- 2 Install the gear shift linkage and footrest brackets that were removed to take the engine out of the chassis.
- 3 Reconnect the electrical connectors.

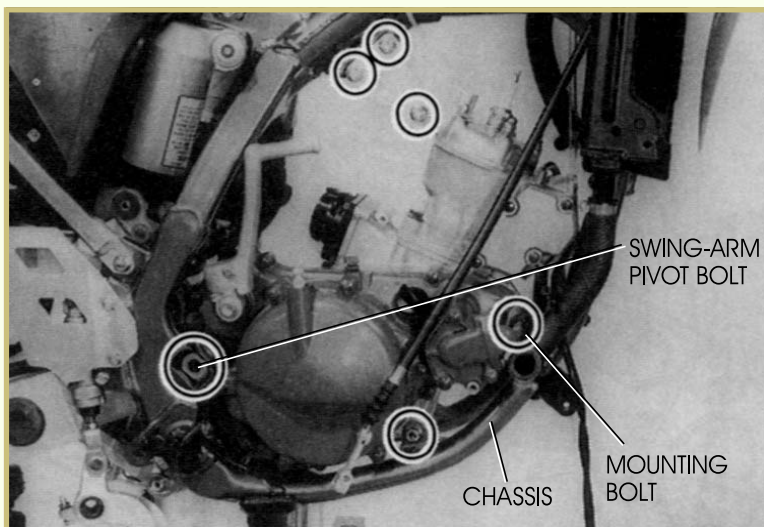

- 4 Install the engine sprocket.
- 5 Install the drive chain and secure the master link.

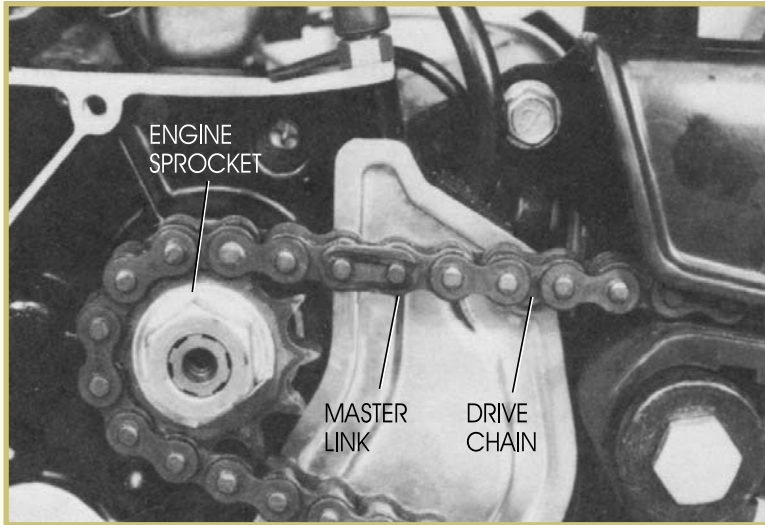

- 6 Install the exhaust system and secure it to the engine and chassis with the exhaust mounting hardware.

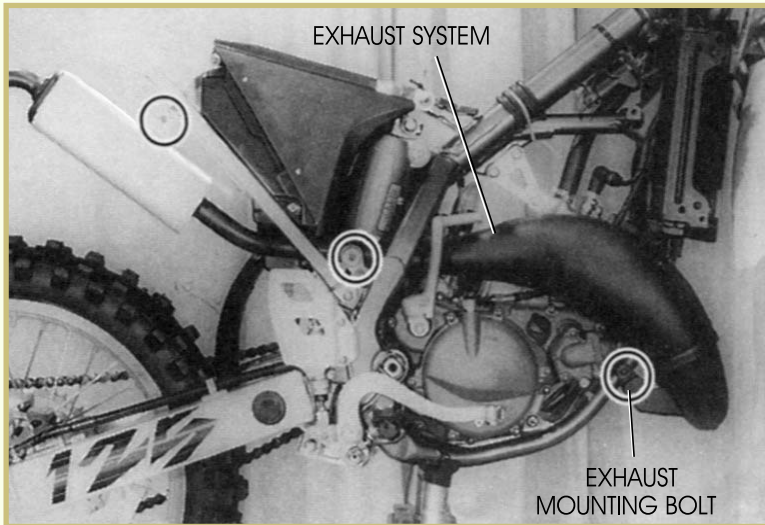

- 7 Install the radiator and coolant lines.
- 8 Install the carburetor and secure with mounting hardware. Install the air box and control cables.
- 9 Install the spark plug and spark plug lead.
- 10 Install the other electrical connections and components not previously connected or installed. Refer to the service manual for the proper order of assembly.

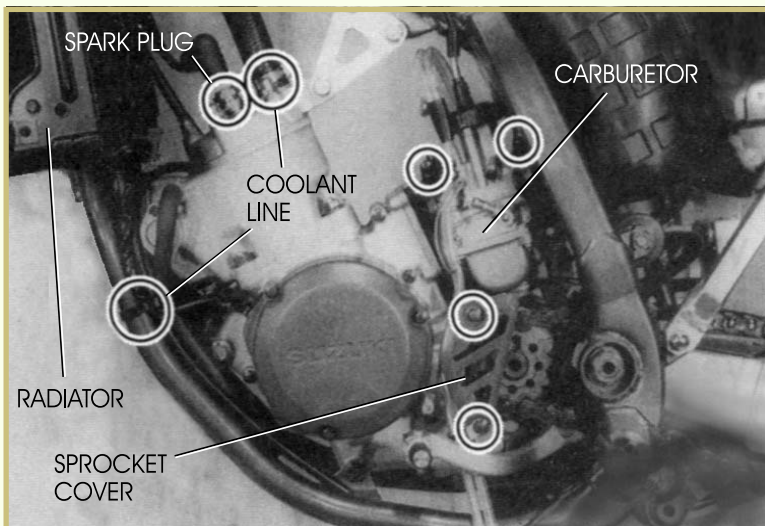

Installing Chassis and Body Components

You're now ready to install the remaining chassis and body components. This procedure will complete the reassembly process and you'll be ready to start the engine and test your work.

Note: The illustrations used in the following example procedure are courtesy of the American Suzuki Motor Corporation.

- 1 Install all body parts and hoses that were removed during disassembly, including the fuel tank and fuel hose connections.
- 2 Check all fasteners to verify that they are properly tightened.
- 3 Verify that all electrical components are properly installed.

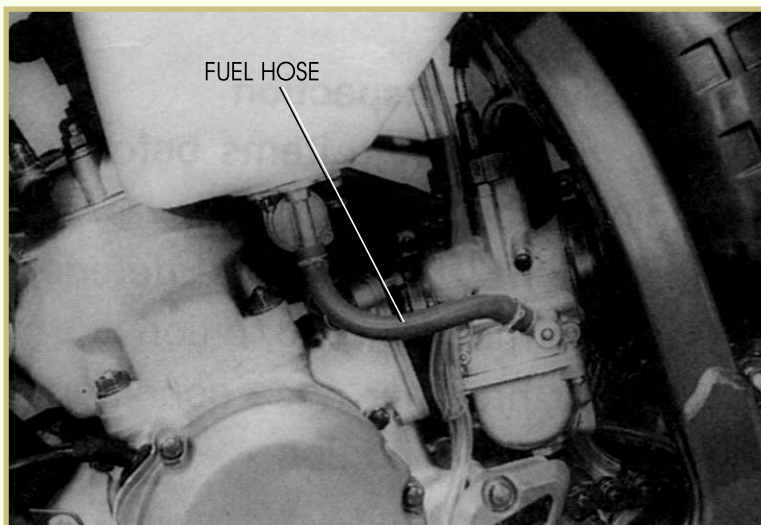

- 4 Remove the filler cap and add the appropriate amount of transmission oil to the engine. Install and tighten the filler cap.
- 5 If the engine is liquid cooled, fill the radiator and inspect for obvious leaks around hoses or connectors.
- 6 Check that the engine rotates properly by engaging the kick starter.
- 7 Turn on the fuel petcock and assure that fuel flows to the carburetor to fill the float bowl.

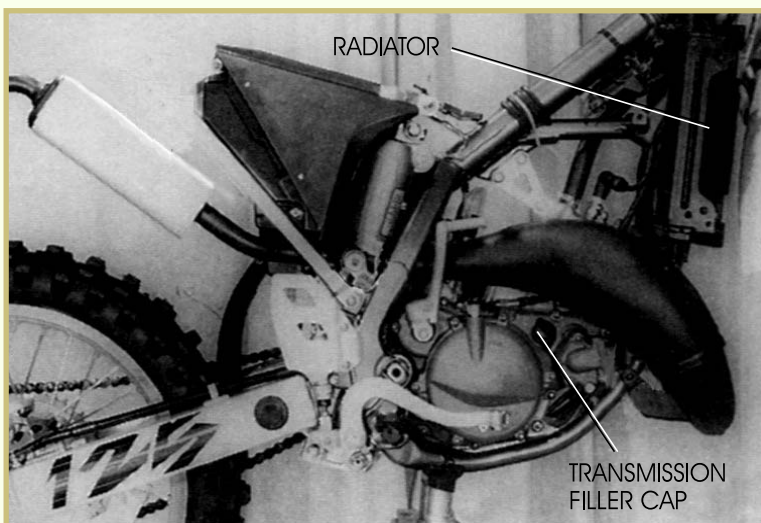

Starting the Engine

When you're certain that all components are in place, all fasteners have been properly tightened, and the fluids have been added, it's time to start the engine. The engine should start with 5–10 kicks of the kick starter. If the engine doesn't start, stop and verify that all connectors are attached and then try again.

Once started, let the engine idle or keep it running at as close to idle as you can. As the engine is warming up, check for any leaking fluids in and around the engine. Shut the engine off and allow it to cool to room temperature. Top-off the coolant on a liquid-cooled engine and verify that the oil is topped-off to its proper level.

Breaking-in the Engine

Most manufacturers recommend that a new or reconditioned engine be properly broken-in to make sure that all components are sealing well and mesh together properly. Even though you use the best-quality materials and original equipment, it's still necessary to break-in the engine before subjecting the engine to maximum stress. The future reliability, as well as the performance of the engine, depends on a proper break-in procedure. This includes extra care and restraint during the early life of the reconditioned engine.

Some general rules for engine break-in are as follows:

- For two-stroke off-road machines, such as the machines described in this study unit, keep the engine at less than one-half throttle for the first two hours of engine operation.
- For two-stroke street bikes, keep the engine operation at less than one-half throttle for the first 600 miles.
- After the time period or mileage has been reached, replace the engine oil and filter to remove any contamination from the break-in procedure.

After the engine has been operated for the suggested time period, the motorcycle or ATV can be subjected to the normal riding habits of the rider.

Road Test 5

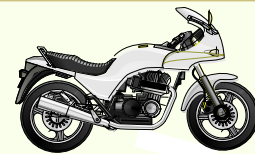

1. What can be placed under the engine to keep it steady while you install the mounting fasteners?

2. Why are reconditioned engines “broken in”?

3. What should you check for while the engine is warming up after rebuilding it?

4. What should you do just prior to starting the engine for the first time after reassembly?

5. What should you do before reinstalling the engine in the chassis?

6. How long should the engine be run at less than one-half throttle for proper break-in on a two-stroke, off-road, liquid-cooled motorcycle or ATV?

Check your answers with those on page 45.

Road Test Answers

1

1. Draining the fluids will prevent making a mess after the engine is removed.
2. True
3. clean
4. Leaking engine seals, worn crankshaft bearings, worn connecting-rod bearings, transmission problems
5. The radiator cap

2

1. Cylinder head and cylinder
2. The stator
3. False
4. False

3

1. hydraulic press
2. Vernier caliper
3. The gears associated with the fork and the shifting drum
4. It's the center shift fork.
5. An exploded view of the transmission
6. A bearing
7. Interference fit
8. A hot plate

4

1. A misplaced spacer or thrust washer
2. True
3. True
4. The cylinder
5. To make sure that the engine is correctly assembled and there are no problems before installing the engine into the chassis
6. False
7. Tap on the shafts with a plastic hammer
8. False
9. All shafts
10. False

5

1. A jacking device
2. To help seat all of the new components properly
3. Fluid leaks
4. Check to be sure that all components are in place, all fasteners have been properly tightened, and the fluids have been added
5. Clean and organize all of the chassis and engine parts
6. Two hours

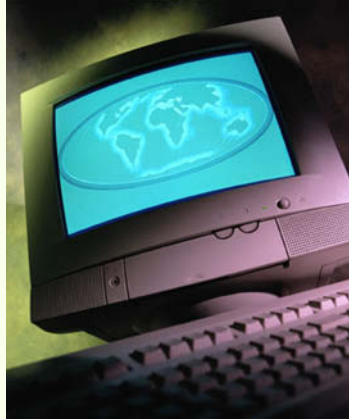

ONLINE EXAMINATION

For the online exam, you must use this

EXAMINATION NUMBER:

03301000

When you're confident that you've mastered the material in your studies, you can complete your examination online. Follow these instructions:

1. Write down the eight-digit examination number shown in the box above.
2. Click the **Back** button on your browser.
3. Click the **Take an Exam** button near the top of the screen.
4. Type in the eight-digit examination number.